



INSTALLATION INSTRUCTIONS

ENGINEERED HARDWOOD FLOORING

1. Installer's Responsibility
2. General Advice
3. Pre Installation
4. Installation
5. Post Installation
6. General Maintenance

1. Installer's Responsibility

Prior to installation it is the installer's responsibility to carry out a final inspection of the flooring to ensure the colour, grade, quality, manufacture and factory finish is acceptable and as expected. The installer must use reasonable selectivity and hold out or cut off pieces with deficiencies, whatever the cause. If the product is deemed not acceptable for any reason, you should not install the product and instead immediately contact your supplier. The product must also be checked with the end user to ensure the correct and expected product has been supplied. Once a product has been laid, and later discovered to be incorrect, or any boards deemed to be defective, no financial assistance can be given by Atkinson & Kirby, nor can the product be returned.

2. General Advice

To keep the wood in excellent condition it is imperative that the humidity level be controlled at all times, from delivery to laying the floor, and during the years that follow installation. The optimal humidity range for hardwood flooring is 45-60% and the temperature should be maintained at approximately 18°C.

Flooring should never be stored outdoors, on a cement floor, in a garage or in any damp conditions. Care should be taken to store the wood flat; packs should never be leant against a wall. All boards should be left in the packaging in the room where they are to be laid, with the same conditions that will be experienced once laid, until you are ready to lay the floor (at least 48 hours). In newly constructed buildings, the heating must have been operational for at least 10 days prior to installation.

Upon delivery, check the wood flooring moisture content with a moisture meter to establish a baseline for required acclimatisation.

A waste factor of 5-10% should be taken into account when calculating the amount of flooring needed. The expansion required for any hardwood flooring installation will vary depending the type of flooring, timber species and the size of the room. We recommend an expansion gap of at least 10-15mm for engineered floors around the perimeter of the room at doorways and at any other vertical surfaces. These gaps can be covered by mouldings which can be purchased separately from Atkinson & Kirby.

- Perimeter of the room - the gap can be covered by skirting board, if the skirting has remained in place the expansion gap should be covered with a scotia.
- Doorways - at doorways the floor should be broken with an expansion gap. The expansion gap should be covered with a twin or ramp moulding, which will allow the floor in individual rooms to expand and contract within their own areas. If floors are equal in height in both rooms then a twin moulding should be used. If floors have differing heights between rooms then a ramp mouldings should be used.
- Pipes, vents and other fixed objects - each can be unique, but the general rule is to measure very carefully before you cut the flooring and remember to leave a 12-18mm expansion gap between the object and the flooring. Cover the expansion gap with mouldings, vent covers or pipe rings when the floor is complete.
- Installation on stairs - flooring on stairs must be fully nailed to the stairs. Stair nosing mouldings should be installed using either screw type fasteners or nails.
- Contact with heat - in areas where the flooring comes into contact with a fireplace, stove, heating system or un-insulated hot air vents, a layer of asphalt or wax paper should be laid under the floor first. This will prevent excess drying out of the wood flooring. As always, leave an appropriate expansion gap between the floor and fireplace, stove etc.

For ease of installation some or all of the following tools are required:

- | | |
|-------------------------|-------------------------------|
| • Saw | • Professional knocking block |
| • Grip fill PVA glue | • Professional pull bar |
| • Hammer (500g minimum) | • Drill |
| • Tape measure | • Wedges |
| • Pencil | • “T” Square |

3. Pre Installation

The choice of installation method will depend on the specific circumstances and the requirements of the final floor. Before selecting an installation method, the floor must be assessed for the following criteria:

- Moisture content of the subfloor - moisture tests should be carried out using a hygrometer on all ground floor installation and on all new build upper floors where a screed has been used. Moisture readings above 65% relative humidity (RH) indicate a damp floor. If this is the case, a damp proof membrane (DPM) should be installed on the subfloor. If in doubt about the presence of excess moisture in the subfloor, it is recommend you use a suitable DPM (please refer to the DPM manufacturer’s guidelines for more details).
- Smooth subfloor - if the subfloor is not smooth enough to accommodate the wood flooring, apply a smoothing compound to level out the subfloor.
- Sound and strong substrate material - if the substrate is not strong enough to accommodate the flooring, screeding of the subfloor will need to be carried out.
- Requirements for improved acoustics - if there is a requirement then the floor should be fully glued down using an adhesive that specifically offers improved acoustic properties.
- Type of subfloor - engineered flooring is not suitable for installation on asphalt subfloors.

Before beginning installation, spread out short and long lengths of floor boards equally over the area where the floor is to be installed and work out of several packs at a time to ensure an even colour and shade distribution over the whole floor.

4. Installation

Glue Down Method

Establish a starting point

Align the first row of planks to be sure that you have a straight line from one side of the room to the other. Draw a chalk line at the desired distance from the wall to help align the planks. The end joints of the flooring in the next row should always be staggered (minimum of 150mm) to achieve the best appearance in the finished floor. Align the first piece of flooring on the chalk line with the groove side and end facing the starting wall.

Full stick down method - using a rigid adhesive: For use on sound, strong subfloors which are permeable.

Apply the adhesive using a V notched trowel with a minimum notch depth of 4.7mm and width of 3mm. Flooring must be adjusted with a block and mallet immediately after laying.

Full stick down method - using a flexible adhesive: For use on virtually all subfloors

Apply the adhesive using a V notched trowel with a minimum notch depth of 6mm and width of 3mm. Flooring must be adjusted with a block and mallet immediately after laying.

For glue down installation over underfloor heating, please see separate section on “Underfloor heating installation”.

Batten bonding stick down method - using flexible adhesive: not suitable for installation over underfloor heating.

The adhesive should be applied by cartridge or sausage using a nozzle cut to ensure a 10mm high by 8mm wide cordon. Beads should be laid at 100-250mm intervals (depending on the width of the board).

Floating Method

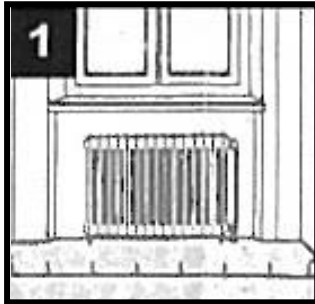

Fig 1.
Ensure the subfloor is sound, level and free of debris. Cover the floor with an appropriate underlay. If installing over existing floorboards ensure they are fixed solidly.

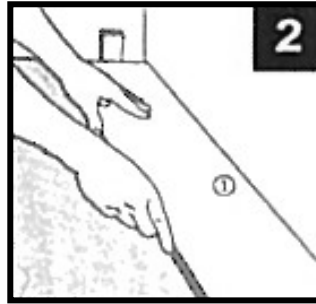

Fig 2.
Layout the first board with the groove towards the wall ensuring an expansion gap of min. 10mm is left. Complete the first line of boards, but do not glue at this stage.

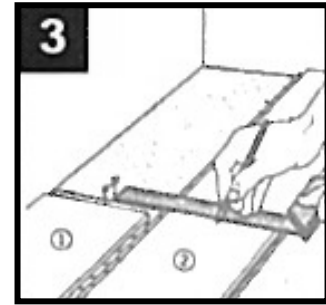

Fig 3.
Turn over the last board of the first row with its tongue facing the tongue of the preceding board. Mark a cutting line on the back of the boards and cut to length. Fit the board to the end of the row without glue.

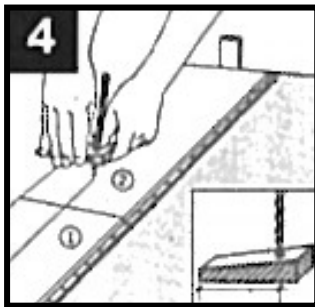

Fig 4.
It is important that the boards follow the line of the wall. If the wall is not square, make a line parallel to the wall and cut the board accordingly.

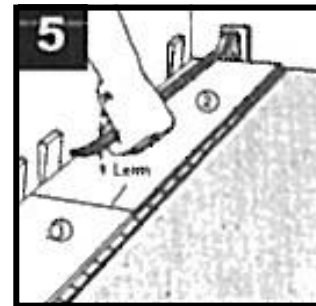

Fig 5.
Lay out the boards along the wall (groove facing the wall) and insert wedges. P.V.A. adhesive should now be applied to the groove and header joints. The final board will need to be fitted using a pull bar.

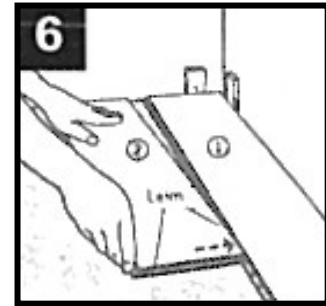

Fig 6.
Providing the off cut from the first row is at least 300mm in length, this should now be used to start the second row. You should stagger the header joints by at least 400mm.

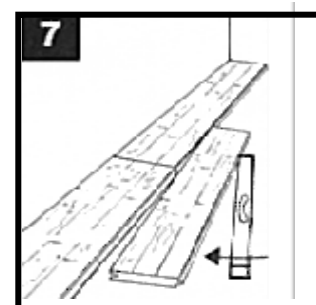

Fig 7.
A continuous bead of P.V.A. adhesive should be applied to the upper edge of the groove on the board, the header joint should also be glued. Join the boards together by placing the tongue into the groove of the previous board, ensuring the header joint is closed. The boards should now be knocked home with the use of a 600mm knocking block. The knocking block should be used on the tongue in a flicking action. Hold one end of the block against the board, with the other end at an angle of approximately 45° away from the board. Flick the block against the tongue with a sharp action, this will knock the board up. Continue down the full length of the board, using a hammer on the knocking block if necessary. Continue across the floor, making sure to clean any P.V.A adhesive off the face of the floor with a damp cloth.

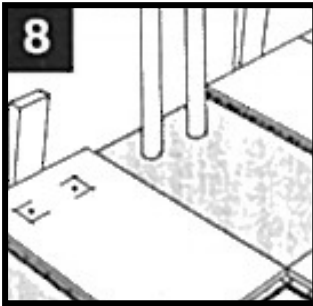

Fig 8.
Wherever there is a central heating pipe or anything protruding from the floor, place a board in the next row, take exact measurements and mark the sections to be cut of the back of the board.

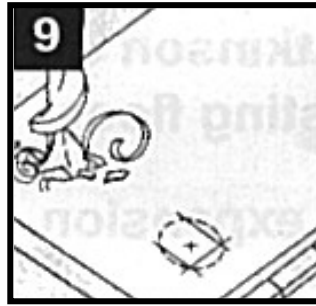

Fig 9.
Drill or cut the area needed, remembering to leave an expansion gap.



Fig 10.
Cut the board at an angle of 45°.

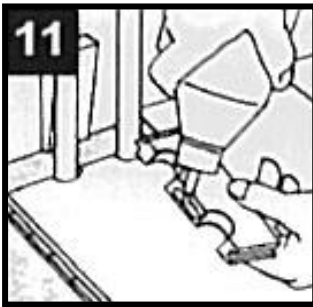

Fig 11.
Apply P.V.A. adhesive to the edges of the cut board and fit into place. Care should be taken to leave an expansion gap between the board and the wall.

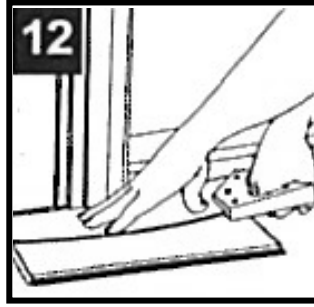

Fig 12.
Door frames and other wooden elements should be sawn off to allow the board to slide underneath.

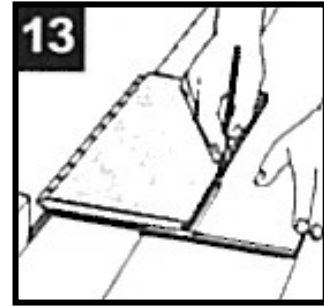

Fig 13.
For the final row, lay the board over the last but one line of boards (tongue facing the wall). Place another board face down over the board to be cut, remembering to leave the expansion gap, and mark the back of the board.

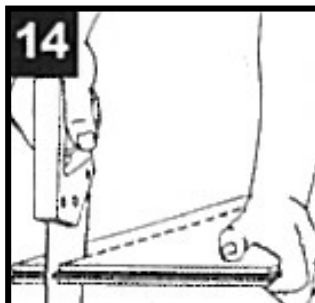

Fig 14.
Cut the board to size with a jigsaw or handsaw.

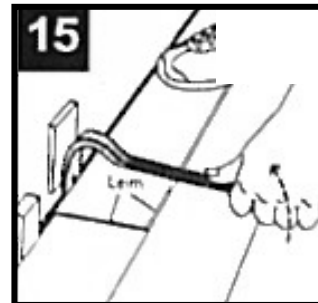

Fig 15.
Place the last line of boards in place and knock up using a professional pull bar.

Secret Nailing Method

Establish a starting point

Before beginning the installation, spread out long and short lengths equally over the area where the floor is to be installed and work out of several packs at a time to ensure an even distribution of colour and shade over the whole floor.

Remember: flooring is to be installed at right angles to the existing floorboards and if possible, in the longest dimension of the room.

Align the first row of planks to be sure that you have a straight line from one side of the room to the other. Draw a chalk line at the desired distance from the wall to help align the planks. The end joints of the next row of flooring should always be staggered (minimum of 400mm) to achieve the best appearance in the finished floor.

Installing the floor

Align the first piece on the chalk line with the groove side facing the starting wall. Pre drill holes and drive 7D or 8D finish nails or screw type flooring nails into the face of the board every 200-250mm, approximately 10-15mm from the edge closest to the starting wall. The nails should be within 50-75mm from the end of the board and in the darker grain of the wood to help conceal them.

Edge nail the plank by driving the same type nails at a 45° degree angle through the tongue of the first piece, spacing the nails every 200-250mm and within 50-75mm from the ends. This process should be repeated for each piece in the entire first row.

Upon completion of the first row, go back and sink the face nails with a nail punch. If it appears that the holes will not be covered by the wall base or quarter round trim, fill the holes with hardwood flooring putty that blends with your floor.

Begin installing the second row by repeating the edge nailing, but do not face nail as with the first row.

Note: typically the first few rows must be edge nailed by hand due to vertical wall obstruction. However, when clearance allows, an edge nailing machine, which drives 50mm fasteners with an appropriate mallet, can be used to simplify and speed up the process.

Install each succeeding row of planks by edge nailing and tongue side every 200-250mm to within 50-75mm from the board end. Be attentive to staggering the ends of the boards at least 400mm in adjacent rows to avoid the clustering of end joints. Any short boards should be locked in either side by longer boards ensuring that at least one end is nailed to the joist.

Upon reaching the last row to be installed, the planks should be ripped to allow 10-15mm expansion gaps. The last row must be fastened by face nailing approximately 12-18mm from the back edge of the board every 200-250mm. The same process of counter sinking the face nails and applying hardwood putty should be repeated.

Click Profile Installation

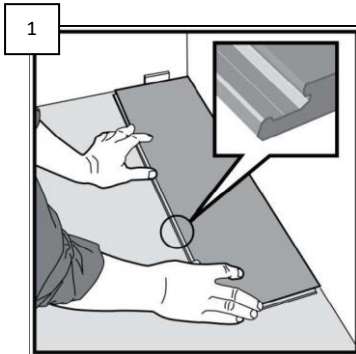

Fig 1. First row
Leave a min. 10mm expansion gap and begin in one corner, working from left to right with the tongue sides of the boards towards the wall.

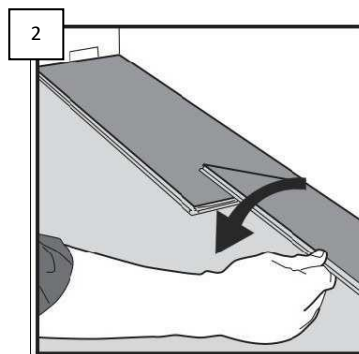

Fig 2.
Place the second floorboard at an angle to the end of the first row.

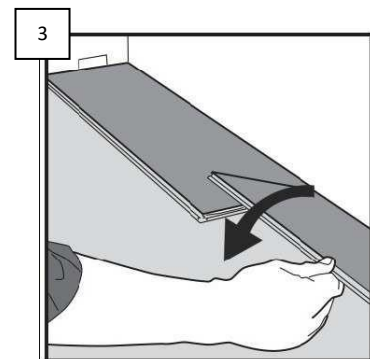

Fig 3.
Fold the panel down in a single movement, making sure the panels are tight against each other. Press down firmly or knock slightly at the end you have just installed.

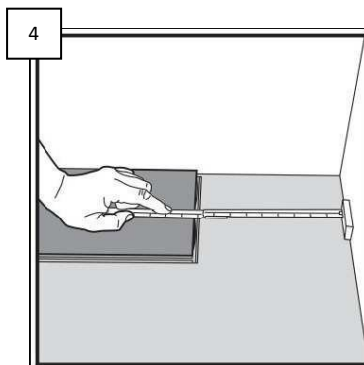

Fig 4.
Put a min. 10mm expansion gap at the wall and measure the length needed for the last plank.

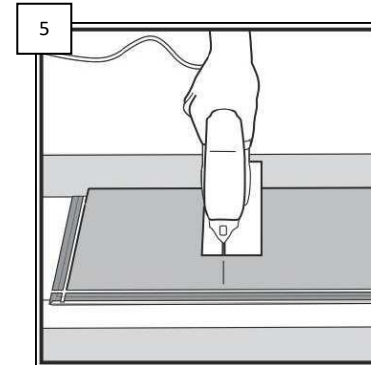

Fig 5.
Cut the plank to the required length with a jigsaw or handsaw.

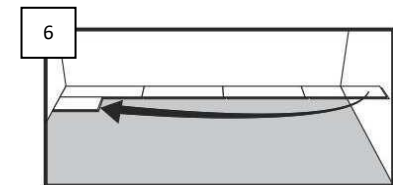

Fig 6.
Begin the second row with the piece left over from cutting the previous board.

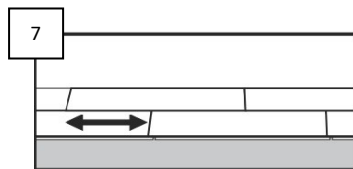

Fig 7.
Ensure header joints are no less than 400mm apart.

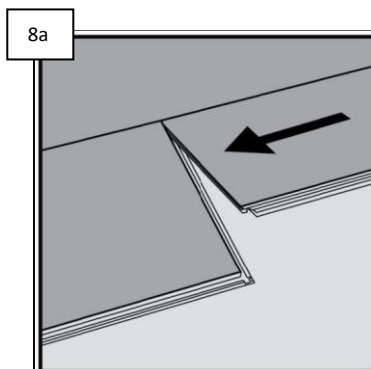

Fig 8a.
Place the second floorboard at an angle to the end of the first row.

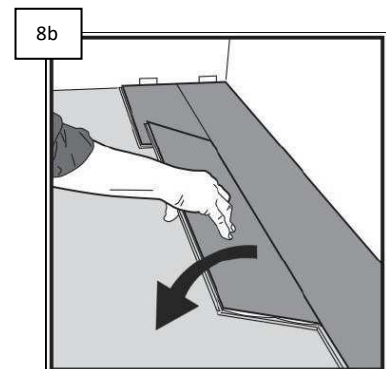

Fig 8b
Fold the panel down in a single movement, making sure the panels are tight against each other. Press down firmly or knock slightly at the end you have just installed.

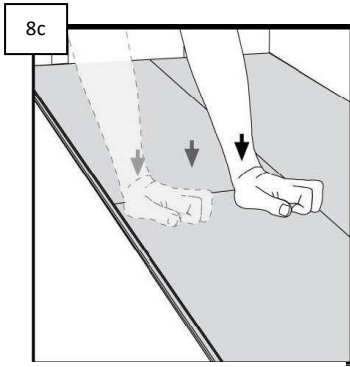

Fig 8c
Press or knock slightly along the short end of the installed panel.

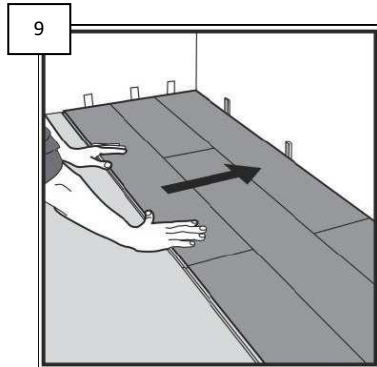

Fig 9
After 2 to 3 rows adjust the distances to the front or back wall by 10mm.

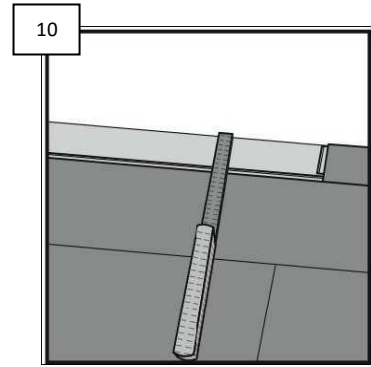

Fig 10
When it comes to the last row, leave a 10mm expansion gap and make sure the pieces installed are a minimum width of 50mm.

Disassembling

Click profile flooring can be easily disassembled and reinstalled during installation, which is particularly helpful when laying at doors or areas with obstructions.

The instructions below explain how to easily disassemble the click flooring as to not damage the locking system:

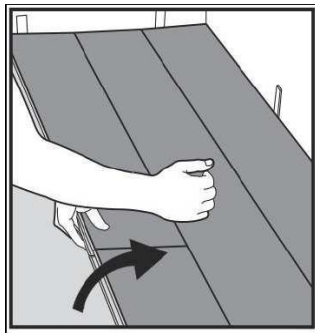

Fig 11
Separate the whole row by carefully lifting it up and gently knocking just above the joint. Lift up and release the whole long side of the board



Fig 12
Disassemble the panels on the short side by sliding apart horizontally.
NB Do not lift the short sides up.

Underfloor heating installation

- Atkinson & Kirby can only recommend hardwood flooring be installed over water based underfloor heating systems.
- The maximum temperature at the surface of the floor should be 27°C.
- To ensure this maximum temperature is adhered to, we recommend the use of an underfloor heating system that is controlled by floor sensors that allows for a gradual increase in temperature.
- Underfloor heating must be properly commissioned with correct heat up and heat down carried out.
- More information regarding underfloor heating heat up is contained in BS8201.

5. Post Installation

- Heating systems may have to be utilised throughout the year to maintain the correct humidity level.
- The installation of a humidifier or air exchange system can prove indispensable in controlling humidity.
- Wood is a natural, living material that must be cared for correctly for its lifetime. As such, a proper maintenance programme should always be carried on your hardwood floors.
- Barrier matting should be placed at all exterior doorways.
- Remove any dirt/grit left on the floor following installation to prevent scratches or damage to the floor.

6. General Maintenance

Routine maintenance and damage prevention is key to lifelong service and beauty from your hardwood floor.

Please ensure you follow our comprehensive maintenance guidelines for the relevant finish you have chosen for your floor. These can be downloaded from www.akirby.co.uk. If you have any questions regarding which maintenance guide you should follow, please speak to a member of the Atkinson & Kirby team who will be able to help.