

Installation and Service Manual

Heat Pump air/water 'inverter'

HP40/50-4-1PHMB

HP40/50-5-1PHMB

HP40/50-7-1PHMB

HP40/50-8-1PHMB

HP40/50-11-1PHMB

HP40/50-13-1PHMB

HP40/50-11-3PHMB

HP40/50-13-3PHMB

IMPORTANT

Please read & understand all these instructions before commencing installation.

Please leave this manual with the customer for future reference.

Contents

1	Safety Precautions & Liabilities	
·	1.1 Safety Precautions	4
·	1.2 Manufacturer's liability	7
·	1.3 Installer's liability	7
·	1.4 User's liability	7
2	Important information about the refrigerant	8
3	General Introduction	9
4	Accessories	11
·	4.1 Accessories supplied with the unit	11
·	4.2 Accessories available from supplier	11
5	Before Installation	12
6	Installation Site	13
·	6.1 Selecting a location in cold climates	14
·	6.2 Selecting a location in hot climates	14
7	Installation Precautions	15
·	7.1 Dimensions	15
·	7.2 Installation requirements	15
·	7.3 Drain hole position	15
·	7.4 Servicing space requirements	16
8	Typical Applications	17
·	8.1 Application 1	18
·	8.2 Application 2	19
·	8.3 Cascade system	21
·	8.4 Buffer tank volume requirement	23
9	Overview of the unit	23
·	9.1 Disassembling the unit	23
·	9.2 Main components	24
·	9.3 Electronic control box	25
·	9.4 Water piping	34
·	9.5 Filling water	37
·	9.6 Water piping insulation	37
·	9.7 Field wiring	37
10	Start-up & Configuration	53
·	10.1 DIP switch settings overview	53
·	10.2 Initial start-up at low outdoor ambient temperature	54
·	10.3 Pre-operation checks	54
·	10.4 The circulation pump	55
·	10.5 Field settings	56
11	Final Checks & Test Run	67
·	11.1 Final checks	67
·	11.2 Test run operation (manually)	67
12	Maintenance & Service	67
13	Trouble Shooting	68
·	13.1 General guidelines	68
·	13.2 General symptoms	69
·	13.3 Operation parameter	71
·	13.4 Error codes	72
14	Final Checks & Test Run	78
·	14.1 Final checks	78
·	14.2 Test run operation (manually)	78
15	Information Servicing	79

Abbreviations:

Tbt1:	Buffer tank upper temperature sensor
Tbt2:	Buffer tank lower temperature sensor (for optional)
Tsolar:	Solar temperature sensor
T5:	DHW tank water temperature
T5S:	DHW set temperature
T4:	Outdoor temperature (°C)
T1:	Leaving water temperature (°C)
Pump_O:	Outside circulation pump
Pump_S:	Solar pump (Field supply)
Pump_I:	Water pump inside of the unit
Pump_D:	DHW pipe pump
IBH:	Backup electric heater
AHS:	Additional heat source
DHW:	Domestic heating water
TBH:	Tank Booster Heater

Homologations

Directives

This product complies with the requirements of the following European Directives and Standards:

- Pressure Equipment Directive 2014/68/EU
- Low Voltage Directive 2014/35/EU
Generic standard: EN 60335-1
Relevant standards: EN 60335-2-40,
- Electromagnetic Compatibility Directive 2014/30/EU
Relevant standard: EN 55014
- BS EN14511
- BS EN 14825

Installation reference guidance standards:

- BS EN 12831
- BS EN 14336
- BS7074
- BS 7593
- BS 4814
- BS 12828
- BS 7671 (IET) Wiring regulations.

This product conforms to the requirements of European Directive 2009/125/EC on the ecodesign of energy-related products.

In addition to the legal requirements and guidelines, the supplementary guidelines in this manual must also be followed.

Supplements or subsequent regulations and guidelines that are valid at the time of installation shall apply to all regulations and guidelines specified in this manual.

EC and UKCA Declarations of Conformity

It has been manufactured and commissioned in accordance with the European directives and Statutory requirements applicable. The unit complies with the standard type described in the EC declaration of conformity. It has been manufactured and commissioned in accordance with European directives.

The original declaration of conformity is available from the manufacturer.

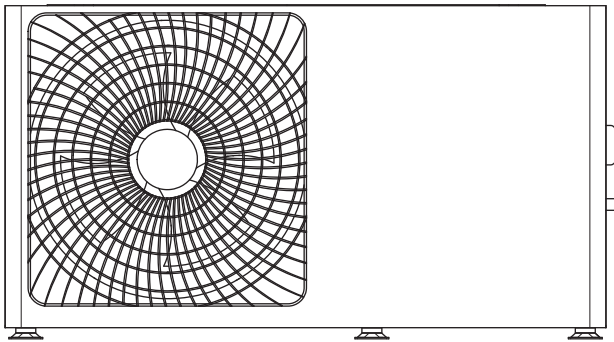

HP40/50-4-1PHM 4kW 1-phase
 HP40/50-5-1PHMB 5kW 1-phase

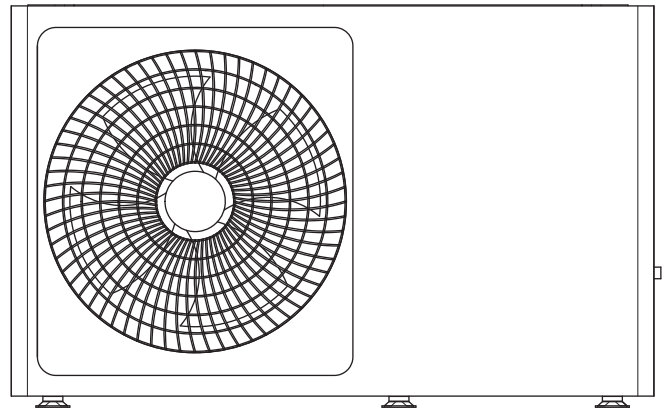

HP40/50-7-1PHMB 7kW 1-phase
 HP40/50-8-1PHMB 8kW 1-phase
 HP40/50-11-1PHMB 11kW 1-phase
 HP40/50-13-1PHMB 13kW 1-phase
 HP40/50-11-3PHMB 11kW 3-phase
 HP40/50-13-3PHMB 13kW 3-phase

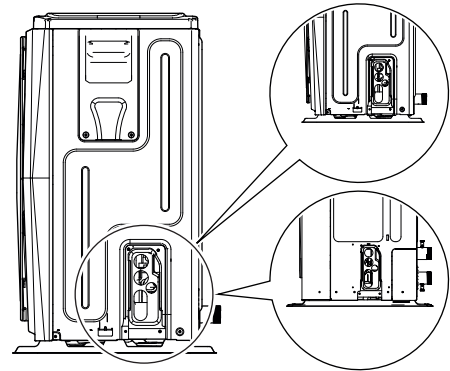
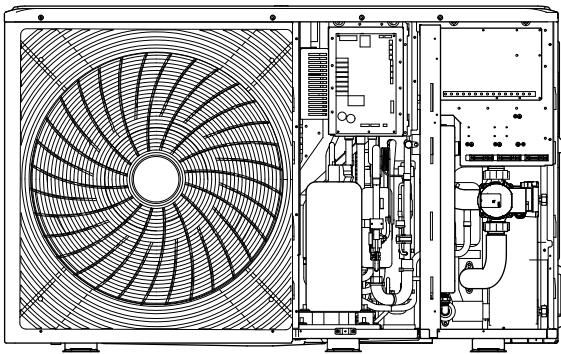

Please remove the transportation plate after installation

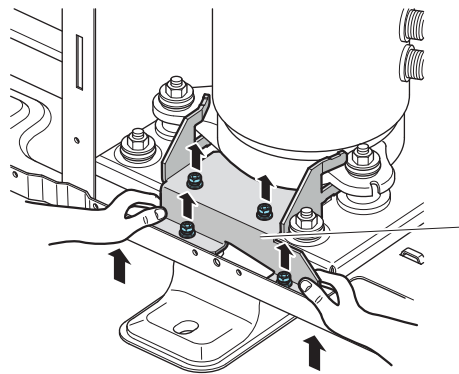
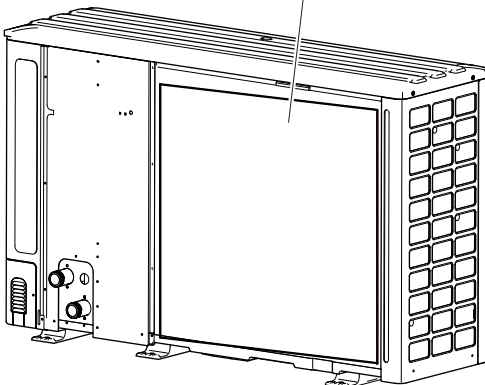

IMPORTANT: On 11 & 13kW models remove the transportation support. Failure to do so could damage the compressor.

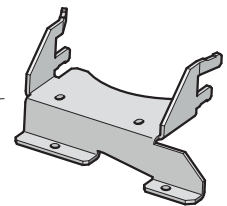

11/13kW

Fig. 1

NOTE

The pictures and functions described in this manual contain the (optional) backup heater components. Pictures in this manual are for reference only, please refer to the actual product.

Factory test

Before leaving the factory, each module is tested on the following items:

- Tightness of the heating circuit
- Electrical safety
- Tightness of the refrigerant circuit

1 Safety Precautions & Liabilities

1.1 Safety Precautions

The precautions listed here are divided into the following types. They are important, so be sure to follow them carefully.

Meanings of DANGER, WARNING, CAUTION and NOTE symbols.

i INFORMATION

- Read these instructions carefully before installation. Keep this manual readily available for future reference.
- Improper installation of equipment or accessories may result in electric shock, short-circuit, leakage, fire or other damage to the equipment. Be sure to only use accessories made by the supplier, which are specifically designed for the equipment and make sure to get installation done by a professional.
- All the activities described in this manual must be carried out by a competent and qualified technician. Be sure to wear adequate personal protection equipment such as gloves and safety glasses while installing the unit or carrying out maintenance activities.
- Contact your installer for further assistance.



Caution: Risk of fire/flammable materials

⚠ WARNING

Servicing shall only be performed as recommended by the equipment manufacturer. Maintenance and repair requiring the assistance of other skilled personnel shall be carried out under the supervision of the person competent in the use of flammable refrigerants.

⚠ DANGER

Indicates an imminently hazardous situation which if not avoided, will result in death or serious injury.

⚠ WARNING

Indicates a potentially hazardous situation which if not avoided, could result in death or serious injury.





⚠ CAUTION

Indicates a potentially hazardous situation which if not avoided, may result in minor or moderate injury. It is also used to alert against unsafe practices.

💡 NOTE

Indicates situations that could result in accidental equipment or property damage.

Explanation of symbols displayed on the monobloc.

	WARNING	This symbol shows that this appliance uses a flammable refrigerant. If the refrigerant is leaked and exposed to an external ignition source, there is a risk of fire.
	CAUTION	This symbol shows that the operation manual should be read carefully.
	CAUTION	This symbol shows that service personnel should be handling this equipment with reference to the installation manual.
	CAUTION	This symbol shows that service personnel should be handling this equipment with reference to the installation manual.
	CAUTION	This symbol shows that information is available such as the operating manual or installation manual.

DANGER

- Before touching electrical terminal parts, isolate from the mains power.
- When the service panel is removed, some components are live.
- Never leave the unit unattended during installation or servicing when the service panel is removed.
- Do not touch water pipes during or immediately after operation as the pipes may be hot and could burn. To avoid injury, give the pipework time to return to normal temperature or be sure to wear protective gloves.
- Do not touch any switch with wet fingers. Touching a switch with wet fingers can cause electrical shock.

WARNING

- Dispose of all plastic packaging bags so that children will not play with them. Children playing with plastic bags face danger of death by suffocation.
- Safely dispose of packing materials such as nails and other metal or wood parts that could cause injury.
- Ask your installer or qualified personnel to perform installation work in accordance with this manual. Do not install the unit yourself. Improper installation could result in water leakage, electric shocks, fire or the unit falling from its mount.
- Be sure to use only specified accessories and parts for installation work. Failure to use specified parts may result in water leakage, electric shocks, fire, or the unit falling from its mount.
- Install the unit on a flat and level foundation that can withstand its weight. Otherwise, it may cause damage to the equipment and possible personal injury.
- Perform specified installation work with full consideration of strong wind, hurricanes, or earthquakes. Improper installation work may result in accidents due to equipment falling.
- Make certain that all electrical work is carried out by qualified personnel according to the local laws and regulations and this manual using a separate circuit. Insufficient capacity of the power supply circuit or improper electrical construction may lead to electric shocks or fire.
- Be sure to install an earth fault circuit interrupter according to local laws and regulations. Failure to install a ground fault circuit interrupter may cause electric shocks and fire.

- Make sure all wiring is secure. Use the specified wires and ensure that terminal connections or wires are protected from water and other dangers.
- When wiring the power supply, form the wires so that the front panel can be securely fastened. If the front panel is not in place there could be overheating of the terminals, electric shocks or fire.
- After completing the installation work, check to make sure that there is no refrigerant leakage. Only a FGAS qualified technician can carry out a full leak test.
- Never directly touch any leaking refrigerant as it could cause severe frostbite. Do not touch the refrigerant pipes during and immediately after operation as the refrigerant pipes may be hot or cold, depending on the condition of the refrigerant flowing through the refrigerant piping, compressor and other refrigerant cycle parts. Burns or frostbite are possible if you touch the refrigerant pipes. To avoid injury, give the pipes time to return to normal temperature or, if you must touch them protective gloves must be worn.
- Do not touch the internal parts (pump, etc.) during and immediately after operation. The product can get very hot or cold.

CAUTION

- Earth the unit.
- Earth resistance should be according to local laws and regulations.
- Do not connect the earth wire to gas or water pipes, lightning conductors or telephone ground wires. Incomplete earthing may cause electric shocks.
 - Gas pipes: Fire or an explosion may occur if there is a gas leak.
 - Water pipes: Hard vinyl tubes are not effective earths.
 - Lightning conductors or telephone earth wires: Electrical threshold may rise abnormally if struck by a lightning bolt.
- Install the electrical supply at least 3 feet (1 meter) away from televisions or radios to prevent interference or noise. (Depending on the radio waves, a higher distance might be needed.)
- Do not wash the unit. This may cause electric shocks or fire. The appliance must be installed in accordance with national wiring regulations. If the supply wiring is damaged, it must be replaced by a qualified person.

- Do not install the unit in the following places:
 - Where there is mist of mineral oil, oil spray or vapors. Plastic parts may deteriorate, and cause them to come loose or water to leak.
 - Where corrosive gases (such as sulphurous acid gas) are produced. Where corrosion of copper pipes or soldered parts may cause refrigerant to leak.
 - Where there is machinery which emits electromagnetic waves. Electromagnetic waves can disturb the control system and cause equipment malfunction.
 - Where flammable or combustion gases may leak, where carbon fibre or ignitable dust is suspended in the air or where volatile flammables such as paint thinner or gasoline are handled. These types of gases might cause a fire.
 - Where the air contains high levels of salt such as near the ocean (less than 3km (1.8 miles) from the coastline).
 - Where voltage fluctuates a lot (maximum deviation of 15%), such as in factories.
 - In vehicles or vessels.
 - Where acidic or alkaline vapors are present.
- This appliance can be used by children 8 years old and above and persons with reduced physical, sensory or mental capabilities or lack of experience and knowledge if they are supervised or given instruction on using the unit in a safe manner and understand the hazards involved. Cleaning and user maintenance should not be done by children without supervision.
- Children should be supervised to ensure that they do not play with the appliance.
- **DISPOSAL:** Do not dispose of this product as unsorted municipal waste. Collection of such waste separately for special treatment is necessary. Do not dispose of electrical appliances as municipal waste, use separate collection facilities. Contact your local government for information regarding the collection systems available. If electrical appliances are disposed of in landfills or dumps, hazardous substance can leak into the groundwater and enter the food chain, damaging your health and well-being.
- The wiring must be performed by professional technicians in accordance with national wiring regulation and the circuit diagram. An all-pole disconnection device which has at least 3mm separation distance in all pole and a residual current device (RCD) with the rating not exceeding 30mA shall be incorporated in the fixed wiring according to the national rule.

- Confirm that the installation area (walls, floors, etc.) has no concealed services such as water, electricity, and gas, before wiring/pipes.
- Before installation, check whether the user's power supply meets the electrical installation requirements of unit (including reliable earthing, leakage, and wire diameter electrical load, etc.). If the electrical installation requirements of the product are not met, the installation of the product is prohibited until the supply is rectified.
- When installing multiple heat pumps in a centralised manner please confirm the load balancing of the power supply. Please ensure that any phase balancing is carried out by a relevant qualified person and to relevant standard.
- The product must be installed in such a manner that it is fixed firmly. Where necessary, reinforcement of the installation site must be carried out.

NOTE

About Fluorinated Gases

- This heat pump unit contains fluorinated gases. For specific information on the type of gas and the amount, please refer to the relevant label on the unit itself. Compliance with national gas regulations must be observed.
- Installation, service, maintenance and repair of this unit must be performed by a qualified competent person.
- Product uninstallation and recycling must be performed by a qualified competent person.
- See Chapter 2: Important Information About The Refrigerant.

1.2 Manufacturer's liability

Our products are manufactured in compliance with the requirements of various Regulations applicable. They are therefore delivered with the marking **CE** and any documents necessary. In the interests of the quality of the products, we strive constantly to improve them. We therefore reserve the right to modify the specifications given in this document.

Our liability as manufacturer may not be invoked in the following cases.

Failure to abide by the instructions on installing the appliance. Failure to abide by the instructions on using the appliance. Faulty or insufficient maintenance of the appliance.

1.3 Installer's liability

The installer is responsible for the installation and initial commissioning of the appliance. The installer must observe the following instructions:

Read and follow the instructions given in the manuals provided with the appliance.

Install the appliance in compliance with prevailing legislation and standards.

Carry out initial commissioning and any checks necessary. Explain the installation to the user.

If maintenance is necessary, warn the user of the obligation to check the appliance and keep it in good working order. Give all the instruction manuals to the user.

1.4 User's liability

To guarantee optimum operation of the system, you must abide by the following instructions:

Read and follow the instructions given in the manuals provided with the appliance.

Call on a qualified professional to carry out installation and initial commissioning.

Get your installer to explain your installation to you.

Have the required inspections and maintenance carried out by a qualified installer.

Keep the instruction manuals in good condition close to the appliance.

2 Important information about the refrigerant

Model	Factory charged refrigerant volume in the unit	
	Refrigerant/kg	Tonnes CO ₂ equivalent
4kW	1.40	0.95
5kW	1.40	0.95
7kW	1.40	0.95
8kW	1.40	0.95
11kW	1.75	1.18
13kW	1.75	1.18

This product contains R32, a fluorinated greenhouse gas (volume of Global Warming Potential: 675). Do not vent refrigerant to the atmosphere.

Compliance with national regulations shall be observed.

Only qualified professionals are authorized to carry out installation, maintenance, repair or removal work on the appliance and the heating installation. They must respect prevailing local and national regulations during fitting, installation and maintenance of the installation.

All work on the refrigeration circuit must be done by a F-Gas qualified professional, according to prevailing codes of practice and safety in the profession (recovery of the refrigerant, brazing under nitrogen).

By qualified professional, we mean a person who has the qualifications pertaining to this refrigerant handling and piping work as stipulated by the local laws and regulations, and who has been trained in matters relating to refrigerant handling and piping work.

Before working on the refrigeration circuit, switch off the appliance and wait a few minutes. Certain items of equipment such as the compressor and the pipes can reach temperatures in excess of 100°C and high pressures, which may cause serious injuries.

CAUTION

- Do not use means to accelerate the defrosting process or to clean, other than those recommended by the manufacturers.
- The appliance shall be stored in a room without continuously operating ignition sources (for example: open flames, an operating gas appliance or an operating electric heater).
- Do not pierce or burn.
- Be aware that refrigerants may not contain an odour.

The refrigerant inside the unit is flammable and toxic. If the refrigerant leaks in a room and comes in contact with fire from a burner, heater, or cooker, it may result in fire or the formation of a harmful gas. When a leak is detected, turn off any combustible heating devices, ventilate the room and contact the dealer from which you purchased the unit.

Do not use the unit until a qualified installer confirms that the portion from which the refrigerant leaked is repaired.

When installing, relocating, or servicing the heat pump, use only the specified refrigerant (R32) to charge the refrigerant lines. Do not mix it with any other refrigerant and do not allow air, liquids or other gases to remain in the lines.

Use tools and pipe components especially designed for use with R32 refrigerant.

Use copper pipes deoxidized with phosphorus to carry the refrigerant.

Store the refrigerant connection pipes away from dust and humidity (risk of damage to the compressor). Apply refrigerant oil to the flared parts to facilitate tightening and improve the seal.

Protect the heat pump components, including the insulation and structural elements. Do not overheat the pipes as brazed components may cause damage.

Protect pipe-work from physical damage.

Insulate the pipes to reduce heat losses to a minimum.

CAUTION

- Inspection and maintenance operations must be carried out at least once a year, by a qualified professional.
- Refrigerant leakage checks must be performed.

3 General Introduction

- These units are used for heating applications and domestic hot water tanks. They can be combined with fan coil units, floor heating applications, low temperature high efficiency radiators, domestic hot water tanks and solar kits, which are all field supplied.
- A wired controller is supplied with the unit.
- You have the option to purchase an optional backup heater. It can increase the heating capacity during cold outdoor temperature. The backup heater also serves as a backup in case of malfunctioning.

NOTE

- Maximum length of communication wiring between the indoor unit and the controller is 50m.
- Power cords and communication wiring must be laid out separately. They cannot be placed in the same conduit otherwise it may lead to electromagnetic interference. Power cords and communication wiring should not come in contact with the refrigerant pipe so as to prevent the high temperature pipe from damaging the wiring.
- Communication wiring must use shielded lines. Including indoor unit to outdoor unit PQE line, indoor unit to controller ABXYE line.

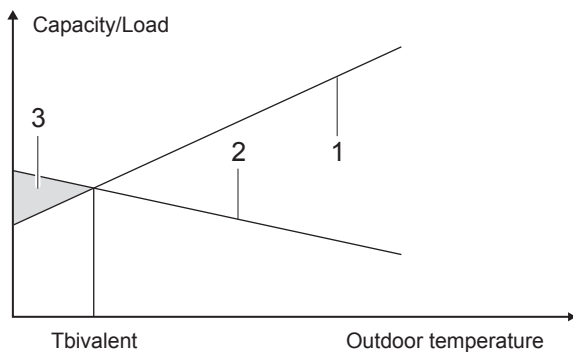

Fig. 2

- 1 Heat pump capacity.
- 2 Required heating capacity (site dependent).
- 3 Additional heating capacity provided by backup heater.

Domestic hot water tank (field supply)

A domestic hot water tank (with or without booster heater) can be connected to the unit.

The requirement of the tank is different for different unit and material of heat exchanger.

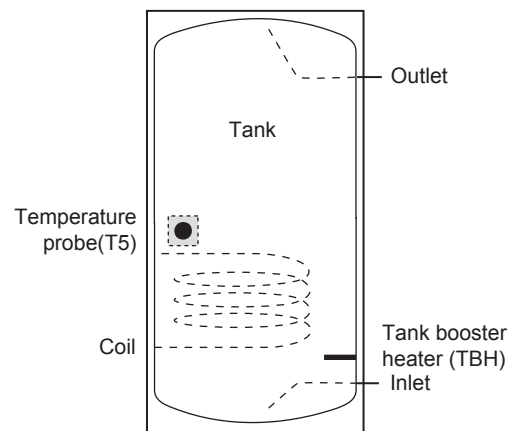

Fig. 3

The Tank booster heater (TBH) should be installed below the temperature probe (T5) (Fig. 3).

The heat exchanger (coil) should be installed below the temperature probe (Fig. 3).

It is recommended to limit the distance between the outdoor unit and the tank to 10 metres.

Model		4/5kW	7/8kW	11/13kW
Volume of tank/L	Recommended	100~250	150~300	200~300
Heat exchange area/m ² (Stainless steel coil)	Minimum	1.4	1.4	1.6
Heat exchange area/m ² (Enamel coil)	Minimum	2.0	2.0	2.5

Room thermostat (field supplied)

Room thermostat can be connected to the unit (room thermostat should be kept away from heating source when selecting the installation place).

Solar kit for domestic hot water tank (field supplied).

An optional solar kit can be connected to the unit.

Operation range

Outlet water (Heating mode)		+12 ~ +65°C
Outlet water (Cooling mode)		+5 ~ +25°C
Domestic hot water		+12 ~ +60°C
Ambient temperature		-25 ~ +43°C
Water pressure		1-3 bar (0.10-0.30 MPa)
Water flow	4kW	0.40 ~ 0.90m ³ /h
	5kW	0.40 ~ 1.25m ³ /h
	7kW	8kW 0.40 ~ 1.65m ³ /h
	8kW	10kW 0.40 ~ 2.10m ³ /h
	11kW	12kW 0.70 ~ 2.50m ³ /h
	13kW	16kW 0.70 ~ 3.00m ³ /h

The unit has a frost protection that uses the heat pump and the optional backup heater to keep the water system safe from freezing in all conditions. Unless power failure or lock out should occur (see 9.4 Water piping).

In heating mode, the water flowing temperature (TW_out) range in different outdoor temperature (T4) is listed below:

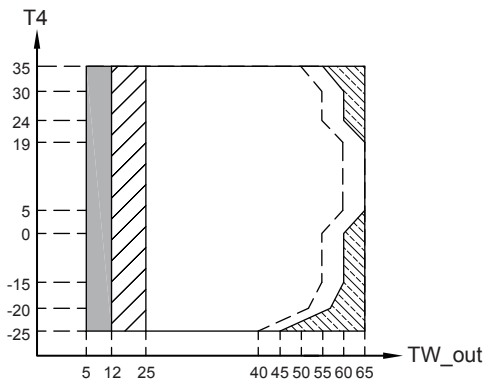

- If IBH/AHS setting is valid, only IBH/AHS turns on; If IBH/AHS setting is invalid, only heat pump turns on, limitation and protection may occur during heat pump operation.
- ▨ Operation range by heat pump with possible limitation and protection.
- ▩ Heat pump turns off, only IBH/AHS turns on.
- — Maximum inlet water temperature line for heat pump operation.

Fig. 4

In DHW mode, the water flowing temperature (TW_out) range in different outdoor temperature (T4) is listed below:

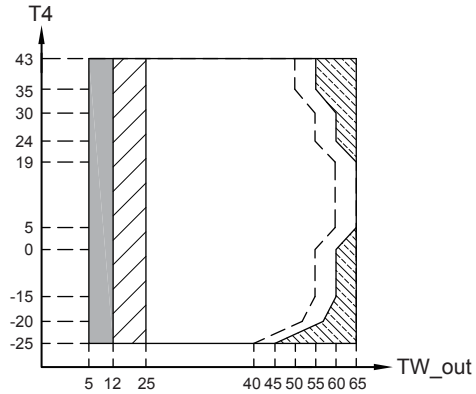













- If IBH/AHS setting is valid, only IBH/AHS turns on; If IBH/AHS setting is invalid, only heat pump turns on, limitation and protection may occur during heat pump operation.
- ▨ Operation range by heat pump with possible limitation and protection.
- ▩ Heat pump turns off, only IBH/AHS turns on.
- — Maximum inlet water temperature line for heat pump operation.

Fig. 5











Temperature is listed in °C. IBH/AHS is internal Backup Heater/Additional Heating source.

4 Accessories

4.1 Accessories supplied with the unit

Installation Fittings		
Name	Shape	Quantity
Installation, user and service manual (this book)		1
User operations manual		1
Installer operation manual		1
Technical data manual		1
Y-shape filter		1
Thermistor for domestic hot water tank or zone2 water flow or buffer tank		1
Drain Hose		1
Energy label		1
Tighten belt for customer wiring use		2
		3
ADEY Magnetic filter		1
Wired controller		1

4.2 Additional accessories available from Baxi

Name	Shape	Quantity
Thermistor for buffer tank (Tbt1)		1
Extension wire for Tbt1		1
Thermistor for Zone 2 flow temp. (Tw2)		1
Extension wire for Tw2		1
Thermistor for solar temp.(Tsolar)		1
Extension wire for Tsolar		1
Backup heater:3kW or 4 .5kW		1
Buffer tank		1
Water temperature thermistor		1
3 port valve		1
Mounted feet		3

* Contact your supplier for more details about availability.

5 Before Installation

Before Installation

Be sure to confirm the model name and the serial number of the unit. They are pasted on the side panel of the unit body.

Handling

Due to relatively large dimensions and heavy weight, the unit should only be handled using lifting tools with slings. The slings can be fitted into foreseen sleeves at the base frame that are made specifically for this purpose.

⚠ CAUTION

- To avoid injury, do not touch the air inlet or aluminum fins of the unit.
- Do not use the grips in the fan grills to avoid damage.
- The unit is top heavy! Prevent the unit from falling due to improper inclination during handling.

The position of centre of gravity for different units can be seen below.

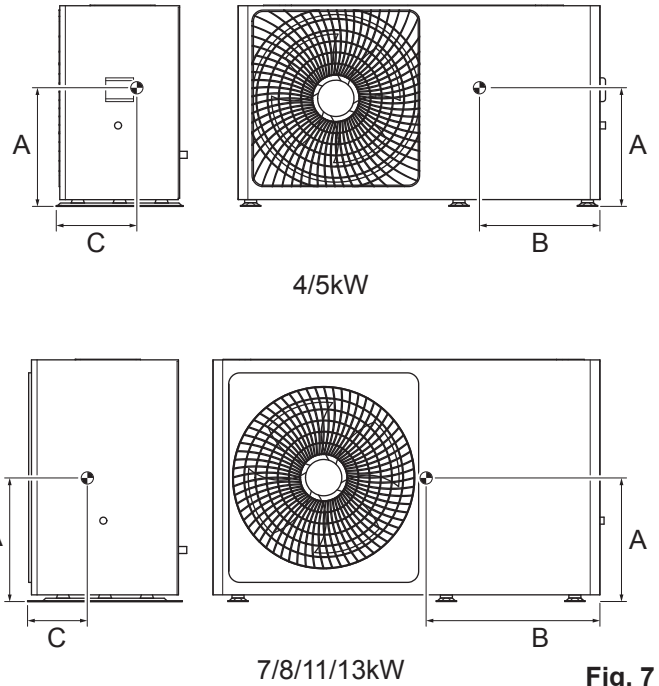

Fig. 7

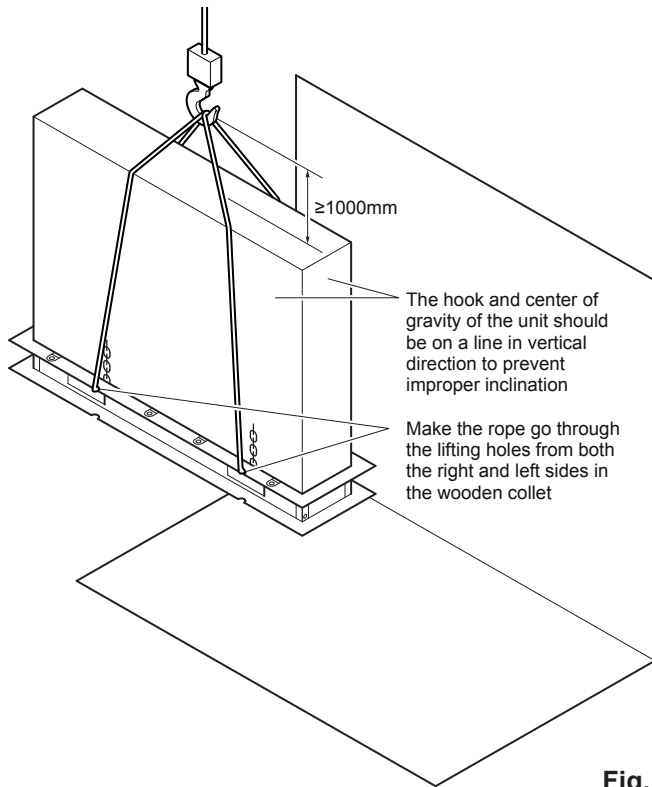

Fig. 6

Model	A (mm)	B (mm)	C (mm)
4/5kW 1-phase	370	540	190
7/8kW 1-phase	410	580	280
11/13kW 1-phase	370	605	245
11/13kW 3-phase	280	605	245

6 Installation Site

⚠ WARNING

There is flammable refrigerant in the unit and it should be installed in a well-ventilated site.

- Select an installation site where the following conditions are satisfied and one that meets with your customer's approval.
 - Places that are well-ventilated.
 - Places where the unit does not disturb neighbours.
 - Safe places which can bear the unit's weight and vibration and where the unit can be installed at an even level.
 - Places where there is no possibility of flammable gas or product leak.
 - The equipment is not intended for use in a potentially explosive atmosphere.
 - Places where servicing space can be well ensured.
 - Places where the unit's piping and wiring lengths come within the allowable ranges.
 - Places where water leaking from the unit cannot cause damage to the location (e.g. in case of a blocked drain pipe).
 - Places where rain can be avoided as much as possible.
- Do not install the unit in places often used as a work space. In case of construction work (e.g. grinding etc.) where a lot of dust is created, the unit must be covered.
- Do not place any object or equipment on top of the unit (top plate).
- Do not climb, sit or stand on top of the unit. Do not locate under trees or bushes as foliage can block the heat exchanger/evaporator affecting the units performance.
- Be sure that sufficient precautions are taken in case of refrigerant leakage according to relevant local laws and regulations.
- When installing the unit in a place exposed to strong wind, pay special attention to the following.

Strong winds blowing against the unit's air outlet causes a short circuit (suction of discharge air), and this may have the following consequences:

- Deterioration of the operational capacity.

- Frequent frost acceleration in heating operation.
- Disruption of operation due to rise of high pressure.
- When a strong wind blows continuously on the front of the unit, the fan can start rotating very fast until it breaks.

In normal condition, refer to the figures below for installation of the unit:

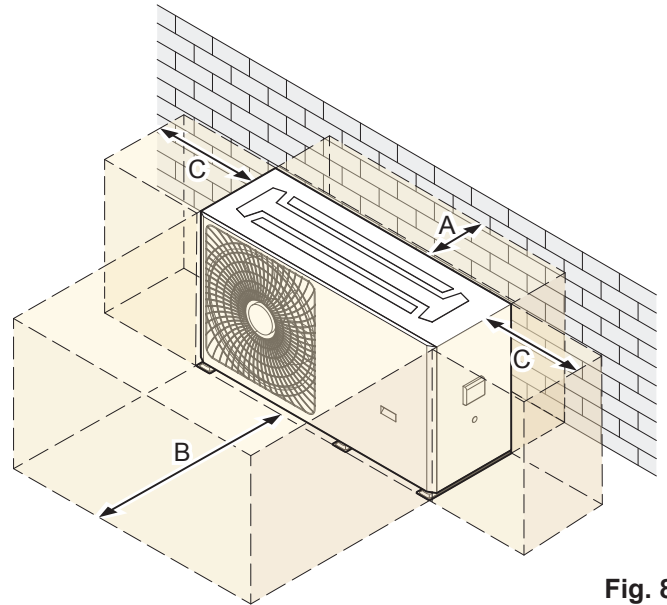

Fig. 8

In case of strong wind towards the heat pump, the orientation can be reversed. Turn the air outlet side towards the building, fence or screen (B Fig. 8).

Model	A (mm)	B (mm)	C (mm)
4/5kW	>300	>1000	500
7/8/11/13kW	>300	>1500	500

Make sure there is enough room to do the installation.

Set the outlet side at a right angle to the direction of the wind (Fig. 9).

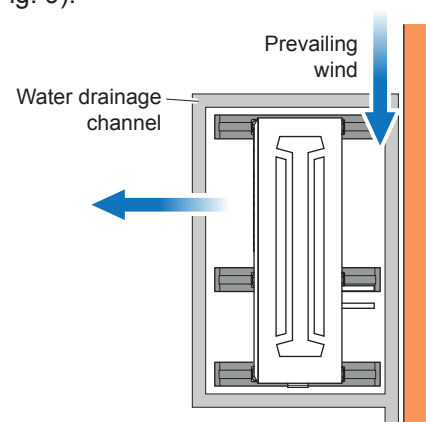

Fig. 9

- Prepare a water drainage channel around the foundation to drain waste water away from the unit.
- If water does not easily drain from the unit, mount the unit on a foundation of concrete blocks etc. (the height of the foundation should be about 100mm (3.93in)).

- When installing the unit in a place frequently exposed to snow, pay special attention to elevate the foundation as high as possible.

6.1 Selecting a location in cold climates

Refer to 'Handling' in section 4 Before installation.

NOTE

When operating the unit in cold climates, be sure to follow the instructions described below.

Never install the unit at a site where the suction side may be exposed directly to wind.

Avoid locations where the unit can be covered by snow. In areas where heavy snow fall is anticipated, special precautions such as raising the installation location or installing a hood on the air intake must be taken to prevent the snow from blocking the air intake or blowing directly against it. This can reduce the airflow and a malfunction may result.

6.2 Selecting a location in hot climates

An outdoor air thermistor is located at the back of the outdoor unit to measure temperature. To avoid it being heated by direct sunlight, you can for example install the outdoor unit in the shade or under a field-supplied canopy.

7 Installation Precautions

7.1 Dimensions

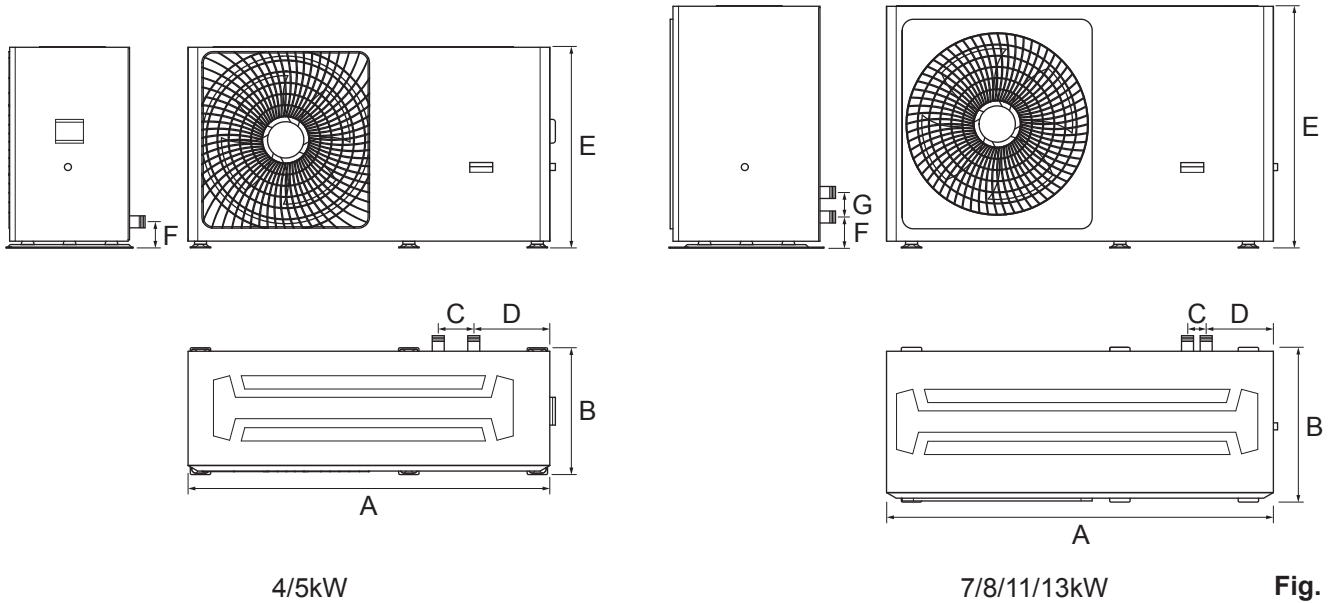

Model	A (mm)	B (mm)	C (mm)	D (mm)	E (mm)	F (mm)	G (mm)
4/5kW	1295	429	105	225	692	161	/
7/8/11/13kW	1385	526	60	221	845	182	81

7.2 Installation requirements

- Check the strength and level of the installation ground so that the unit may not cause any vibrations or noise during its operation.
- In accordance with the foundation drawing in the figure, fix the unit securely by means of foundation bolts. (Prepare four sets each of \varnothing 10mm Expansion bolts, nuts and washers which are readily available in the market.)
- Screw in the foundation bolts until their length is 20 mm from the foundation surface.

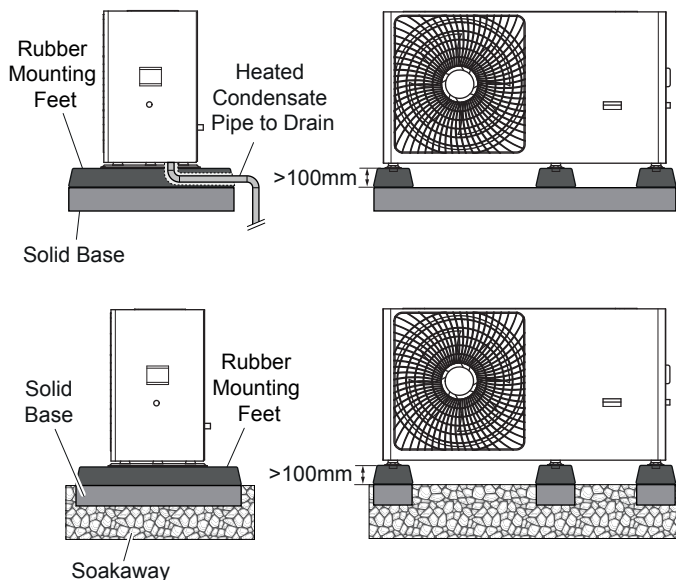

7.3 Drain hole position

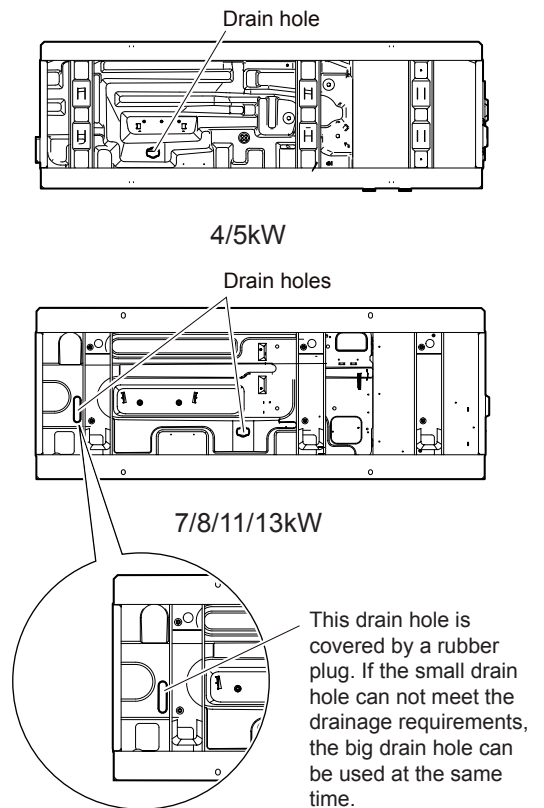

NOTE

It is necessary to install an electrical trace heating if water cannot drain out in cold weather even if the big drain hole has opened.

7.4 Servicing space requirements

7.4.1 In case of stacked installation

1. In case obstacles exist in front of the outlet side.

2. In case obstacles exist behind the outlet side.

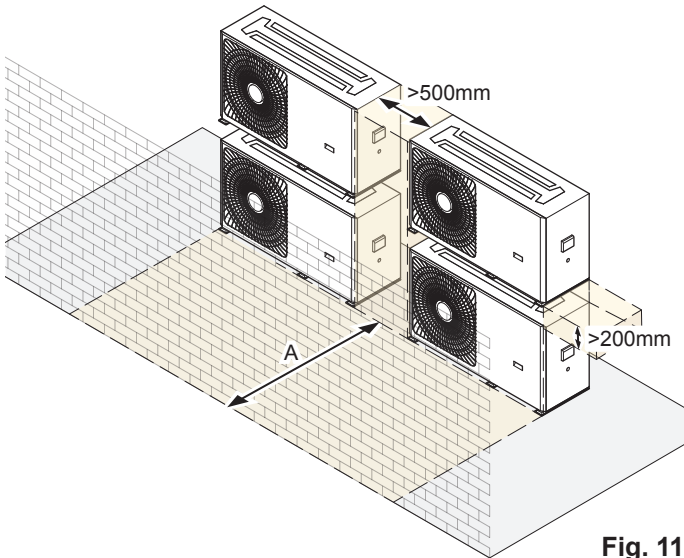

Fig. 11

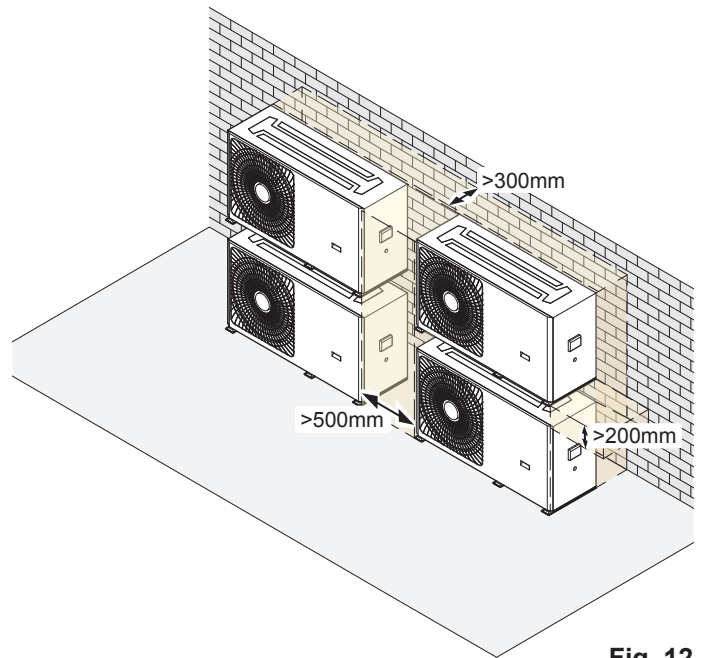

Fig. 12

Model	A (mm)
4/5kW	>1000
7/8/11/13kW	>1500

7.4.2 In case of multiple-row installation (for roof top use, etc.)

In case of installing multiple units in lateral connection per row.

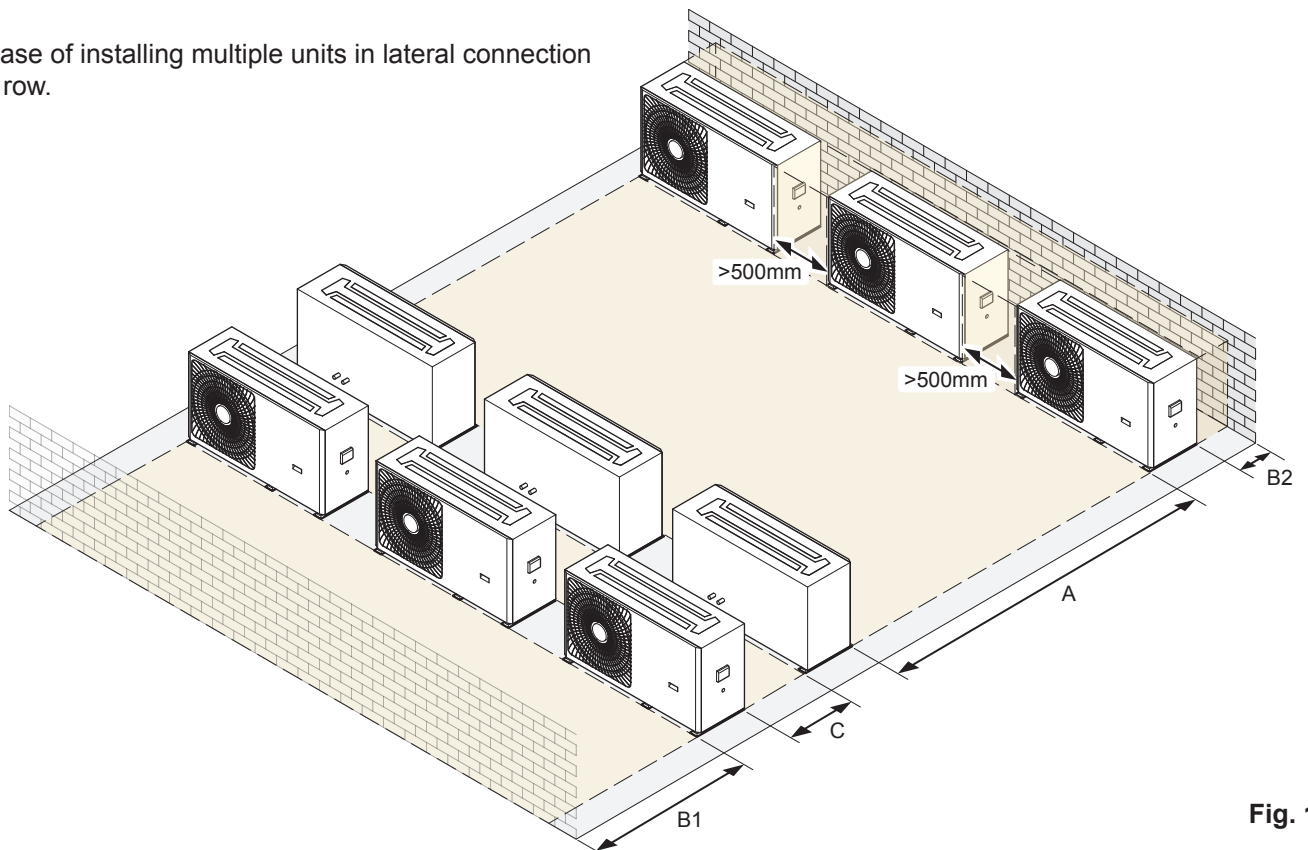

Fig. 13

Model	A (mm)	B1 (mm)	B2 (mm)	C (mm)
4/5kW	>2500	>1000	>300	>600
7/8/11/13kW	>3000	>1500	>300	>600

8 TYPICAL APPLICATIONS

The application examples given below are for illustration only.

8.1 Application 1

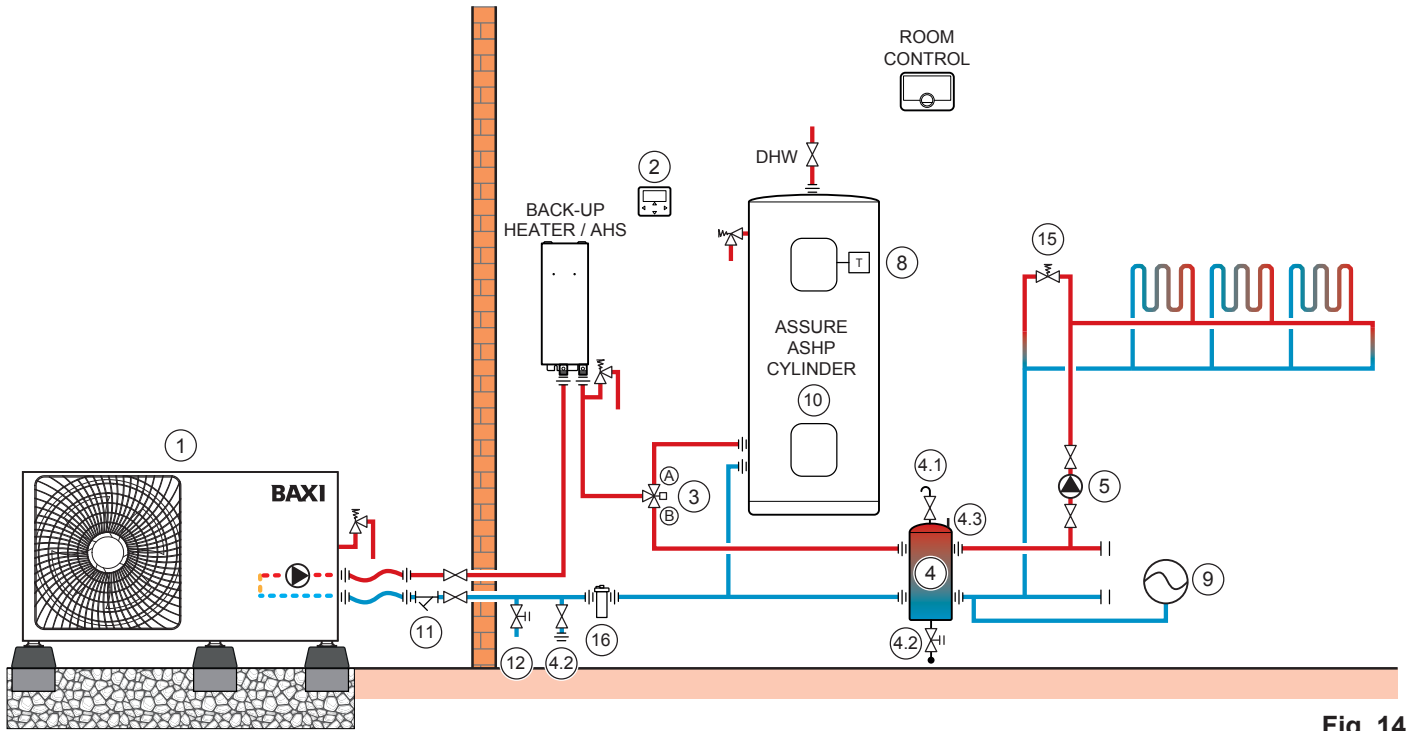

Fig. 14

No.	Assembly unit	No.	Assembly unit
1	Main unit	8	T5: Domestic water tank temperature sensor (Accessory)
2	User interface	9	Expansion vessel (Field supply)
3	SV1: 3-way valve (Field supply)	10	Domestic hot water tank (Field supply)
4	Buffer tank (Field supply)	11	Y Strainer (Filter)
4.1	Automatic air purge valve	12	Shut-off valve (Field supply)
4.2	Drainage valve	13	Filling valve (Field supply)
4.3	Tbt1: Buffer tank upper temperature sensor (Optional)	14	Drainage valve (Field supply)
5	P_o: Outside circulation pump (Field supply)	15	Bypass valve (Field supply)
7	P_d: DHW pipe pump (Field supply)	16	Magnetic filter

Space heating

The ON/OFF signal and operation mode and temperature setting are set on the user interface. P_o keeps running as long as the unit is ON for space heating, SV1 keeps OFF.

The ON/OFF signal and target tank water temperature (T5S) are set on the user interface. P_o stops running as long as the unit is ON for domestic water heating, SV1 keeps ON.

Back up Heater Control (BUH)

The BUH function is set on the hydraulic main board (see 10.1 DIP switch settings overview)

- 1) When the BUH is set to be valid only for heating mode, BUH can be turned on in the following ways:
 - a. Turn on the BUH via BACKHEATER function on the user interface;
 - b. BUH will be turned on automatically if initial water temperature is too low or target water temperature is too high at low ambient temperature. P_o keeps running as long as the BUH is ON, SV1 keeps OFF.
- 2) When the BUH is set to be valid for heating mode and DHW mode. In heating mode, BUH control is same as part 1); In DHW mode, BUH will be turned on automatically when the initial domestic water temperature T5 is too low or the target domestic water temperature is too high at low ambient temperature. P_o stops running, SV1 keeps ON.
- 3) When the BUH is set to be valid, M1M2 can be set to be valid on the user interface. In heating mode, BUH will be turned on if M1M2 dry contact closes. This function is invalid in DHW mode.

TBH (tank booster heater) control

The TBH function is set on the user interface. (see 10.1 DIP switch settings overview)

- 1) When the TBH is set to be valid, TBH can be turned on via TANKHEATER function on the user interface; In DHW mode, TBH will be turned on automatically when the initial domestic water temperature T5 is too low or the target domestic water temperature is too high at low ambient temperature.
- 2) When the TBH is set to be valid, M1M2 can be set to be valid on the user interface. TBH will be turned on if M1M2 dry contact closes.

NOTE

Make sure to fit the (SV1) 3-way valve correctly. For more details, (see 9.7.6 Connection for other components).

At extremely low ambient temperature, the domestic hot water is exclusively heated by TBH, which assures that the heat pump can be used for space heating with full capacity.

Details on domestic hot water tank configuration for low outdoor temperatures (T4DHWMIN) (see 10.5.1 DHW Mode Setting).

CAUTION

The highest outlet water temperature may reach 70°C, please beware of burning.

8.2 Application 2

ROOM THERMOSTAT Control for Space heating or cooling need to be set on the user interface. It can be set in three ways: MODE SET/ONE ZONE/DOUBLE ZONE. The monobloc can be connected to a high voltage room thermostat and a low voltage room thermostat.

8.2.1 One zone control

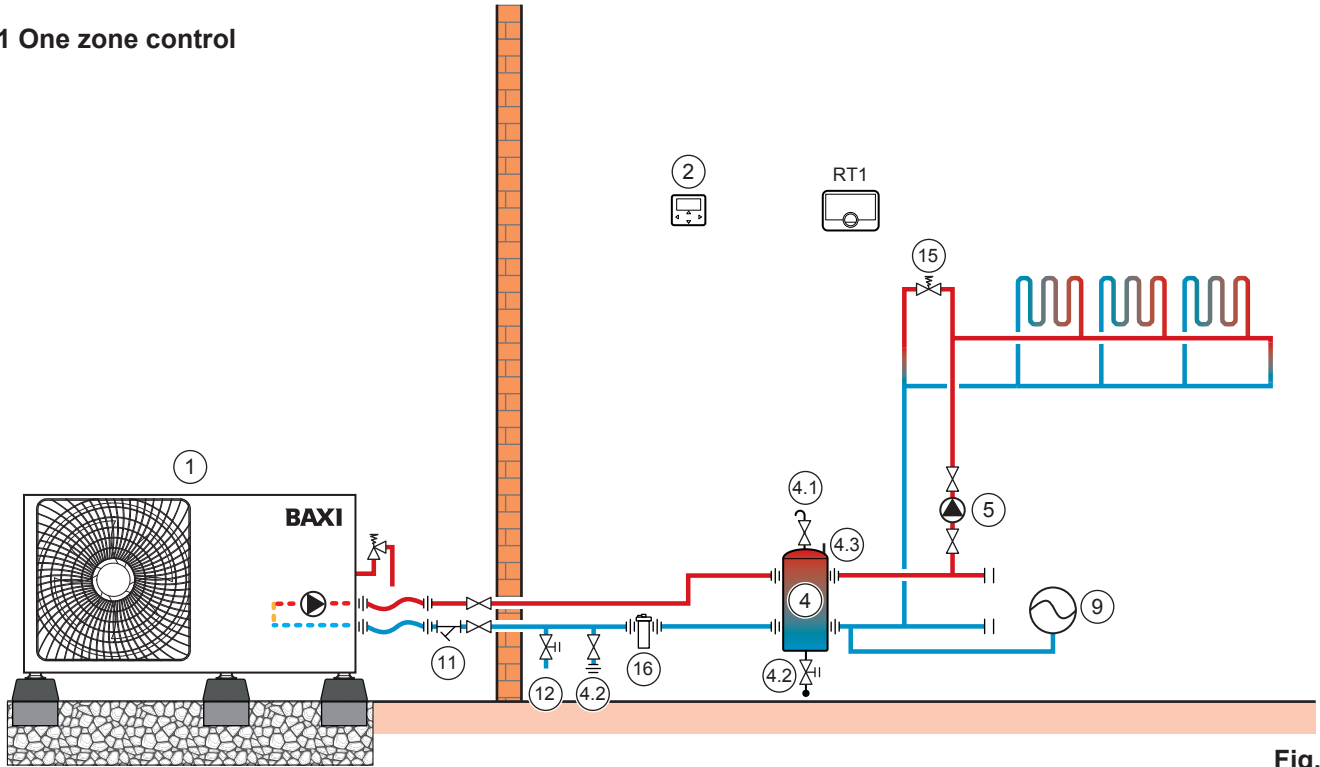

Fig. 15

No.	Assembly unit	No.	Assembly unit
1	Main unit	12	Shut-off valve (Field supply)
2	User interface	13	Filling valve (Field supply)
4	Buffer tank (Field supply)	14	Drainage valve (Field supply)
4.1	Automatic air purge valve	16	Magnetic filter
4.2	Drainage valve	19	Collector/distributor (Field supply)
5	P_o: Outside circulation pump (Field supply)	21	Thermostat transfer board (Optional)
9	Expansion vessel (Field supply)	RT 1...7	Room thermostat (Field supply)
11	Y Strainer (Filter)	FHL 1...n	Floor heating loop (Field supply)

Space heating

The unit ON/OFF is controlled by the room thermostat, cooling or heating mode and outlet water temperature are set on the user interface. System is ON when any "HL" of all the thermostats closes. When all "HL" open, system turns OFF.

The circulation pumps operation

When the system is ON, which means any "HL" of all the thermostats closes, P_o starts running; When the system is OFF, which means all "HL" close, P_o stops running.

8.2.2 Mode set control

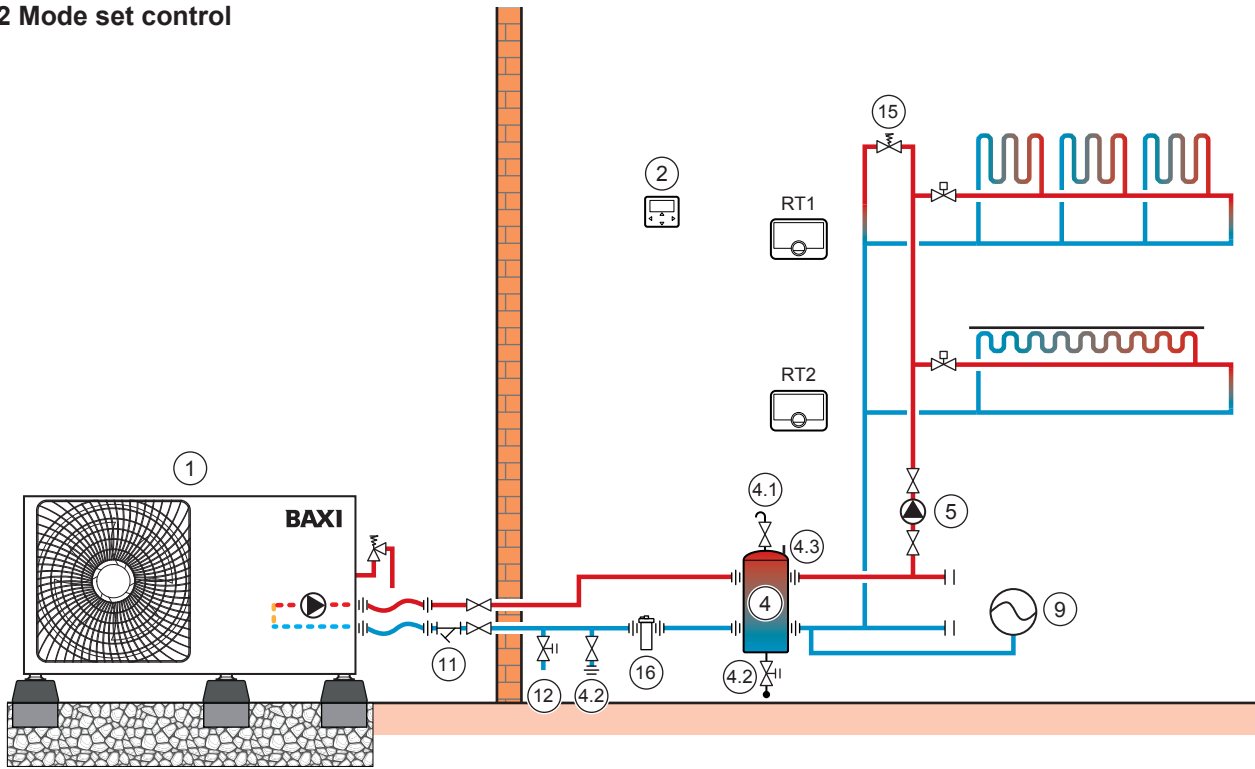

Fig. 16

No.	Assembly unit	No.	Assembly unit
1	Main unit	14	Drainage valve (Field supply)
2	User interface	16	Magnetic filter
4	Buffer tank (Field supply)	19	Collector/distributor (Field supply)
4.1	Automatic air purge valve	20	Bypass valve (Field supply)
4.2	Drainage valve	21	Thermostat transfer board (Optional)
5	P_o: Outside circulation pump (Field supply)	22	SV2: 3-way valve (Field supply)
9	Expansion vessel (Field supply)	RT 1...7	Room thermostat (Field supply)
11	Y Strainer (Filter)	FHL 1...n	Floor heating loop (Field supply)
12	Shut-off valve (Field supply)	FCU 1...n	Fan coil unit (Field supply)
13	Filling valve (Field supply)		

Space heating

Cooling or heating mode is set via the room thermostat, water temperature is set on the user interface.

- 1) When any 'CL' of all the thermostats close, system will be set at cooling mode.
- 2) When any 'HL' of all the thermostats close and all 'CL' open, system will be set at heating mode.

The circulation pumps operation

- 1) When the system is in cooling mode, which means any 'CL' of all the thermostats closes, SV2 keeps OFF, P_o starts running.
- 2) When the system is in heating mode, which means one or more 'HL' close and all 'CL' open, SV2 keeps ON, P_o starts running.

8.3 Cascade system

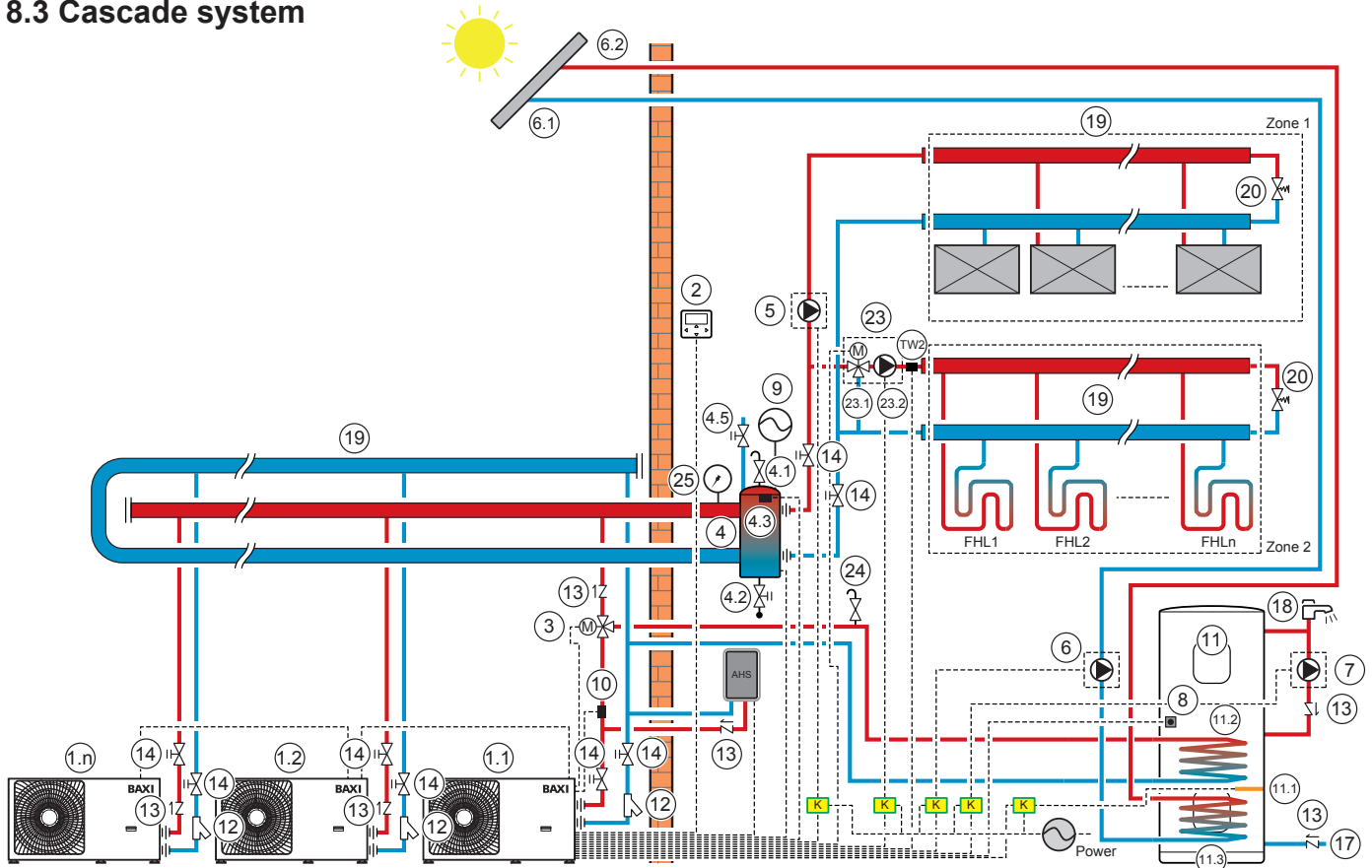

Fig. 17

No.	Assembly unit	No.	Assembly unit
1.1	Master unit	11.3	Coil 2, heat exchanger for Solar energy
1.2...n	Slave unit	12	Filter (Accessory)
2	User interface	13	Check valve (Field supply)
3	SV1: 3-way valve (Field supply)	14	Shut-off valve (Field supply)
4	Buffer tank (Field supply)	17	Tap water inlet pipe (Field supply)
4.1	Automatic air purge valve	18	Hot water tap (Field supply)
4.2	Drainage valve	19	Collector/distributor (Field supply)
4.3	Tbt1: Balance tank upper temperature sensor (optional)	20	Bypass valve (Field supply)
4.5	Filling valve	23	Mixing station (Field supply)
5	P_O: Outside circulation pump (Field supply)	23.1	SV3: Mixing station (Field supply)
6	P_S: Solar pump (Field supply)	23.2	P_C: Zone2 circulation pump (Field supply)
6.1	Tsolar: Solar temperature sensor (optional)	24	Automatic air purge valve (Field supply)
6.2	Solar panel (Field supply)	25	Water manometer (Field supply)
7	P_D: DHW pipe pump (Field supply)	TW2	Zone2 water flow temperature sensor (Optional)
8	T5: Domestic water tank temperature sensor (Accessory)	FCU1...n	Fan coil unit (Field supply)
9	Expansion vessel (Field supply)	FHL1...n	Floor heating loop (Field supply)
10	T1: Total water flow temperature sensor (Optional)	K	Contactors (Field supply)
11	Domestic hot water tank (Field supply)	ZONE1	The space operate cooling or heating mode
11.1	TBH: Domestic hot water tank booster heater	ZONE2	The space only operate heating mode
11.2	Coil 1, heat exchanger for heat pump	AHS	Auxiliary heat source (Field supply)

Domestic water heating

Only master unit (1.1) can operate in DHW mode. T5S is set on the user interface (2). In DHW mode, SV1 (3) keeps ON. When master unit is operated in DHW mode, slave units can operate in space cooling/heating mode.

Slave heating

All slave units can operate in space heating mode. The operation mode and setting temperature are set on the user interface (2). Due to changes of the outdoor temperature and the required load indoors, multiple outdoor units may operate at different times.

- In cooling mode, SV3 (23.1) and P_C (23.2) keep OFF, P_O (5) Keeps ON.
- In heating mode, when both ZONE 1 and ZONE 2 work, P_C (23.2) and P_O (5) keeps ON, SV3 (23.1) switches between ON and OFF according to the set TW2.
- In heating mode, when only ZONE 1 works, P_O (5) keeps ON, SV3 (23.1) and P_C (23.2) keeps OFF.
- In heating mode, when only ZONE 2 works, P_O (5) keeps OFF, P_C (23.2) keeps ON, SV3 (23.1) switches between ON and OFF according to the set TW2.

AHS (Auxiliary heat source) Control

AHS should be set via the dip switches on the main board (see 10.1); AHS is only controlled by the master unit. When the master unit operates in DHW mode, AHS can only be used for producing domestic hot water. When the master unit operates in heating mode, AHS can only be used for heating mode.

- 1) When AHS is set it is valid only in heating mode, it will be turned on in the following conditions:
 - a. Turn on BACKUPHEATER function on user interface.
 - b. Master unit operates in heating mode. When inlet water temperature is too low, or while ambient temperature is too low, the target leaving water temperature is too high, AHS will be turned on automatically.
- 2) When AHS is set valid in heating mode and DHW mode, it will be turned on in following conditions:
 - a. When master unit operates in heating mode, conditions of turning on AHS is the same as 1).
 - b. When master unit operates in DHW mode, if T5 is too low or when the ambient temperature is too low, target T5 temperature is too high, AHS will be turned on automatically.
- 3) When AHS is valid, and the operation of AHS is controlled by M1M2. When M1M2 closes, AHS will turn on. When master unit operates in DHW mode, AHS cant be turned on by closing M1M2.

TBH (Tank booster heater) Control

TBH should be set via the dip switches on the main board (see 10.1). TBH is only controlled by the master unit (see 8.1 for specific TBH control).

Solar energy Control

Solar energy is only controlled by the master unit. (see '8.1' for specific Solar energy Control).

NOTE

Maximum of 6 units can be cascaded in one system. One is the master unit, the others are slave units. The master unit and slave units are distinguished by whether connected to wired controller while powering on. The unit with the wired controller is the master unit, units without a wired controller are slave units. Only the master unit can operate in DHW mode. When installing, please check the cascade system diagram and determine the master unit. Before powering on, remove all wired controllers of slave units.

SV1, SV2, SV3, P_O, P_C, P_S, T1, T5, TW2, Tbt1, Tsolar, SL1, SL2, AHS, TBH interface only need to be connected to corresponding terminals on the main board of the master unit, (see 9.3.3 and 9.7.6).

The system has an auto-addressing function. After initial powering on, the master unit will assign addresses for slave units. The slave units will keep the addresses and wont need to be set again.

It is suggested to use the reversed return water system in order to avoid hydraulic imbalance between each unit in a cascade system.

CAUTION

In cascade systems, Tbt1 sensor must be connected to the master unit and set Tbt1 valid on the user interface (see 10.5.15).

If outside the circulation pump needs to be connected in series. In systems when the head of internal water pump is not enough, an outside circulation pump is suggested to be installed after the balance tank.

Please ensure that the maximum interval of power-on time of all units doesn't exceed 2 mins, otherwise the time for querying and allocating addresses will be missed. This may cause the slaves to fail to communicate normally and report Hd error.

The outlet pipe of each unit must be installed with a check valve.

8.4 Buffer tank volume requirement

Model	Buffer tank (L)
4/5/7/8kW	>25
11/13kW	>40
Cascade system	>40*n
n = number of outdoor units	

9 Overview of the unit

9.1 Disassembling the unit

Door 1 To access the compressor, electrical parts and hydraulic compartment.

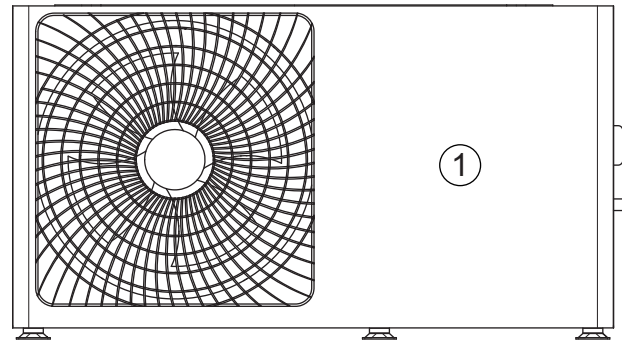

4/5kW

Fig. 18

Door 1 To access the compressor, electrical parts and hydraulic compartment.

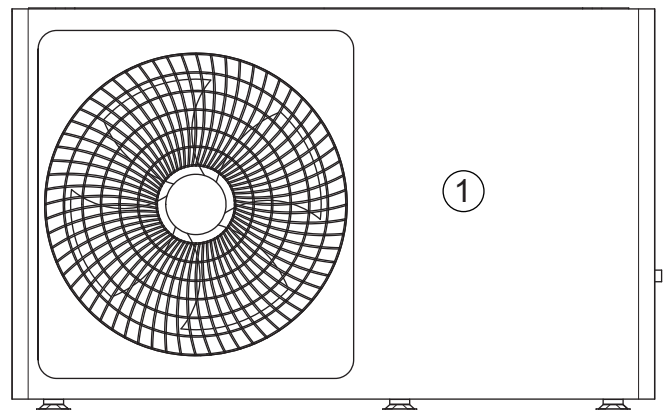

7/8/11/13kW

Fig. 19

⚠ WARNING

Switch off all power - unit power supply and backup heater and domestic hot water tank power supply (if applicable) - before removing door 1.

Parts inside the unit may be hot.

9.2 Main components

9.2.1 Hydraulic module

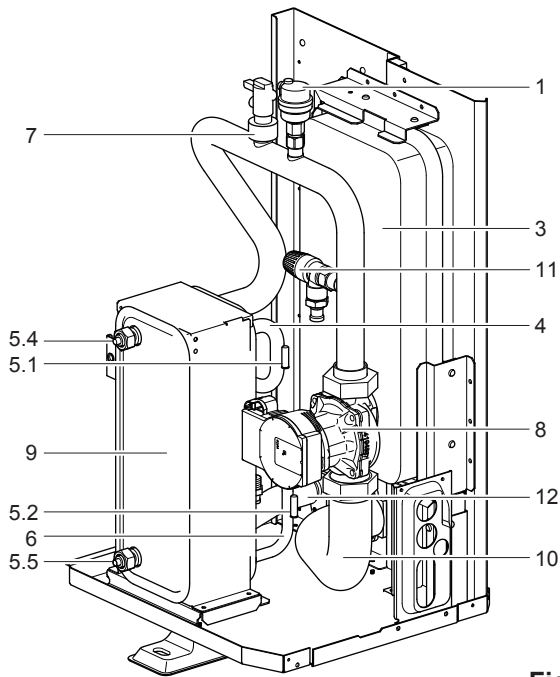

Fig. 20

4/5kW

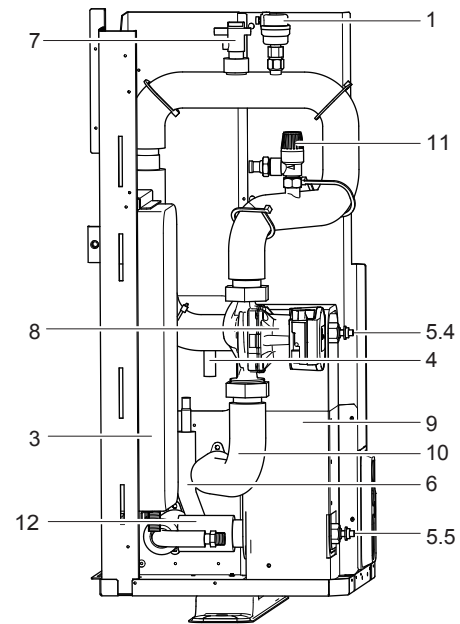

Fig. 21

7/8/11/13kW

No.	Assembly unit	Explanation
1	Automatic air purge valve	Remaining air in the water circuit will be automatically removed from the water circuit.
-	Backup heater (optional)	Provides additional heating capacity when the heating capacity of the heat pump is insufficient due to very low outdoor temperature. Also protects the external water pipes from freezing.
3	Expansion vessel	Balances water system pressure.
4	Refrigerant gas pipe	/
5	Temperature sensor	Four temperature sensors determine the water and refrigerant temperature at various points in the water circuit. 5.1-T2B; 5.2-T2; 5.4-TW_out; 5.5-TW_in
6	Refrigerant liquid pipe	/
7	Flow switch	Detects water flow rate to protect compressor and water pump in the event of insufficient water flow.
8	Pump	Circulates water in the water circuit.
9	Plate heat exchanger	Transfer heat from the refrigerant to the water.
10	Water outlet pipe	/
11	Pressure relief valve	Prevents excessive water pressure by opening at 3 bar (0.3 MPa) and discharging water from the water circuit.
12	Water inlet pipe	/

9.3 Electronic control box

NOTE

The picture is for reference only, please refer to the actual product.

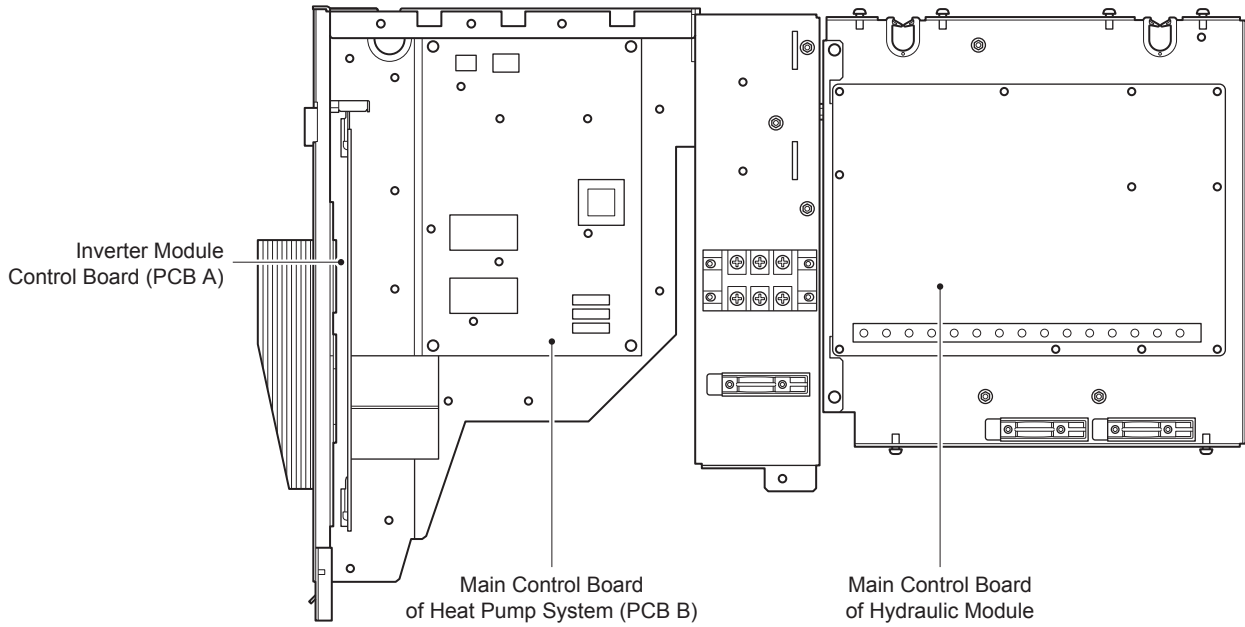

Fig. 22

4/5kW

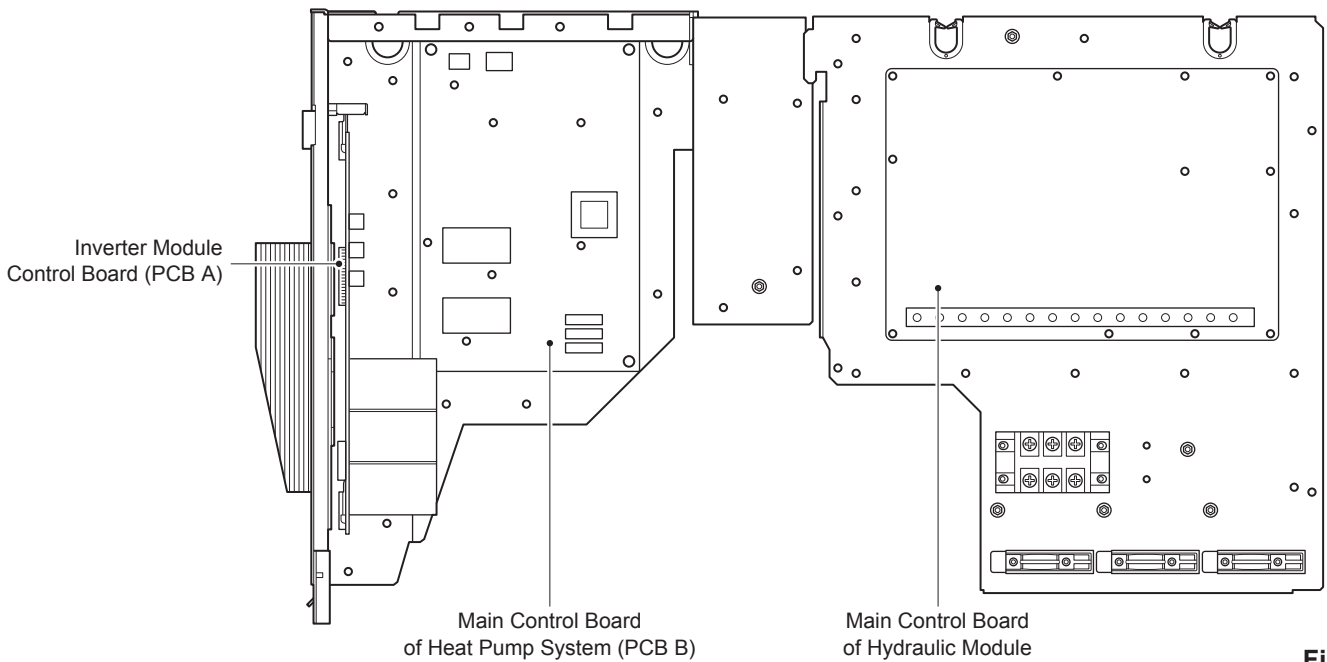

Fig. 23

7/8kW

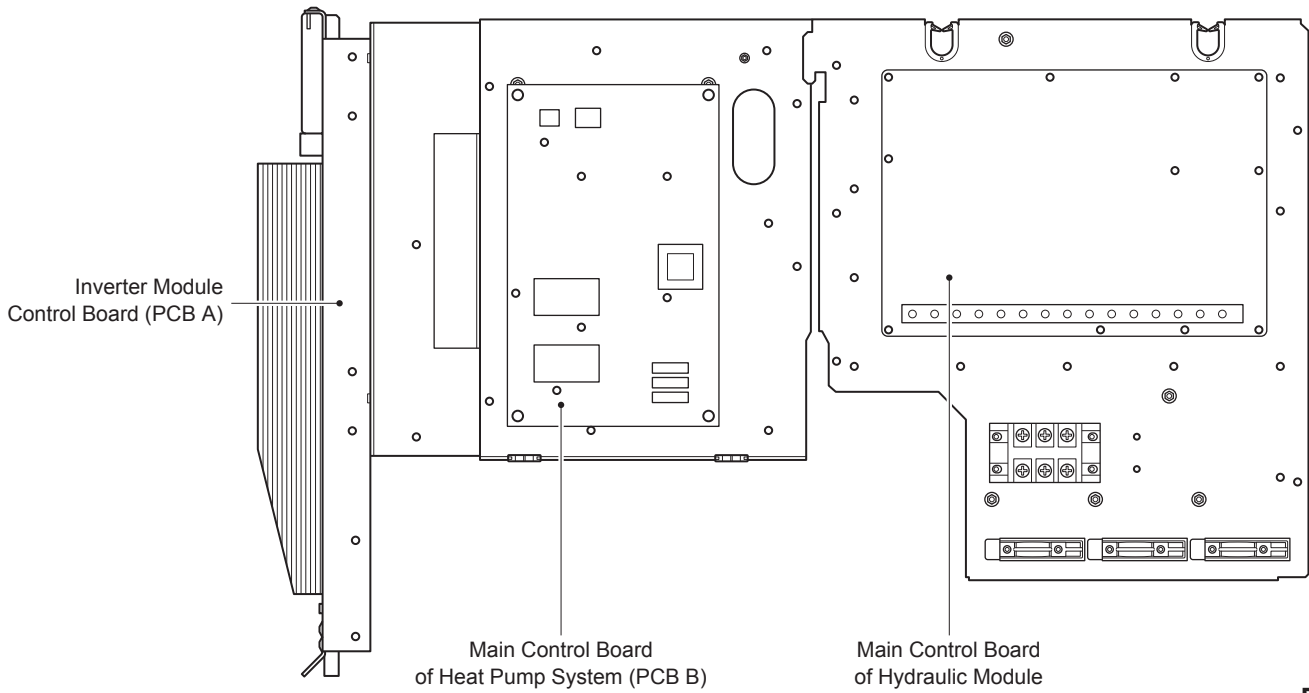

Fig. 24

11/13kW 1-phase

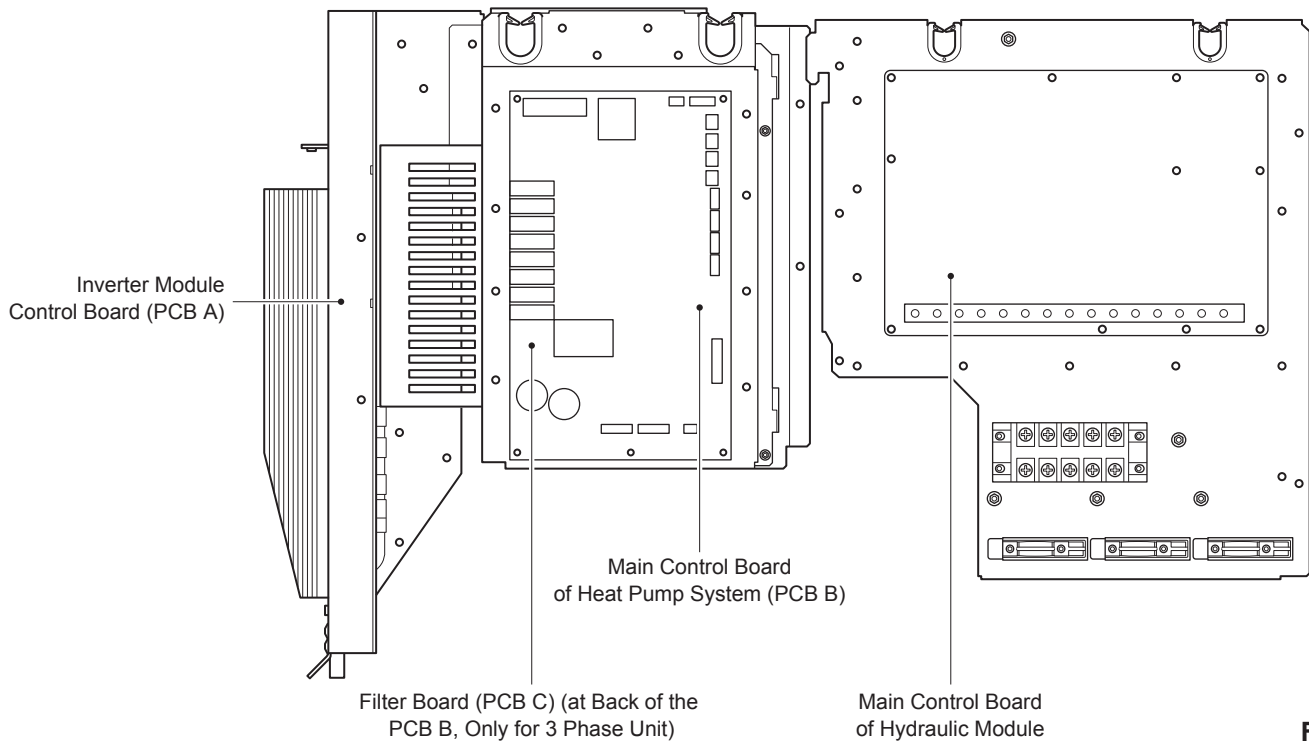

Fig. 25

11/13kW 3-phase

9.3.1 Main control board of hydraulic module

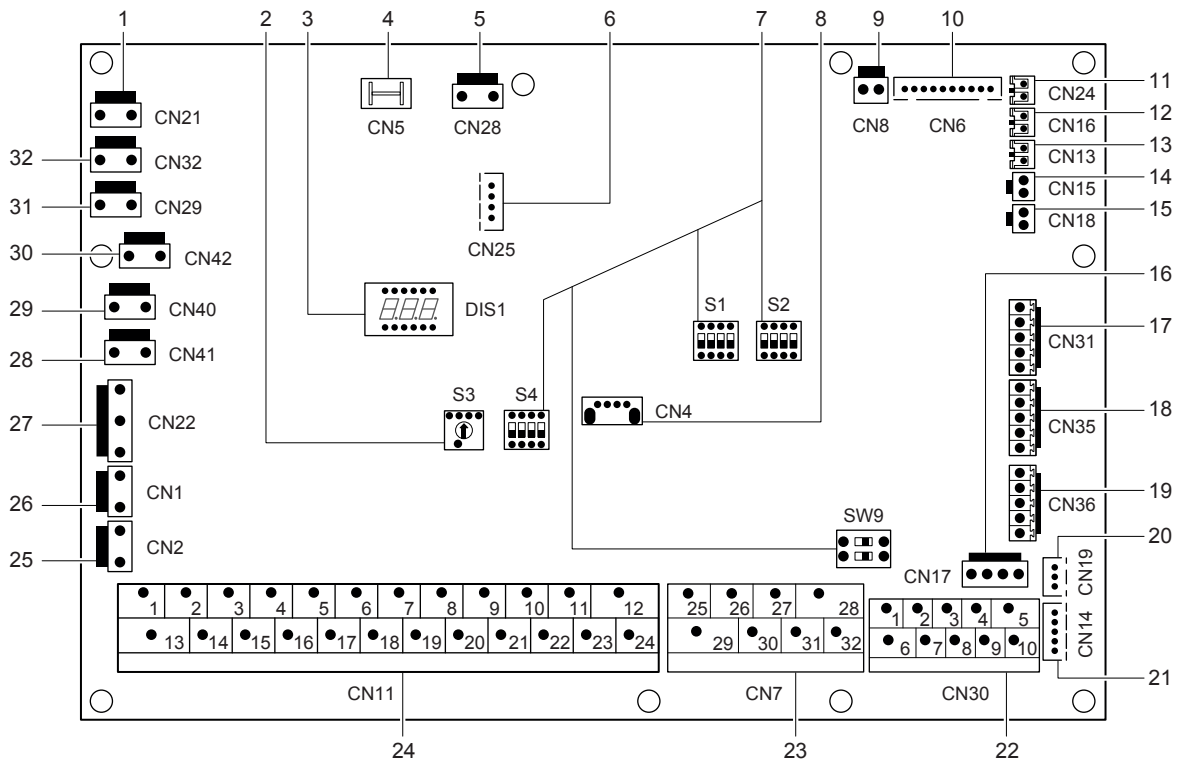

Fig. 26

No.	Port	Code	Assembly unit
1	CN21	POWER	Port for power supply
2	S3	/	Rotary dip switch
3	DIS1	/	Digital display
4	CN5	GND	Port for ground
5	CN28	PUMP	Port for variable speed pump power input
6	CN25	DEBUG	Port for IC programming
7	S1, S2, S4, SW9	/	Dip switch
8	CN4	USB	Port for USB programming
9	CN8	FS	Port for flow switch
10	CN6	T2	Port for temperature sensors of refrigerant liquid side temperature of indoor unit (heating mode)
		T2B	Port for temperature sensors of refrigerant gas side temperature of indoor unit (cooling mode)
		TW_in	Port for temperature sensors of inlet water temperature of plate heat exchanger
		TW_out	Port for temperature sensors of outlet water temperature of plate heat exchanger
		T1	Port for temperature sensors of final outlet water temperature of indoor unit
11	CN24	Tbt1	Port for upper temperature sensor of buffer tank
12	CN16	Tbt2	Port for lower temperature sensor of buffertank (for optional)
13	CN13	T5	Port for domestic hot water tank temp. sensor
14	CN15	Tw2	Port for outlet water for zone 2 temp. sensor
15	CN18	Tsolar	Port for solar panel temp sensor
16	CN17	Pump_BP	Port for variable speed pump communication
17	CN31	HT	Control port for room thermostat (heating mode)
		COM	Power port for room thermostat
		CL	Control port for room thermostat (cooling mode)
18	CN35	SG	Port for smart grid (grid signal)
		EVU	Port for smart grid (photovoltaic signal)

No.	Port	Code	Assembly unit
19	CN36	M1 M2	Port for remote switch
20	CN19	T1 T2	Port for thermostat transfer board
		PQ	Communication port between indoor unit and outdoor unit
21	CN14	A B X Y E	Communication port for the wired controller
22	CN30	1 2 3 4 5	Communication port for the wired controller
		6 7	Communication port between indoor unit and outdoor unit
		9 10	Port for Internal machine Cascade
		26 30/31 32	Compressor run/Defrost run
23	CN7	25 29	Port for antifreeze E-heating tape(external)
		27 28	Port for additional heat source
24	CN11	1 2	Input port for solar energy
		3 4 15	Port for room thermostat
		5 6 16	Port for SV1 (3-way valve)
		7 8 17	Port for SV2 (3-way valve)
		9 21	Port for zone 2 pump
		10 22	Port for outside circulation pump
		11 23	Port for solar energy pump
		12 24	Port for DHW pipe pump
		13 16	Control port for tank booster heater
		14 17	Control port for internal backup heater 1
18 19 20	Port for SV3 (3-way valve)		
25	CN2	TBH_FB	Feedback port for external temperature switch(shorted in default)
26	CN1	IBH1/2_FB	Feedback port for temperature switch (shorted in default)
27	CN22	IBH1	Control port for internal backup heater 1
		IBH2	Reserved
		TBH	Control port for tank booster heater
28	CN41	HEAT8	Port for anti-freeze electric heating tape (internal)
29	CN40	HEAT7	Port for anti-freeze electric heating tape (internal)
30	CN42	HEAT6	Port for anti-freeze electric heating tape (internal)
31	CN29	HEAT5	Port for anti-freeze electric heating tape (internal)
32	CN32	IBH0	Port for backup heater

9.3.2 1-phase for 4-13kW units

PCB A, 4-8kW Inverter module

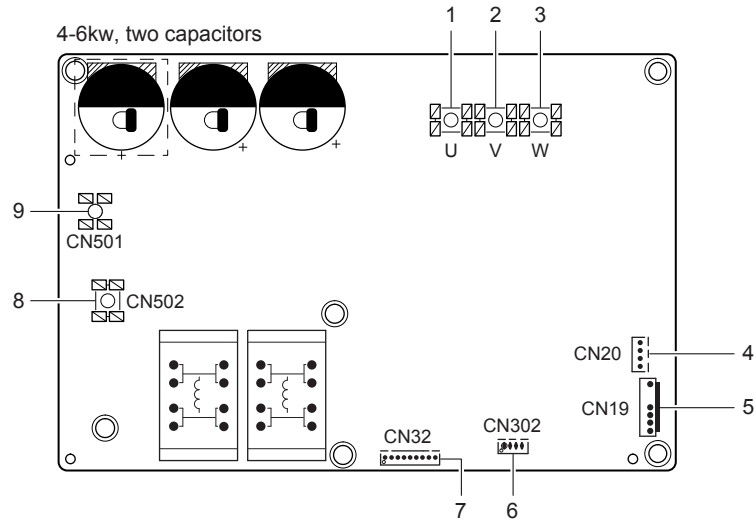

Fig. 27

No.	Port	Assembly unit	No.	Port	Assembly unit
1	U	Compressor connection	6	CN302	Reserved
2	V	Compressor connection	7	CN32	Port for communication with PCB B
3	W	Compressor connection	8	CN502	Input port N for rectifier bridge
4	CN20	Output port for +12V/9V	9	CN501	Input port L for rectifier bridge
5	CN19	Port for fan			

PCB A, 11-13kW Inverter module

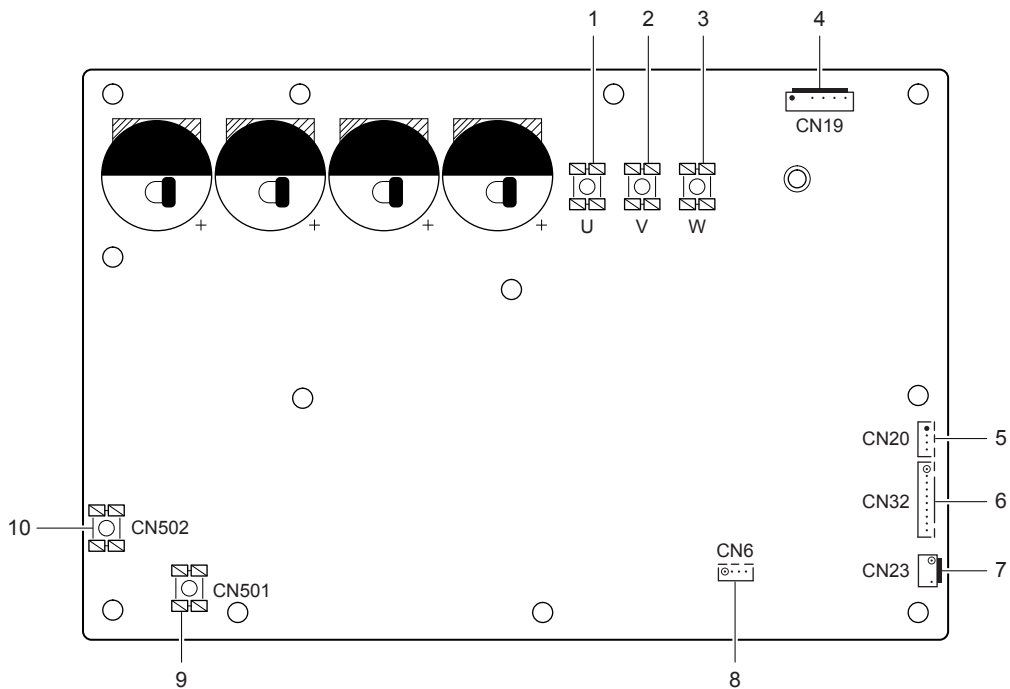

Fig. 28

No.	Port	Assembly unit	No.	Port	Assembly unit
1	U	Compressor connection	6	CN32	Port for communication with PCB B
2	V	Compressor connection	7	CN23	Port for high pressure switch
3	W	Compressor connection	8	CN6	Reserved
4	CN19	Port for fan	9	CN501	Input port L for rectifier bridge
5	CN20	Output port for +12V/9V	10	CN502	Input port N for rectifier bridge

PCB B, Main control board of heat pump system

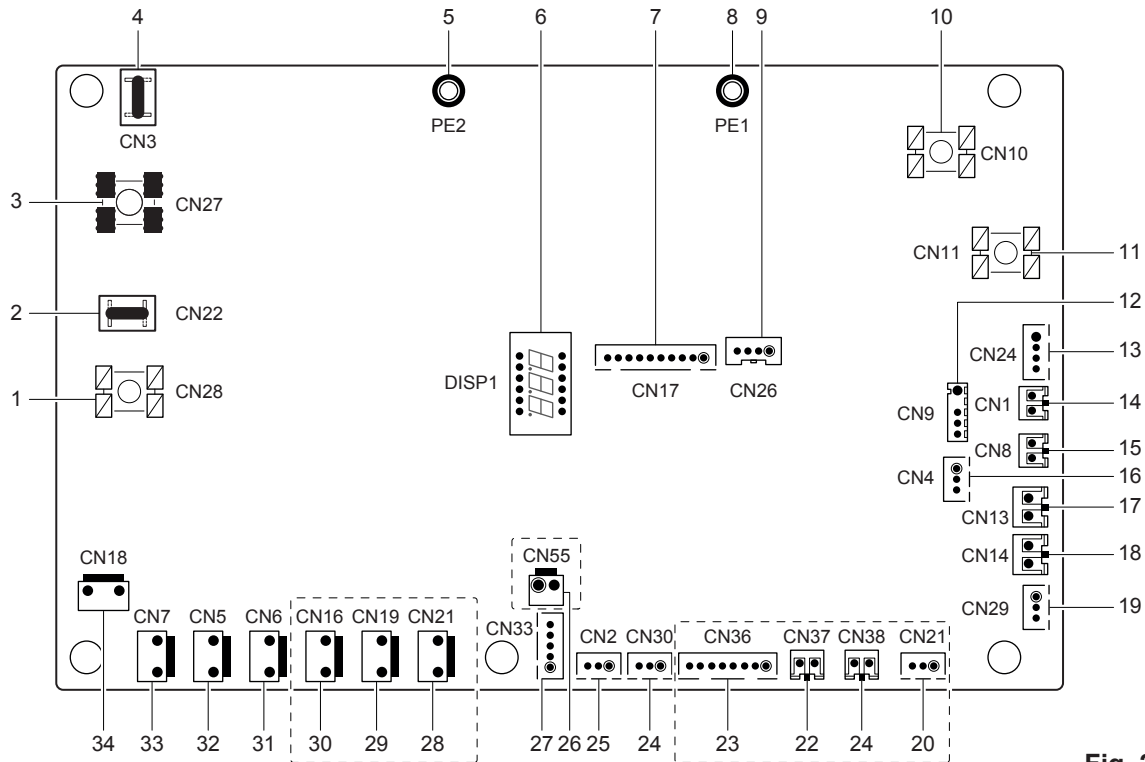

Fig. 29

No.	Port	Assembly unit	No.	Port	Assembly unit
1	CN28	Output port L to PCB A	18	CN14	Port for low pressure switch
2	CN22	Reserved	19	CN29	Port for communication with hydro-box control board
3	CN27	Output port N to PCB A	20	CN20	Reserved
4	CN3	Reserved	21	CN38	Reserved
5	PE2	Port for ground wire	22	CN37	Reserved
6	DISP1	Digital display	23	CN36	Reserved
7	CN17	Port for communication with PCB A	24	CN30	Port for communication (reserved)
8	PE1	Port for ground wire	25	CN2	Port for communication (reserved)
9	CN26	Reserved	26	CN55	Reserved
10	CN10	Input port for neutral wire	27	CN33	Port for electrical expansion valve
11	CN11	Input port for live wire	28	CN21	Reserved
12	CN9	Port for outdoor ambient temp. sensor and condenser temp. sensor	29	CN19	Reserved
13	CN24	Input port for +12V/9V	30	CN16	Port for chassis electrical heating tape (optional)
14	CN1	Port for suction temp. sensor	31	CN6	Port for 4-way valve
15	CN8	Port for discharge temp. sensor	32	CN5	Port for SV6 valve
16	CN4	Port for pressure sensor	33	CN7	Port for compressor electric heating tape 1
17	CN13	Port for high pressure switch	34	CN18	Port for compressor electric heating tape 2

9.3.3 3-phase for 11-13kW units

PCB A, Inverter module

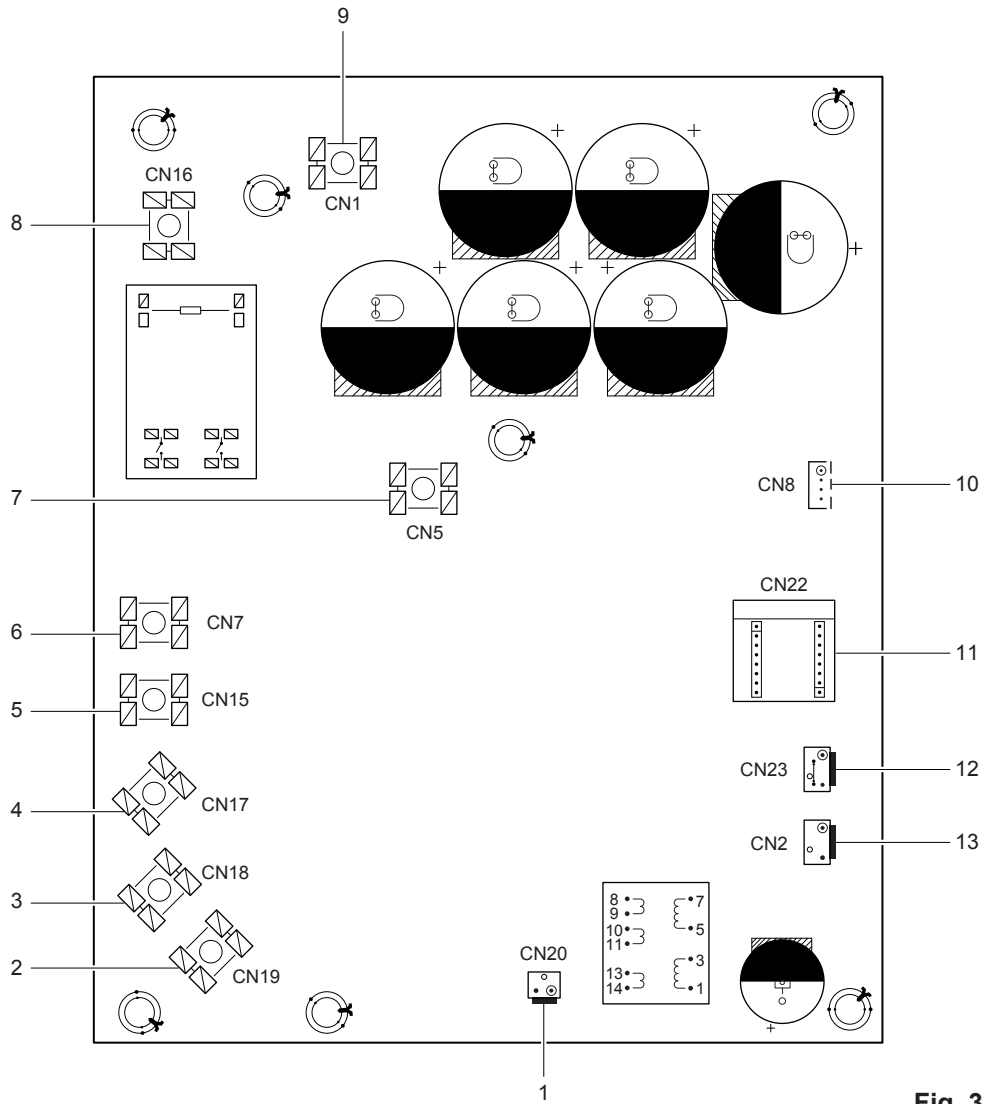

Fig. 30

No.	Port	Assembly unit	No.	Port	Assembly unit
1	CN20	Output port for +15V	8	CN16	Power Input port L1
2	CN19	Compressor connection port W	9	CN1	Input port P_in for IPM module
3	CN18	Compressor connection port V	10	CN8	Port for communication with PCB B
4	CN17	Compressor connection port U	11	CN22	PED board
5	CN15	Power Input port L3	12	CN23	Port for high pressure switch
6	CN7	Power Input port L2	13	CN2	Port for communication with PCB C
7	CN5	Input port P_out for IPM module			

PCB B, Main control board of heat pump system

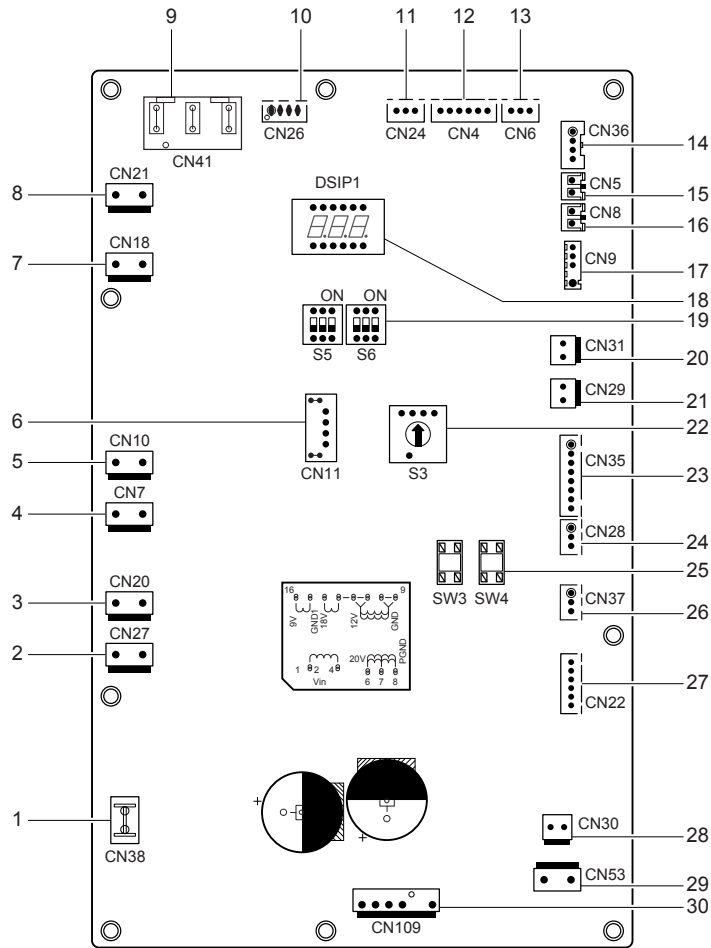

Fig. 31

No.	Port	Assembly unit	No.	Port	Assembly unit
1	CN38	Port for ground wire	16	CN8	Port for temp.sensor Tp
2	CN27	Port for 2-way valve 6	17	CN9	Port for outdoor ambient temp. sensor and condenser temp. sensor
3	CN20	Port for 2-way valve 5	18	DSP1	Digital display
4	CN7	Port for electric heating tape2	19	S5, S6	DIP switch
5	CN10	Port for electric heating tape1	20	CN31	Port for low pressure switch
6	CN11	Reserved	21	CN29	Port for high pressure switch and quick check
7	CN18	Port for 4-way valve	22	S3	Rotary dip switch
8	CN21	Reserved	23	CN35	Port for temp. sensors (TW_out, TW_in, T1, T2, T2B) (reserved)
9	CN41	Power supply port from PCB C	24	CN28	Port for communication XYE
10	CN26	Port for communication with Power Meter	25	S3, S4	Key for force cool & check
11	CN24	Port for communication with hydro-box control board	26	CN37	Port for communication H1 H2E
12	CN4	Port for communication with PCB C	27	CN22	Port for electrical expansion valve
13	CN6	Port for pressure sensor	28	CN30	Port for fan 15V DC power supply
14	CN36	Port for communication with PCB A	29	CN53	Port for fan 310V DC power supply
15	CN5	Port for temp. sensor Th	30	CN109	Port for fan

PCB C, Filter board

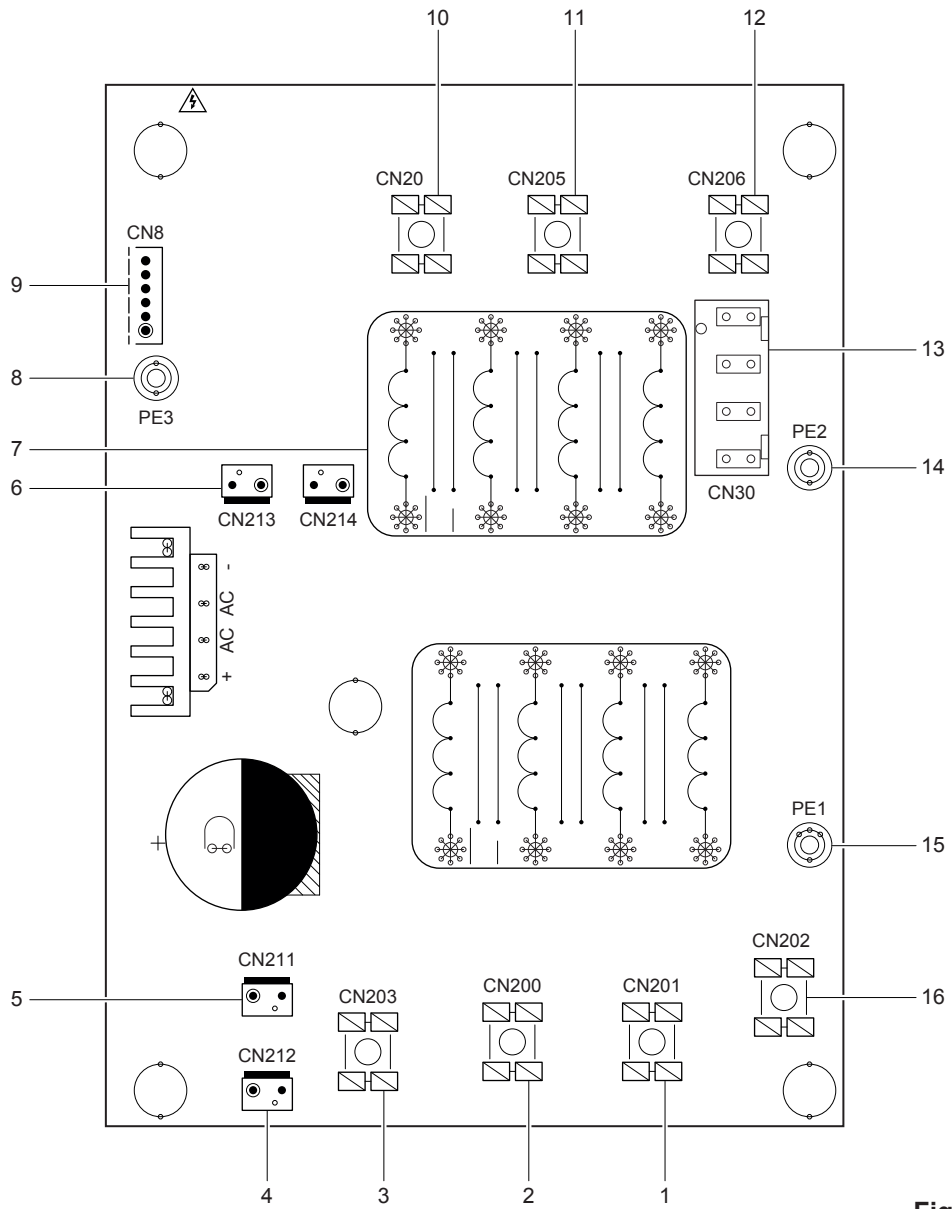
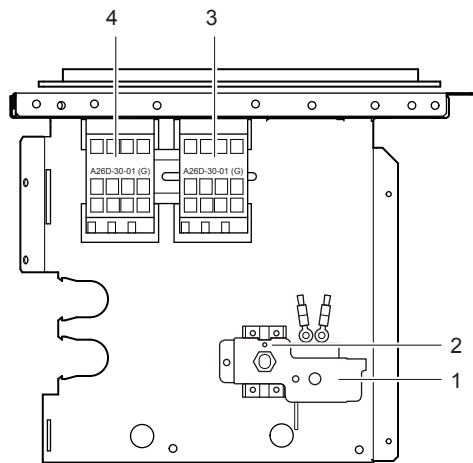

Fig. 32

PCB C 3-phase 11/13kW

No.	Port	Assembly unit	No.	Port	Assembly unit
1	CN201	Power supply L2	9	CN8	Port for communication with PCB B
2	CN200	Power supply L3	10	CN204	Power filtering L3
3	CN203	Power supply N	11	CN205	Power filtering L2
4	CN212	Power supply port of 310VDC	12	CN206	Power filtering L1
5	CN211	Reserved	13	CN30	Power supply port for main control board
6	CN213	Port for FAN Reactor	14	PE2	Port for ground wire
7	CN214	Power supply port for Inverter module	15	PE1	Port for ground wire
8	PE3	Ground wire	16	L1	Power supply L1

9.3.4 Control parts for backup heater (Optional)



1-phase 4/5kW with backup heater (1-phase 3kW)

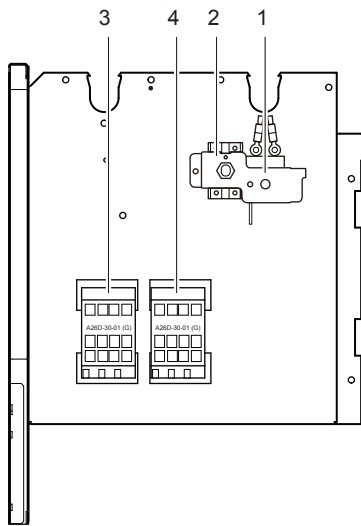

1-phase 7-13kW with backup heater (1-phase 3kW)
3-phase 11-13kW with backup heater (1-phase 3kW)

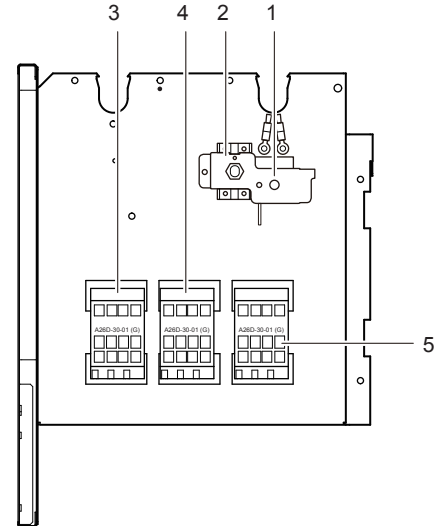

1-phase 7-13kW with backup heater (3-phase 3 or 4.5kW)
3-phase 11-13kW with backup heater (3-phase 3 or 4.5kW)

Fig. 33

No.	Assembly unit	No.	Assembly unit
1	Auto thermal protector	4	Backup heater contactor KM2
2	Manual thermal protector	5	Backup heater contactor KM3
3	Backup heater contactor KM1		

9.4 Water piping

All piping lengths and distances have been taken into consideration.

Requirements

The maximum allowed thermistor cable length is 10m. This is the maximum allowable distance between the domestic hot water tank and the unit (only for installations with a domestic hot water tank).

The thermistor cable supplied with the domestic hot water tank is 10m in length.

In order to optimize efficiency we recommend installing the 3-way valve and the domestic hot water tank as close as possible to the unit.

NOTE

If the installation is equipped with a domestic hot water tank (field supply), please refer to the domestic hot water tank manual. If there is no glycol (anti-freeze) in the system and there is a power supply or pump failure, drain the system (Fig. 34).

9.4.1 Check the water circuit

The unit is equipped with a water inlet and water outlet for connection to a water circuit. This circuit must be provided by a licensed technician and must comply with local laws and regulations.

The unit is only to be used in a closed water system. Application in an open water circuit can lead to excessive corrosion of the water piping.

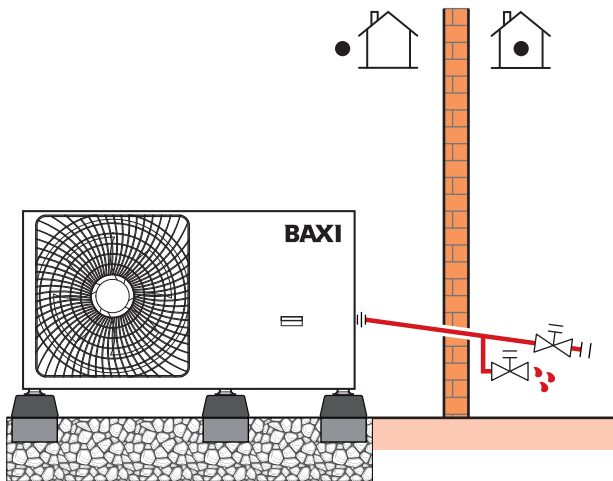

Fig. 34

NOTE

If water is not removed from the system in freezing weather when unit is not used, the frozen water may damage the water circuit parts.

Before continuing the installation of the unit, check the following:

- The maximum water pressure < 3 bar (0.3 MPa).
- The maximum water temperature < 65°C according to safety device setting.
- Always use materials that are compatible with the water used in the system and with the materials used in the unit.
- Ensure that components installed in the external piping can withstand the water pressure and temperature.
- Drain taps must be provided at all low points of the system to permit complete drainage of the circuit during maintenance.
- Air vents must be provided at all high points of the system. The vents should be located at points that are easily accessible for service. An automatic air purge valve is provided inside the unit. Check that this air purge valve is not tightened so that automatic release of air in the water circuit is possible.

9.4.2 Water volume and sizing expansion vessels

The units are equipped with an expansion vessel of 8L that has a default pre-pressure of 1.5 bar (0.15 MPa), To assure proper operation of the unit, the pre-pressure of the expansion vessel might need to be adjusted.

- 1) Check that the total water volume in the installation, excluding the internal water volume of the unit, is at least 40L (see 14 Technical specifications).

NOTE

In most applications this minimum water volume will be satisfactory.

In critical processes or in rooms with a high heat load though, extra water volume might be required.

When circulation in each space heating loop is controlled by remotely controlled valves, it is important that this minimum water volume is kept even if all the valves are closed.

- 2) Expansion vessel volume must fit the total water system volume.
- 3) To size the expansion for the heating and cooling circuit, the expansion vessel volume can follow Fig. 36 below:

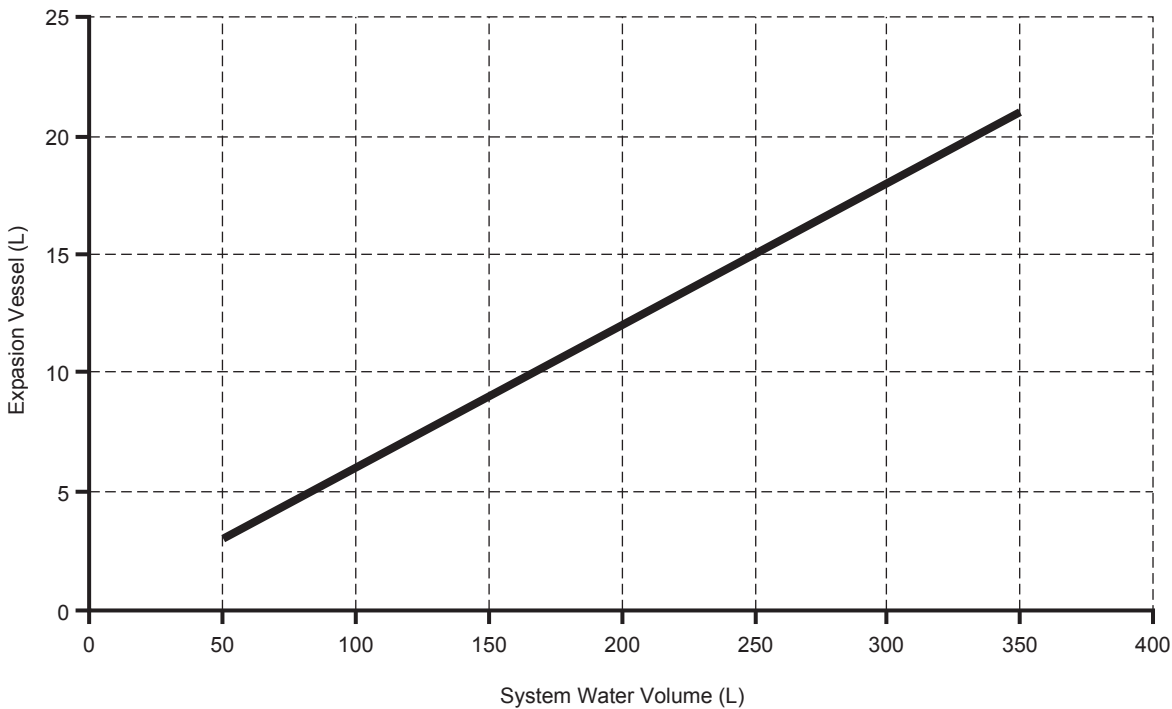

Fig. 36

9.4.3 Water circuit connection

Water connections must be made correctly in accordance with labels on the outdoor unit, with respect to the water inlet and water outlet.

⚠ CAUTION

Be careful not to deform the unit's piping by using excessive force when connecting the piping. Deforming the piping can cause the unit to malfunction.

If air, moisture or dust gets in the water circuit, problems may occur. Therefore, always take into account the following when connecting the water circuit:

- Use clean pipes only.
- Hold the pipe end downwards when removing burrs.
- Cover the pipe end when inserting it through a wall to prevent dust and dirt entering.
- Use a good thread sealant for sealing the connections. The sealing must be able to withstand the pressures and temperatures of the system.
- When using non-copper metallic piping, be sure to insulate two kind of materials from each other to prevent galvanic corrosion.

💡 NOTE

- The unit is only to be used in a closed water system. Application in an open water circuit can lead to excessive corrosion of the water piping:
- Never use Zinc-coated parts in the water circuit. Excessive corrosion of these parts may occur as copper piping is used in the unit's internal water circuit.
- When using a 3-way valve in the water circuit. Preferably choose a ball type 3-way valve to guarantee full separation between the domestic hot water and floor heating water circuit.
- When using a 3-way valve or a 2-way valve in the water circuit. The recommended maximum changeover time of the valve should be less than 60 seconds.

9.4.4 Water circuit anti-freeze protection

All internal hydraulic parts are insulated to reduce heat loss. Insulation must also be added to the external piping.

In event of a power failure, the above features would not protect the unit from freezing.

The software contains special functions using the heat pump and backup heater (if it is available) to protect the entire system against freezing. When the temperature of the water flow in the system drops to a certain value, the unit will heat the water, either using the heat pump, the electric heating tape, or the backup heater. The freeze protection function will turn off only when the temperature increases to a certain value.

Water may enter into the flow switch and cannot be drained out and may freeze when the temperature is low enough. The flow switch should be removed and dried, then can be reinstalled in the unit (Fig. 38).

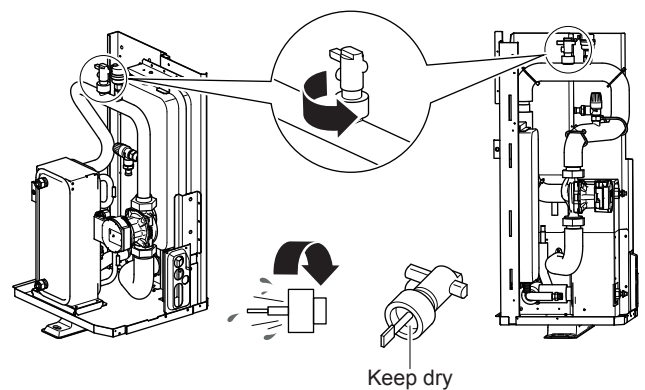

Fig. 38

💡 NOTE

- By rotating in a counterclock manner, remove the flow switch.
- Dry the flow switch completely.

⚠ CAUTION

When the unit is not running for a long time, make sure the unit is powered on all the time. If you want to cut off the power, the water in the system pipe needs to be drained to avoid the unit and pipeline system to be damaged by freezing.

⚠ WARNING

- Glycol can be used to prevent freezing, with a maximum concentration of 30% monopropylene glycol in the unit.
- Propylene Glycol is TOXIC.

9.5 Filling water

- Connect the water supply to the filling valve and open the valve.
- Make sure the automatic air purge valve is open (at least 2 turns).
- Fill with water pressure of approximately 2 bar (0.2 MPa). Remove air in the circuit as much as possible using the air purge valves. Air in the water circuit could lead to malfunction of the optional backup electric heater.

Do not fasten the black plastic cover on the vent valve at the top side of the unit when the system is running. Open air purge valve, turn anticlockwise at least 2 full turns to release air from the system.

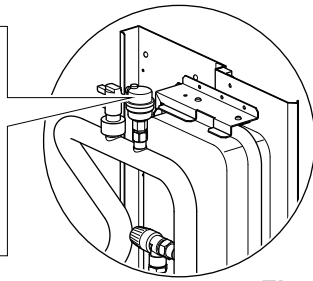

Fig. 39

💡 NOTE

- During filling, it might not be possible to remove all air in the system. Remaining air will be removed through the automatic air purge valves during the first operating hours of the system. Topping up the water afterwards might be required.
- The water pressure will vary depending on the water temperature (higher pressure at higher water temperature). However, at all times water pressure should remain above 0.3 bar (0.03 MPa) to avoid air entering the circuit.
- The unit might drain-off too much water through the pressure relief valve.
- Water quality should be complied with EN 98/83 EC Directives.

9.6 Water piping insulation

The complete water circuit including all piping, must be insulated to prevent condensation during cooling operation and reduction of the heating and cooling capacity as well as prevention of freezing of the outside water piping during winter. The insulation material should at least of B1 fire resistance rating and it should comply with all applicable legislation. The thickness of the sealing materials must be at least 13 mm with thermal conductivity 0.039 W/mK in order to prevent freezing on the outside water piping.

If the outdoor ambient temperature is higher than 30°C and the humidity is higher than RH 80%, then the thickness of the sealing materials should be at least 20 mm in order to avoid condensation on the surface of the seal.

9.7 Field wiring

⚠ WARNING

- A main switch or other means of disconnection, having a contact separation in all poles, must be incorporated in the fixed wiring in accordance with relevant local laws and regulations. Switch off the power supply before making any connections. Use only copper wires. Never squeeze bundled cables and make sure they do not come in contact with the piping and sharp edges. Make sure no external pressure is applied to the terminal connections. All field wiring and components must be installed by a licensed electrician and must comply with relevant local laws and regulations.
- The field wiring must be carried out in accordance with the wiring diagram supplied with the unit and the instructions given below.
- Be sure to use a dedicated power supply. Never use a power supply shared by another appliance.
- Be sure to establish a ground. Do not ground the unit to a utility pipe, surge protector, or telephone ground. Incomplete grounding may cause electrical shock.
- The ground fault circuit interrupter must be a C type breaker of 30 mA (<0.1s). Failure to do so may cause electrical shock.
- Be sure to install the required fuses or circuit breakers.

9.7.1 Precautions on electrical wiring work

- Fix cables so that cables do not make contact with the pipes (especially on the high pressure side).
- Secure the electrical wiring with cable ties so that it does not come in contact with the piping, particularly on the high-pressure side.

- Make sure no external pressure is applied to the terminal connectors.
- When installing the ground fault circuit interrupter make sure that it is compatible with the inverter (resistant to high frequency electrical noise) to avoid unnecessary opening of the ground fault circuit interrupter.

- This unit is equipped with an inverter. Installing a phase advancing capacitor not only will reduce the power factor improvement effect, but also may cause abnormal heating of the capacitor due to high-frequency waves. Never install a phase advancing capacitor as it could lead to an accident.

NOTE

The ground fault circuit interrupter must be a high-speed type breaker of 30 mA (<0.1 s).

9.7.2 Wiring overview

Fig. 40 below gives an overview of the required field wiring between several parts of the installation.

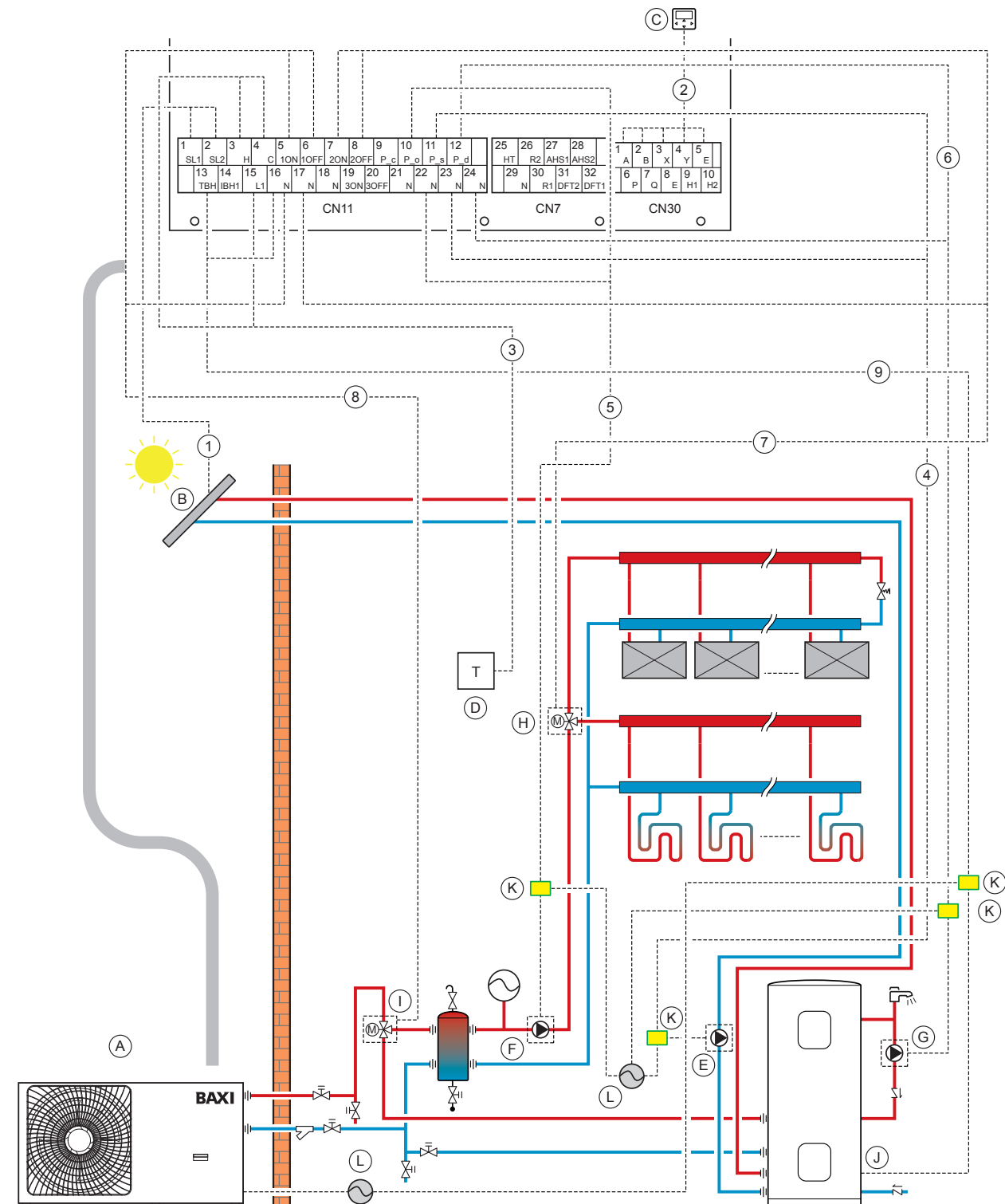

Fig. 40

	Assembly unit		Assembly unit
A	Main unit	G	P_d:DHW pump(field supply)
B	Solar energy kit (field supply)	H	SV2:3-way valve(field supply)
C	User interface	I	SV1:3-way valve for domestic hot water tank(field supply)
D	High voltage room thermostat (field supply)	J	Booster heater
E	P_s: Solar pump (field supply)	K	Contactora
F	P_o: Outside circulation pump (Field supply)	L	Power supply

No.	Description	AC/DC	Required no. of conductors	Maximum running current
1	Solar energy kit signal cable	AC	2	200mA
2	User interface cable	AC	5	200mA
3	Room thermostat cable	AC	2	200mA (a)
4	Solar pump control cable	AC	2	200mA (a)
5	Outside circulation pump control cable	AC	2	200mA (a)
6	DHW pump control cable	AC	2	200mA (a)
7	SV2: 3-way valve control cable	AC	3	200mA (a)
8	SV1: 3-way valve control cable	AC	3	200mA (a)
9	Booster heater control cable	AC	2	200mA (a)

(a) Minimum cable section AWG18 (0.75 mm²).

(b) The thermistor cable is delivered with the unit:
if the current of the load is large, an AC contactor is needed.

NOTE

Please use H07RN-F for the power wire, all the cables are connected to high voltage except for thermistor cable and cable for user interface.

- Equipment must be grounded.

All high-voltage external load, if it is metal or a grounded port, must be grounded.

- All external load current need to be lower than 0.2A, if the single load current is greater than 0.2A, the load must be controlled through AC contactor.
- 'AHS1' 'AHS2', 'A1' 'A2', 'R1' 'R2' and 'DFT1' 'DFT2' wiring terminal ports provide only the switch signal.
- Please refer to the Figs. in 9.7.6 to get the ports position in the unit.
- Expansion valve E-Heating tape, Plate heat exchanger E-Heating tape and Flow switch E-Heating tape share a control port.

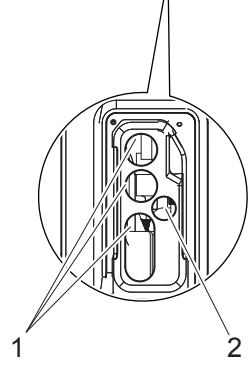
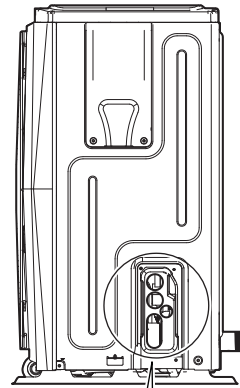
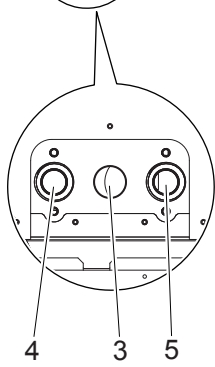
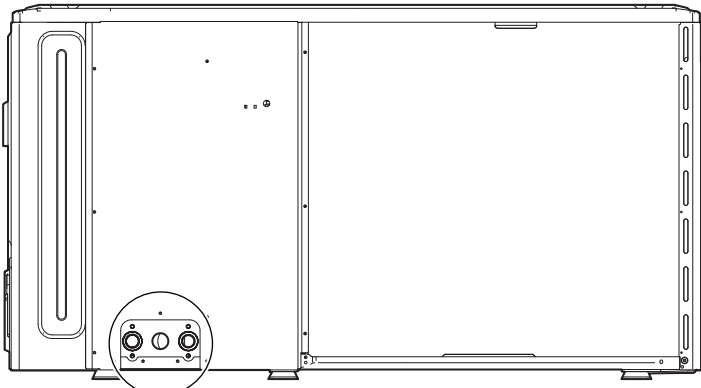

4/5kW

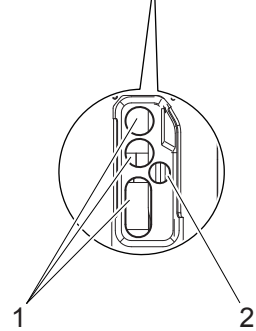
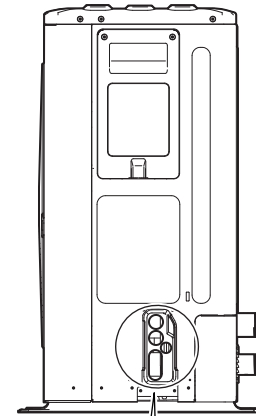
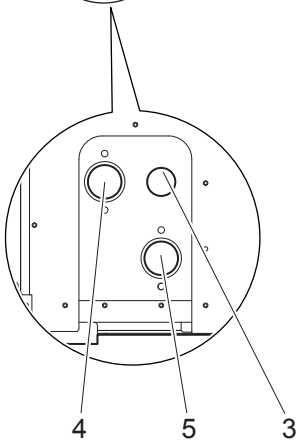
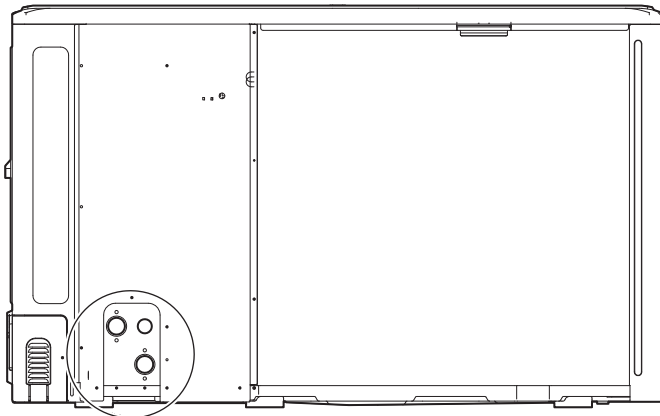

7-13kW

Fig. 41

No.	Assembly unit
1	High voltage wire hole
2	Low voltage wire hole
3	Drainage pipe hole
4	Water outlet
5	Water inlet

Field wiring guidelines

- Most field wiring on the unit has to be connected on the terminal block inside the switch box. To gain access to the terminal block, remove the switch box service panel.

⚠ WARNING

Switch off all power including the unit power supply and backup heater and domestic hot water tank power supply (if applicable) before removing the switch box service panel.

- Fix all cables using cable ties.
- A dedicated power circuit is required for the optional backup heater.
- Installations equipped with a domestic hot water tank (field supply) require a dedicated power circuit for the booster heater. Please refer to the domestic hot water tank manual. Secure the wiring as shown in Fig 42.
- Lay out the electrical wiring so that the front cover does not rise up when doing wiring work and attach the front cover securely.
- Follow the electric wiring diagram for electrical wiring works.
- Install the wires and fix the cover firmly so that the cover fits in properly.

9.7.3 Precautions on wiring of power supply

- Use a round crimp-style terminal for connection to the power supply terminal board. In case it cannot be used due to unavoidable reasons, be sure to observe the following instructions.
- Do not connect different gauge wires to the same power supply terminal. (Loose connections may cause overheating.)
- When connecting wires of the same gauge, connect them according to Fig 42.
- Use the correct screwdriver to tighten the terminal screws. Small screwdrivers can damage the screw head and prevent appropriate tightening.
- Over-tightening the terminal screws can damage the screws.
- Attach a ground fault circuit interrupter and fuse to the power supply line.
- In wiring, make certain that prescribed wires are used, carry out complete connections, and fix the wires so that outside force cannot affect the terminals.

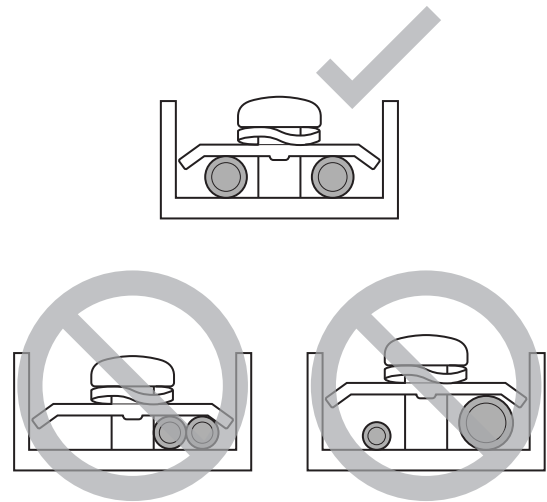

Fig. 42

9.7.4 Safety device requirement

- 1) Select the wire diameters (minimum value) individually for each unit based on the table 9-1 and table 9-2, In case the MCA exceeds 63A, the wire diameters should be selected according to the national wiring regulation.
- 2) Maximum allowable voltage range variation between phases is 2%.
- 3) Select circuit breaker which has a contact separation in all poles not less than 3 mm providing full disconnection, where MFA is used to select the current circuit breakers and residual current operation breakers.

Table 9-1

Rated current of appliance(MCA) (A)	Nominal cross-sectional area (mm ²)	
	Flexible cords	Cable for fixed wiring
< 3	0.5 and 0.75	1 and 2.5
>3 and <6	0.75 and 1	1 and 2.5
>6 and <10	1 and 1.5	1 and 2.5
>10 and <16	1.5 and 2.5	1.5 and 4
>16 and <25	2.5 and 4	2.5 and 6
>25 and <32	4 and 6	4 and 10
>32 and <50	6 and 10	6 and 16
>50 and <63	10 and 16	10 and 25

Table 9-2

1-phase 4-13kW standard and 3-phase 11-13kW standard

Model	Outdoor Unit				Power Current			Compressor		OFM	
	Voltage (V)	Hz	Min. (V)	Max. (V)	MCA (A)	TOCA (A)	MFA (A)	MSC (A)	RLA (A)	KW	FLA (A)
4kW	220-240	50	198	264	12	18	25	-	11.50	0.10	0.50
5kW	220-240	50	198	264	14	18	25	-	13.50	0.10	0.50
7kW	220-240	50	198	264	16	19	25	-	14.50	0.17	1.50
8kW	220-240	50	198	264	17	19	25	-	15.50	0.17	1.50
11kW	220-240	50	198	264	25	30	35	-	23.50	0.17	1.50
13kW	220-240	50	198	264	27	30	35	-	25.50	0.17	1.50
11kW 3-ph	380-415	50	342	456	10	16	14	-	9.50	0.17	1.50
13kW 3-ph	380-415	50	342	456	12	16	14	-	11.15	0.17	1.50

NOTE

MCA : Max. Circuit Amps. (A)
 TOCA : Total Over-current Amps. (A)
 MFA : Max. Fuse Amps. (A)
 MSC : Max. Starting Amps. (A)
 Power (kW): Rated Motor Output
 FLA : Full Load Amps. (A)
 RLA : Rated Load Amps. (A) - in nominal cooling or heating test condition, the input Amps of compressor where Max. Hz can operate

NOTE

The ground fault circuit interrupter must be a C type breaker of 30mA (<0.1s). Please use 3-core shielded wire.

If 3kW or 4.5kW backup heater is needed, please ask professional installer to change the Dip switch.

Stated values are maximum values (see electrical data for exact values).

9.7.5 Remove the switch box cover

1-phase 4-13kW standard and 3-phase 11-13kW standard

Model	4kW	5kW	7kW	8kW	11kW	13kW	11kW 3-ph	13kW 3-ph
Maximum overcurrent protector (MOP) (A)	18	18	19	19	30	30	14	14
Wiring size (mm ²)	4.0	4.0	4.0	4.0	6.0	6.0	2.5	2.5

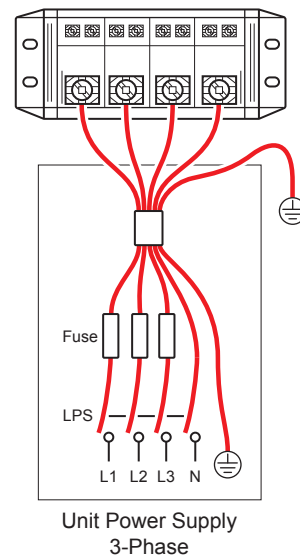
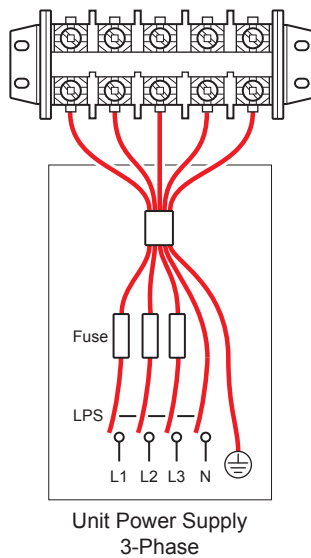
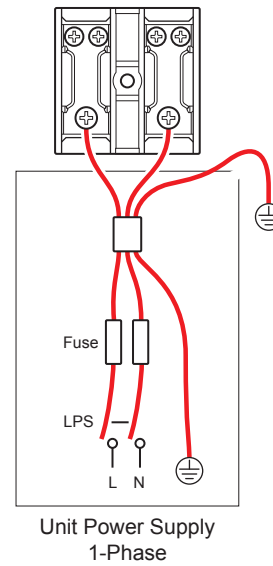
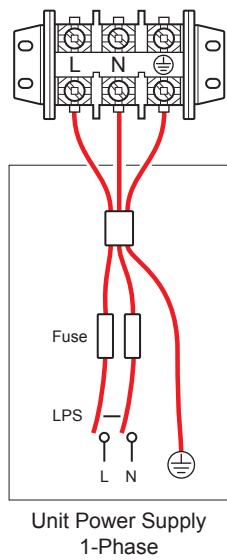

Fig. 43

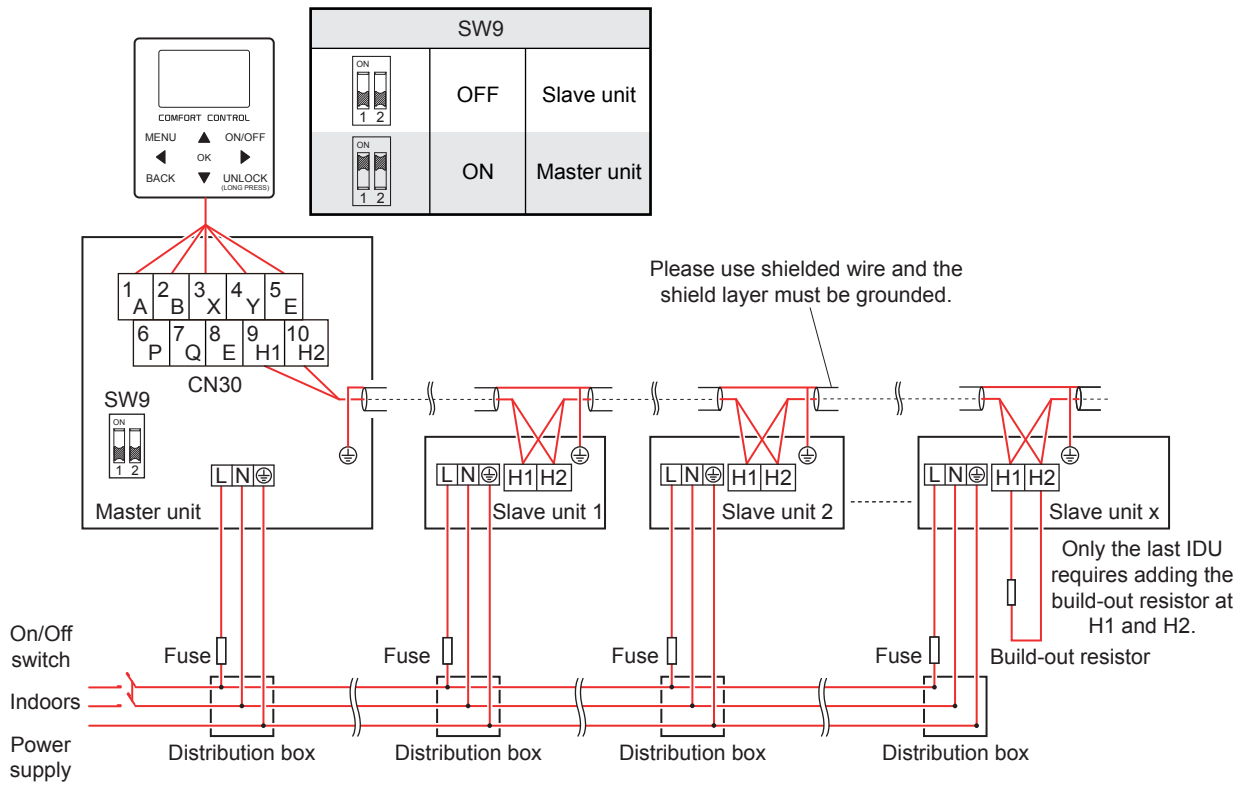

Fig. 44

The cascade system electrical control system connection diagram (1N~)

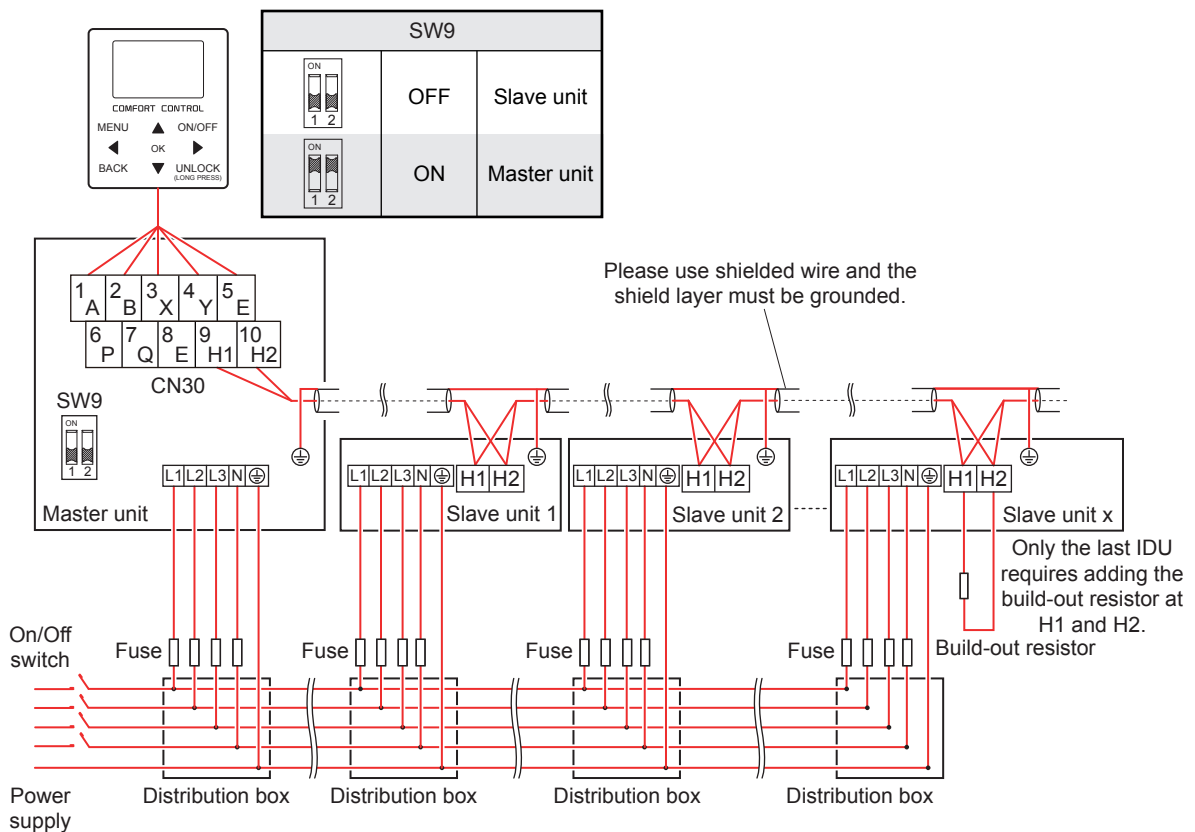

Fig. 45

The cascade system electrical control system connection diagram (3N~)

CAUTION

- 1) The cascade function of the system only supports 6 machines at most.
- 2) In order to ensure the success of automatic addressing, all machines must be connected to the same power supply and powered on uniformly.

- 3) Only the Master unit can connect the controller, and you must put the SW9 to 'on' of the master unit, the slave unit cannot connect the controller.
- 4) Please use the shielded wire, and the shield layer must be grounded.

When connecting to the power supply terminal, use the circular wiring terminal with the insulation casing (Fig. 46).

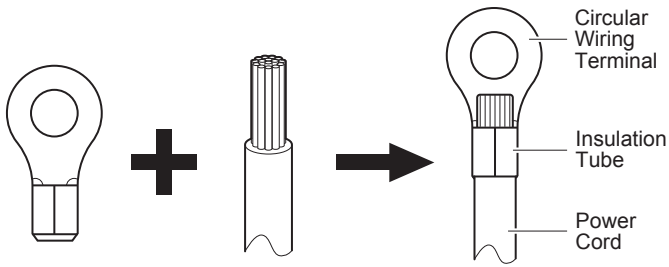

Fig. 46

Use power cord that conforms to the specifications and connect the power cord firmly. To prevent the cord from being pulled out by external force, make sure it is fixed securely.

If circular wiring terminal with the insulation casing cannot be used, make sure to follow this condition:

- Do not connect two power cords with different diameters to the same power supply terminal (may cause overheating of wires due to loose wiring) (Fig. 47).

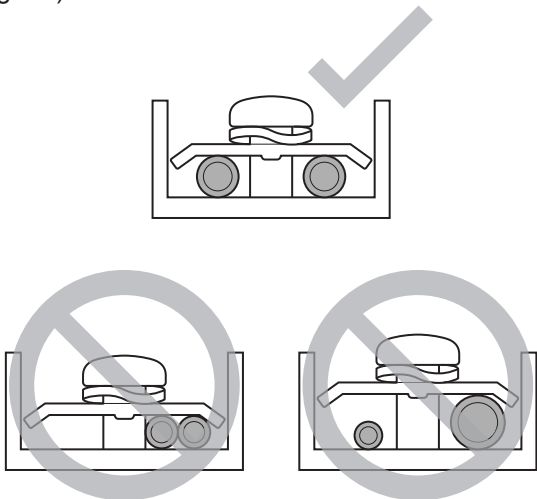

Fig. 47 Power Cord Connection of cascade system

- Use a dedicated power supply for the indoor unit that is different from the power supply for the outdoor unit.
- Use the same power supply, circuit breaker and leakage protective device for the the outdoor units connected to the same indoor unit.

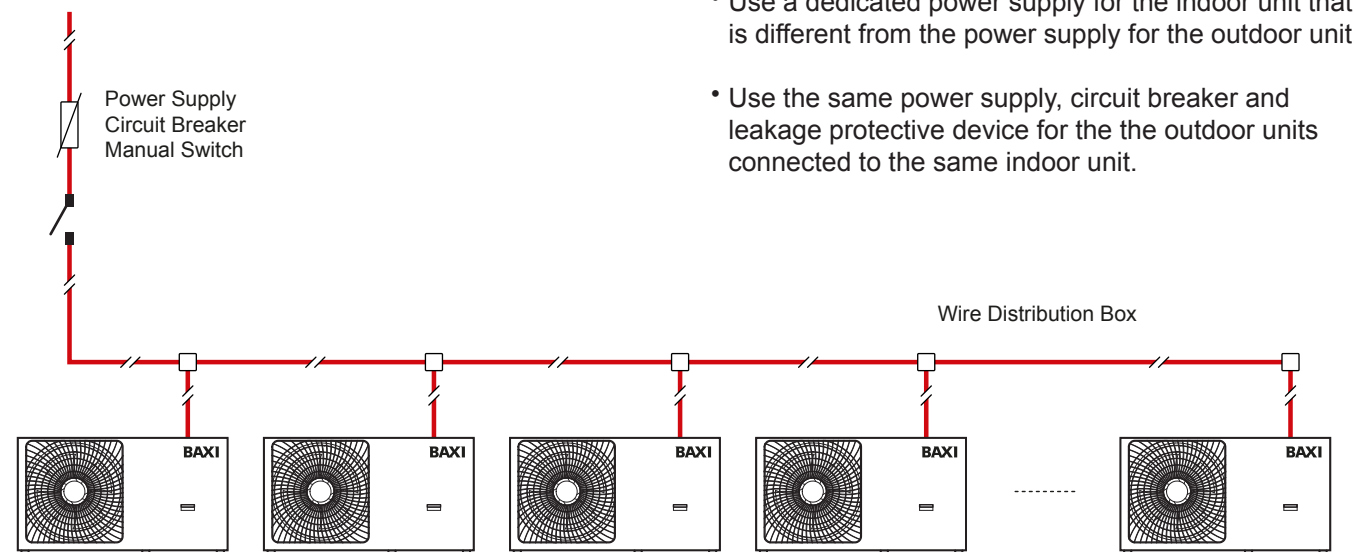

Fig. 48

9.7.6 Connection for other components

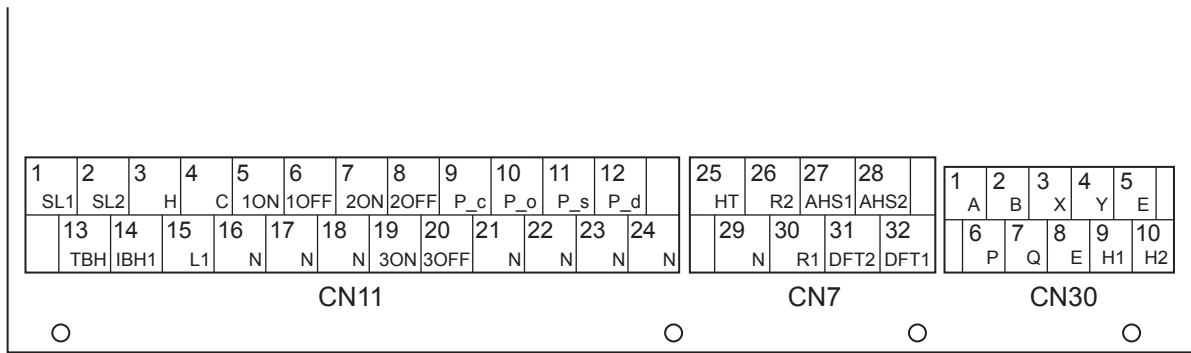

Fig. 49

No.	Print		Connect to
	1	2	
1	1	SL1	Solar energy input signal
	2	SL2	
2	3	H	Room thermostat input (high voltage)
	4	C	
	15	L1	
3	5	1ON	SV1 (3-way valve)
	6	1OFF	
4	7	2ON	SV2(3-way valve)
	8	2OFF	
5	9	P_c	Pump c (zone 2 pump)
	21	N	
6	10	P_o	Outside circulation pump / zone1 pump
	22	N	
7	11	P_s	Solar energy pump
	23	N	
8	12	P_d	DHW pipe pump
	24	N	
9	13	TBH	Tank booster heater
	16	N	
10	14	IBH1	Internal backup heater 1
	17	N	
11	18	N	SV3 (3-way valve)
	19	3ON	
	20	3OFF	

No.	Print		Connect to
	1	2	
1	1	A	Wired controller
	2	B	
	3	X	
	4	Y	
2	5	E	Outdoor unit
	6	P	
3	7	Q	Internal machine cascade
	9	H1	
	10	H2	

No.	Print		Connect to	
	1	2		
1	26	R2	Compressor run	
	30	R1		
	2	31	DFT2	Defrost run
		32	DFT1	
3	25	HT	Antifreeze E-heating tape(external)	
	29	N		
3	27	AHS1	Additional heat source	
	28	AHS2		

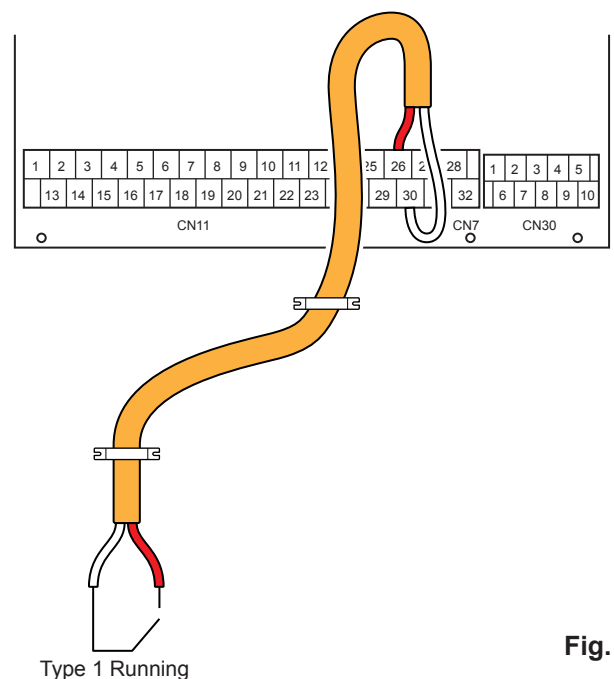

Fig. 50

Port provide the control signal to the load. Two types of control signal port:

- Type 1: Dry connector without voltage.
- Type 2: Port provide the signal with 220V voltage. If the current of load is $<0.2A$, load can connect to the port directly.

If the current of load is $\geq 0.2A$, the AC contactor is required to be connected for the load.

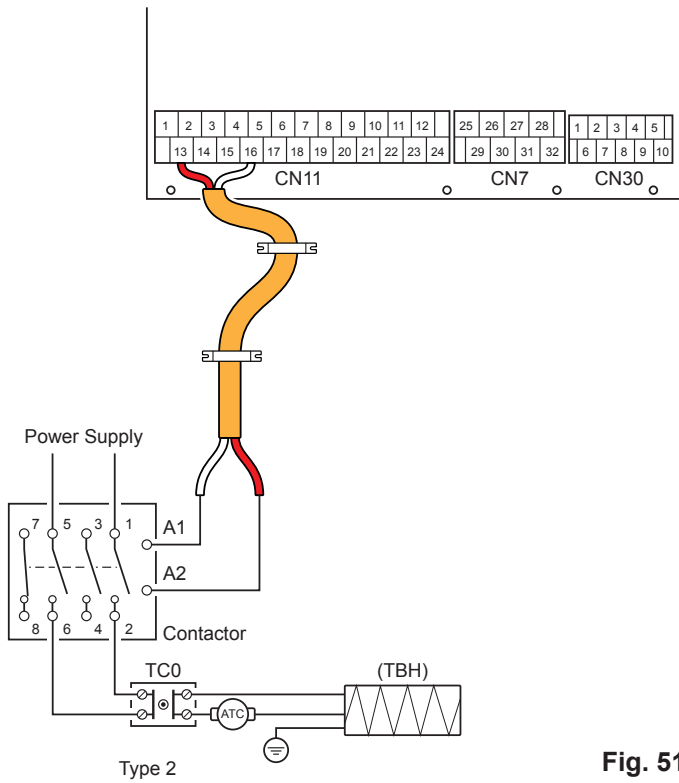

Fig. 51

Control signal port of hydraulic module: The CN11/ CN7 contains terminals for solar energy, 3-way valve, pump, booster heater, etc.

The parts wiring is illustrated below:

1) For solar energy input signal.

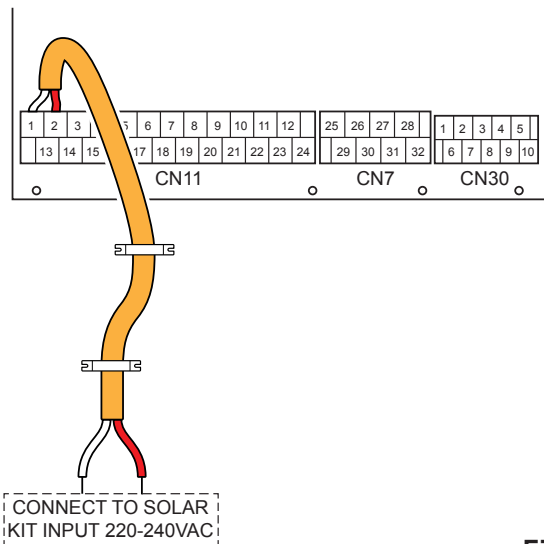

Fig. 52

Voltage	220-240VAC
Maximum running current (A)	0.2
Wiring size (mm ²)	0.75

2) For 3-way valve SV1, SV2 and SV3.

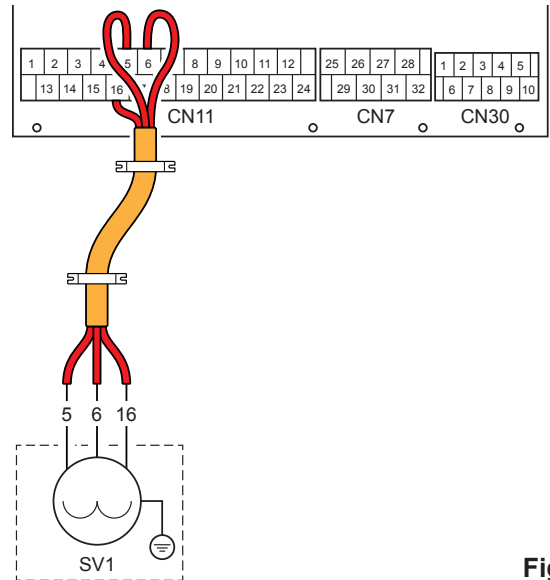

Fig. 53

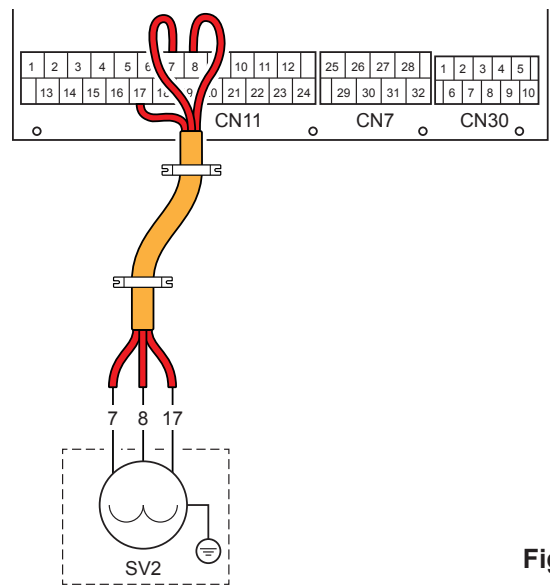

Fig. 54

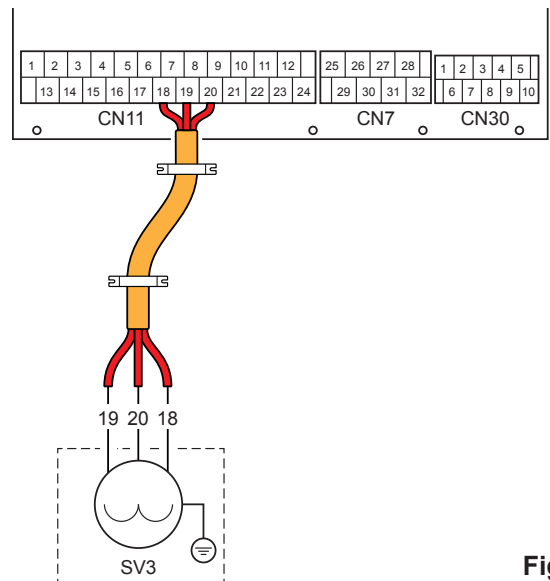

Fig. 55

Voltage	220-240VAC
Maximum running current (A)	0.2
Wiring size (mm ²)	0.75
Control port signal type	Type 2

a) Procedure.

- Connect the cable to the appropriate terminals as shown in Fig. 53-55.
- Fix the cable reliably.

3) For remote shut down.

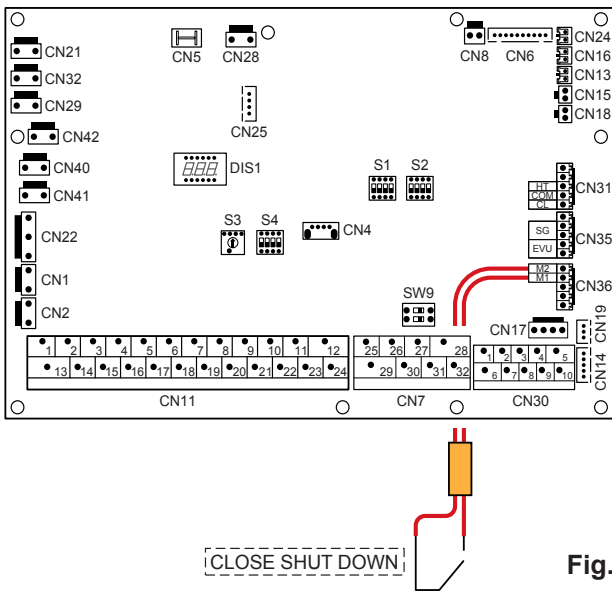

Fig. 56

4) For Pump c and DHW pipe pump.

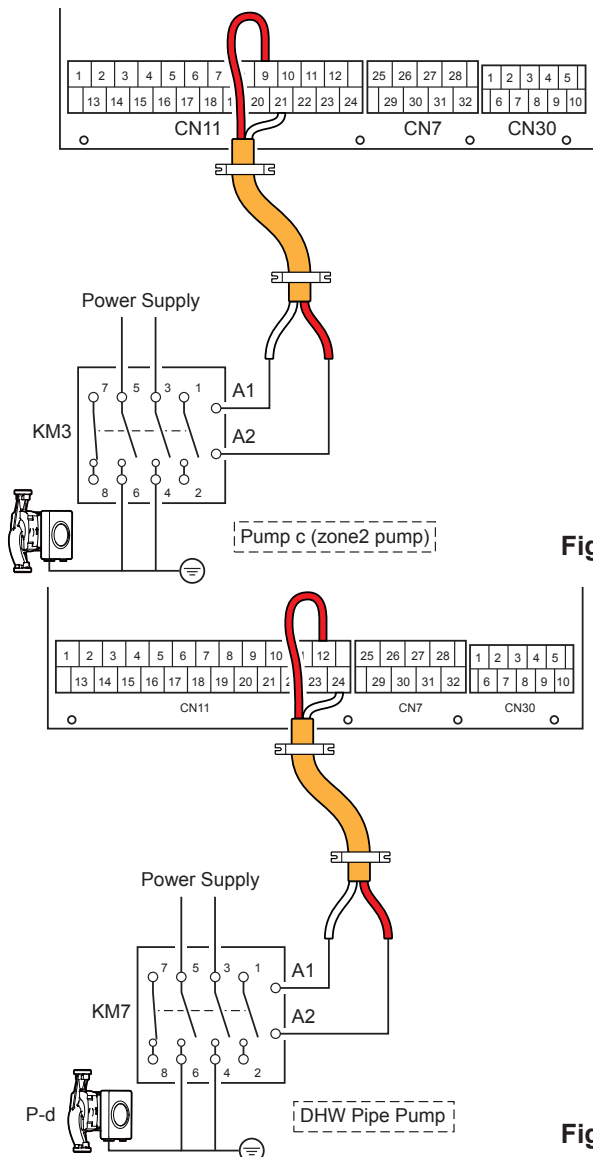

Fig. 57

Fig. 58

Voltage	220-240VAC
Maximum running current (A)	0.2
Wiring size (mm ²)	0.75
Control port signal type	Type 2

a) Procedure.

- Connect the cable to the appropriate terminals as shown in Fig. 57-58.
- Fix the cable reliably.

5) For room thermostat.

Room thermostat type 1 (High voltage): 'POWER IN' provide the working voltage to the RT, does not provide the voltage to the RT connector directly. Port '15 L1' provides the 220V voltage to the RT connector. Port '15 L1' connects from the unit main power supply port L of 1- phase power supply. Room thermostat type 2 (Low voltage) : 'POWER IN' provides the working voltage to the RT.

NOTE

There are two optional connection methods depending on the room thermostat type.

Room thermostat type 1 (High voltage)

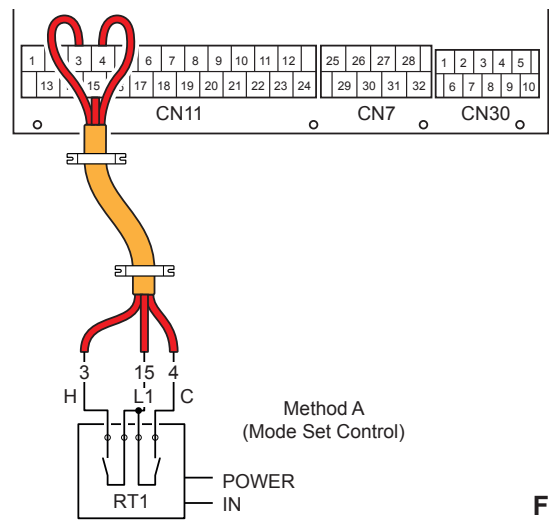

Fig. 59

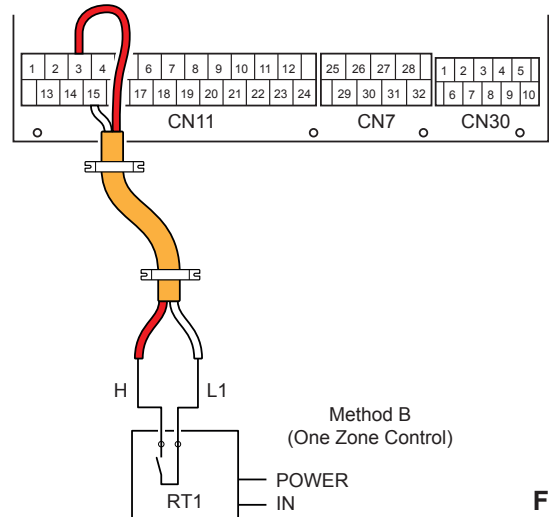

Fig. 60

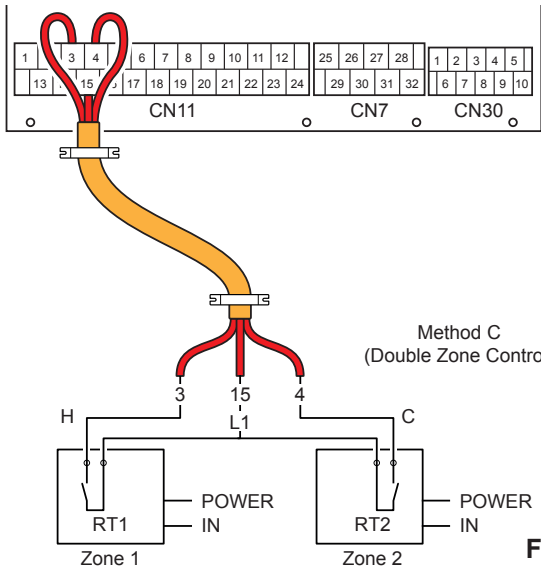

Fig. 61

Voltage	220-240VAC
Maximum running current (A)	0.2
Wiring size (mm ²)	0.75

There are three methods for connecting the thermostat cable (as described in the picture above) and it depends on the application.

Method A (Mode set control)

RT can control heating and cooling individually, like the controller for 4-pipe FCU. When the hydraulic module is connected with the external temperature controller, user interface FOR SERVICEMAN set ROOM THERMOSTAT to MODE SET:

A.1 When unit detects voltage is 230VAC between C and L1, the unit operates in the cooling mode.

A.2 When unit detects voltage is 230VAC between H and L1, the unit operates in the heating mode.

A.3 When unit detects voltage is 0VAC for both side (C-L1, H-L1) the unit stops working for space heating or cooling.

A.4 When unit detects voltage is 230VAC for both side (C-L1, H-L1) the unit is working in cooling mode.

Method B (One zone control)

RT provides the switch signal to unit. User interface FOR SERVICEMAN sets ROOM THERMOSTAT to ONE ZONE:

B.1 When unit detects voltage is 230VAC between H and L1, unit turns on.

B.2 When unit detects voltage is 0VAC between H and L1, unit turns off.

Method C (Double zone control)

Hydraulic Module is connected with two room thermostats, while user interface FOR SERVICEMAN sets ROOM THERMOSTAT to DOUBLE ZONE:

C.1 When unit detects voltage is 230VAC between H and L1, zone 1 turns on. When unit detects voltage is 0VAC between H and L1, zone 1 turns off.

C.2 When unit detects voltage is 230VAC between C and L1, zone 2 turns on according to climate temp curve. When unit detects voltage is 0V between C and L1, zone 2 turns off.

C.3 When H-L1 and C-L1 are detected as 0VAC, unit turns off.

C.4 when H-L1 and C-L1 are detected as 230VAC, both zone 1 and zone 2 turn on.

Room thermostat type 2 (Low voltage)

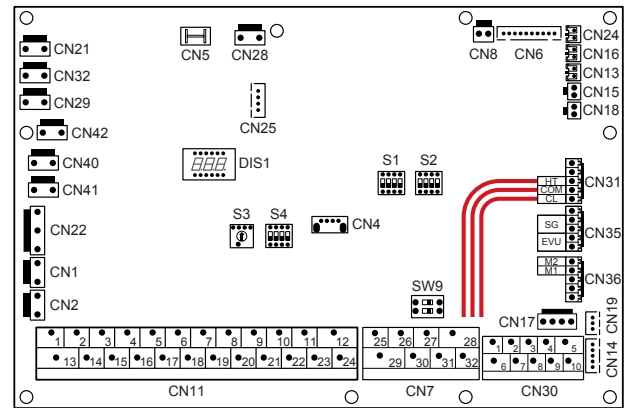

Method A (Mode Set Control)

Fig. 62

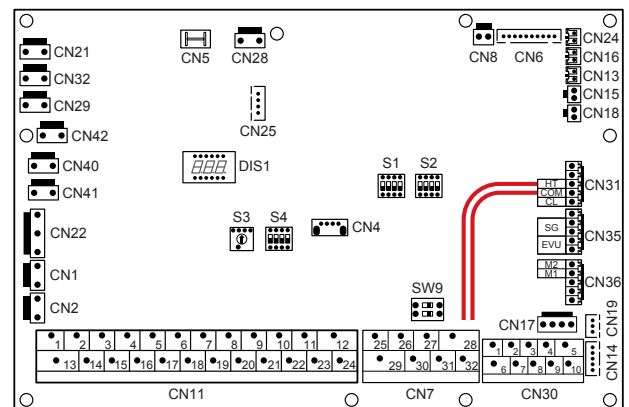

Method B (One Zone Control)

Fig. 63

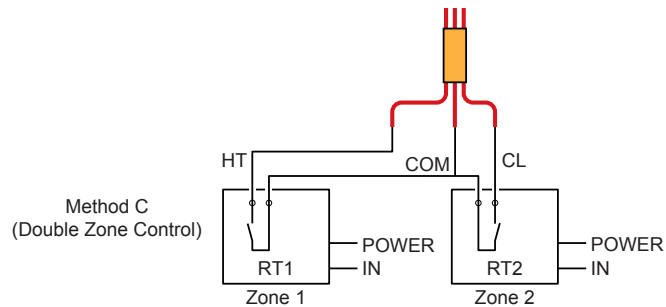
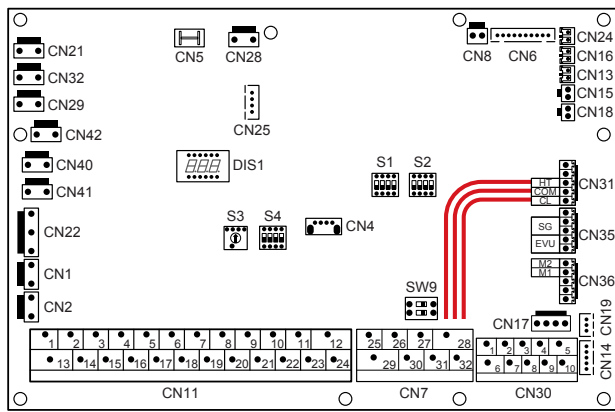

Fig. 64

There are three methods for connecting the thermostat cable (as described in Figs. 62-64) and it depends on the application.

Method A (Mode set control)

RT can control heating and cooling individually, like the controller for 4-pipe FCU. When the hydraulic module is connected with the external temperature controller, user interface FOR SERVICEMAN sets ROOM THERMOSTAT to MODE SET:

A.1 When unit detects voltage is 12VDC between CL and COM, the unit operates in the cooling mode.

A.2 When unit detects voltage is 12VDC between HT and COM, the unit operates in the heating mode.

A.3 When unit detects voltage is 0VDC for both side (CL-COM, HT-COM) the unit stops working for space heating or cooling.

A.4 When unit detects voltage is 12VDC for both side (CL-COM, HT-COM) the unit is working in cooling mode.

Method B (One zone control)

RT provides the switch signal to unit. User interface FOR SERVICEMAN sets ROOM THERMOSTAT to ONE ZONE:

B.1 When unit detects voltage is 12VDC between HT and COM, unit turns on.

B.2 When unit detects voltage is 0VDC between HT and COM, unit turns off.

Method C (Double zone control)

Hydraulic Module is connected with two room thermostats, while user interface FOR SERVICEMAN sets ROOM THERMOSTAT to DOUBLE ZONE:

C.1 When unit detects voltage is 12VDC between HT and COM, zone 1 turns on. When unit detects voltage is 0VDC between HT and COM, zone1 turns off.

C.2 When unit detects voltage is 12VDC between CL and COM, zone 2 turns on according to climate temp curve. When unit detects voltage is 0V between CL and COM, zone 2 turns off.

C.3 When HT-COM and CL-COM are detected as 0VDC, unit turns off.

C.4 when HT-COM and CL-COM are detected as 12VDC, both zone 1 and zone 2 turn on.

NOTE

- The wiring of the thermostat should correspond to the settings of the user interface (see 10.5.6 Room Thermostat).
- Power supply of machine and room thermostat must be connected to the same Neutral Line.
- When ROOM THERMOSTAT is not set to NON, the indoor temperature sensor Ta cannot be set to valid.
- Zone 1 can only operate in heating mode, When cooling mode is set on user interface and zone 2 is OFF, 'CL' in zone 1 closes, system still keeps 'OFF'. While installation, the wiring of thermostats for zone 1 and zone 2 must be correct.

a) Procedure

- Connect the cable to the appropriate terminals as shown in Fig.64.
- Fix the cable with cable ties to the cable tie mountings to ensure stress relief.

6) For tank booster heater.

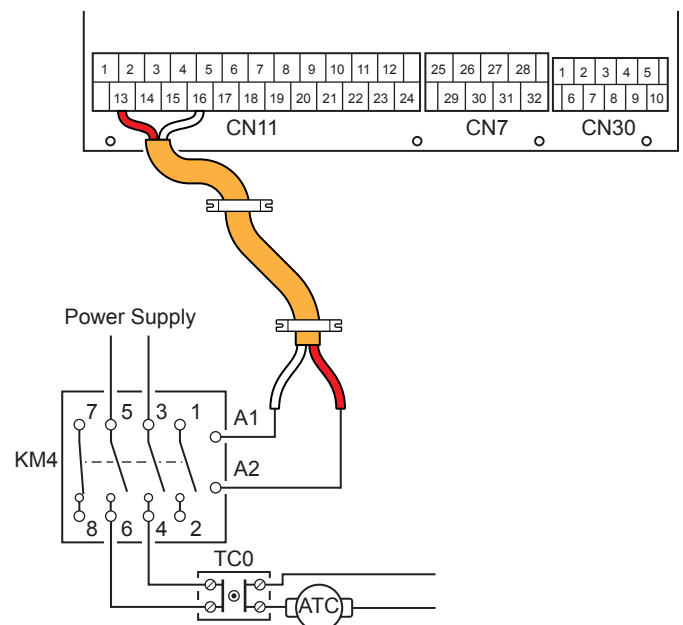

Fig. 65

Voltage	220-240VAC
Maximum running current (A)	0.2
Wiring size (mm ²)	0.75
Control port signal type	Type 2

NOTE
The unit only sends an ON/OFF signal to the heater.

7) For additional heat source control.

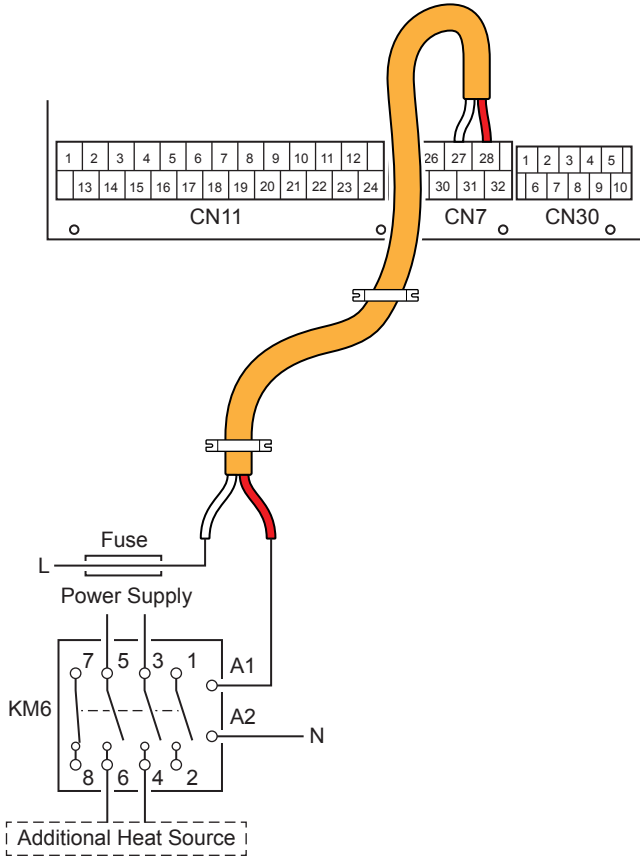
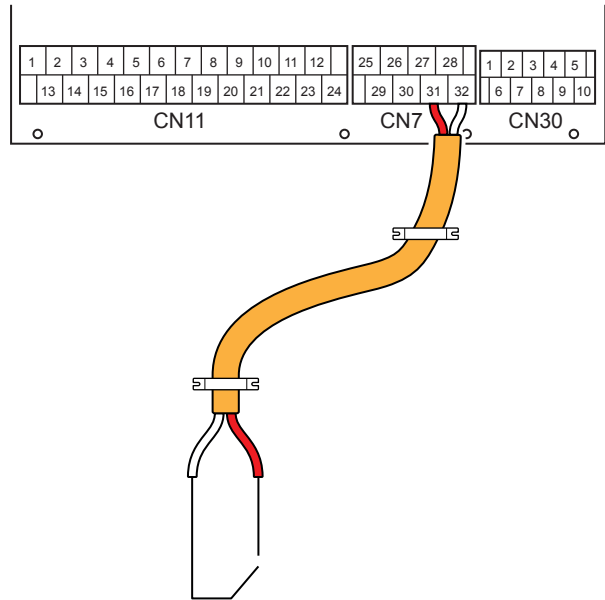

Fig. 66

Voltage	220-240VAC
Maximum running current (A)	0.2
Wiring size (mm ²)	0.75
Control port signal type	Type 2

WARNING
This part only applies to the standard unit, if the unit has an optional backup heater, the hydraulic module should not be connected to any additional heat source.

8) For defrosting signal output.



Defrosting Prompt Signal

Fig. 67

Voltage	220-240VAC
Maximum running current (A)	0.2
Wiring size (mm ²)	0.75
Control port signal type	Type 1

9) For outside circulation pump P_o.

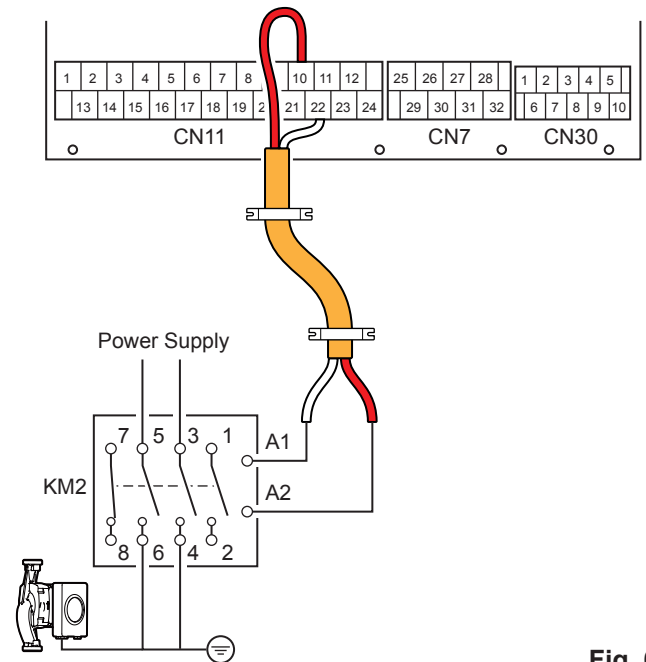

Fig. 68

Voltage	220-240VAC
Maximum running current (A)	0.2
Wiring size (mm ²)	0.75
Control port signal type	Type 2

a) Procedure

- Connect the cable to the appropriate terminals as shown in the picture.
- Fix the cable with cable ties to the cable tie mountings to ensure stress relief.

10) For Smart Grid (installation only).

The unit has smart grid function, there are two ports on PCB to connect for SG and EVU signals as following:

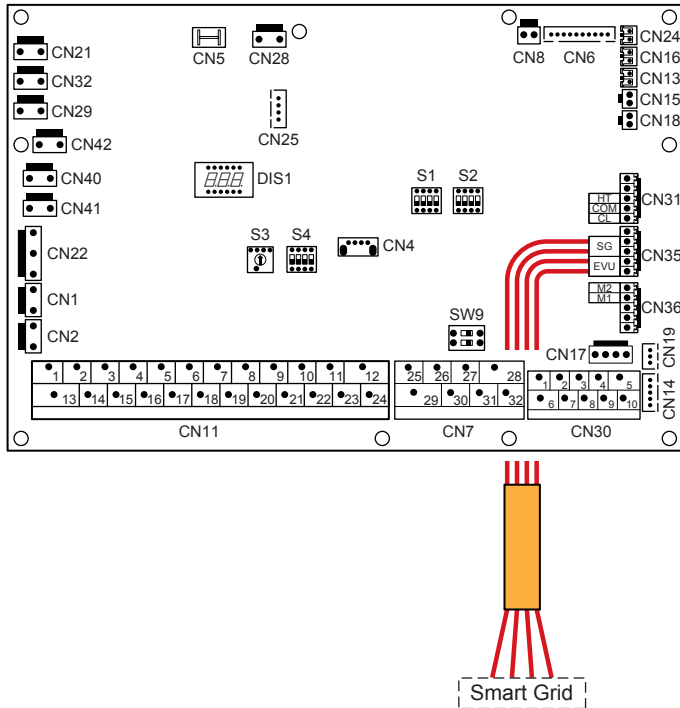

Fig. 69

- 1) When EVU signal is on and SG signal is on, as long as the DHW mode is set to be valid, heat pump will operate DHW mode priority and the DHW mode setting temperature will be changed to 70°C.
 $T5 < 69^{\circ}\text{C}$, the TBH is on, $T5 > 70^{\circ}\text{C}$, the TBH is off.
- 2) When EVU signal is on and SG signal is off, as long as the DHW mode is set to be valid and the mode is on, heat pump will operate DHW mode priority.
 $T5 < T5S-2$ the TBH is on, $T5 > T5S+3$, the TBH is off.
- 3) When EVU signal is off and SG signal is on, the unit operates normally.
- 4) When EVU signal is off and SG signal is off, the unit operates as below: The unit will not operate DHW mode, and the TBH is invalid, disinfect function is invalid. The max running time for cooling / heating is 'SG RUNNING TIME', then unit will be off.

10 Start-up & Configuration

The unit should be configured by the installer to match the installation environment (outdoor climate, installed options, etc.) and user requirements.

⚠ CAUTION

It is important that all information in this chapter is read sequentially by the installer and that the system is configured as applicable.

10.1 DIP switch settings overview

10.1.1 Function setting

DIP switch S1, S2 and S4 are located on the main control hydraulic module board (see 9.3.1 main control board of hydraulic module).

⚠ WARNING

Switch off the power supply before making any changes to the DIP switch settings.

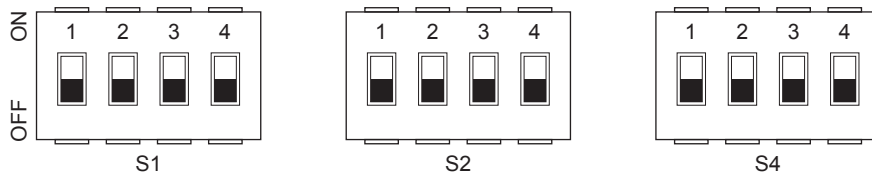

DIP switch S1	ON = 1 OFF = 0	DIP switch S2	ON = 1 OFF = 0	DIP switch S4	ON = 1 OFF = 0
1/2	0/0 = IBH (one-step control)	1	1 = when inactive for 24 hours, pump's blocking function is disabled - it does not run for 1 minute	1	1 = on master unit : clear addresses of all slave units on slave unit: clear its own address
	0/1 = IBH (two-step control)		0 = when inactive for 24 hours, pump's blocking function is enabled - it runs for 1 minute		0 = keep the current address
	1/0 = reserved	2	1 = without TBH	2	1 = IBH for DHW is invalid
	1/1 = IBH (three-step control)		0 = with TBH		0 = IBH for DHW is valid
3/4	0/0 = without IBH and AHS	3	0/0 = reserved (pump with max head 8.5m)	3	0/0 = factory settings
	1/0 = with IBH		0/1 = reserved (pump with constant speed)		0/1 = reserved
	0/1 = with AHS for heat mode		1/0 = reserved (pump with max head 10.5m)		1/0 = reserved
	1/1 = with AHS for heat mode and DHW mode		1/1 = pump 4 (with max head 9.0m)		1/1 = reserved

10.2 Initial start-up at low outdoor ambient temperature

During initial start-up and when water temperature is low, it is important that the water is heated gradually. If the water temperature is below 12°C the heat pump will require an alternative heat source. This will ensure the water temperature is above 12°C. Failure to do so may result in concrete floors cracking due to rapid temperature change. Please contact the responsible cast concrete building contractor for further details.

To do so, the lowest water flow set temperature can be decreased to a value between 25°C and 35°C by adjusting the FOR SERVICEMAN (see 10.5.12 Special function).

10.3 Pre-operation checks

Checks before initial start-up.

DANGER

- Switch off the power supply before making any connections.
- After the installation of the unit, check the following before switching on the circuit breaker:
 - Field wiring: Make sure that the field wiring between the local supply panel and unit and valves (when applicable), unit and room thermostat (when applicable), unit and domestic hot water tank and unit and backup heater kit have been connected according to the instructions (see 9.7 Field wiring), the wiring diagrams and local laws and regulations.
 - Fuses, circuit breakers, or protection devices Check that the fuses or the locally installed protection devices are of the size and type specified (see 14 Technical Specifications). Make sure that no fuses or protection devices have been bypassed.
 - Backup heater circuit breaker: Remember to turn on the backup heater circuit breaker in the switchbox (it depends on the backup heater type). Refer to the wiring diagram.
 - Booster heater circuit breaker: Remember to turn on the booster heater circuit breaker (applies only to units with optional domestic hot water tank installed).
 - Ground wiring: Make sure that the ground wires have been connected properly and that the ground terminals are tightened.
 - Internal wiring: Visually check the switch box for loose connections or damaged electrical components.
 - Mounting: Check that the unit is properly mounted, to avoid abnormal noises and vibrations to start up.

- Damaged equipment: Check the inside of the unit for damaged components or squeezed pipes.
- Refrigerant leak: Check the inside of the unit for refrigerant leakage. If there is a refrigerant leak, call your local competent installer.
- Power supply voltage: Check the power supply voltage on the local supply panel. The voltage must correspond to the voltage on the identification label of the unit.
- Air purge valve: Make sure the air purge valve is open (at least 2 turns).
- Shut-off valves: Make sure that the shut-off valves are fully open.

10.4 The circulation pump

The relationships between the head and the water flow rates, the PMW Return and the water flow rates are shown in Figs. 70-71 below.

(H = height, Q = water flow rate)

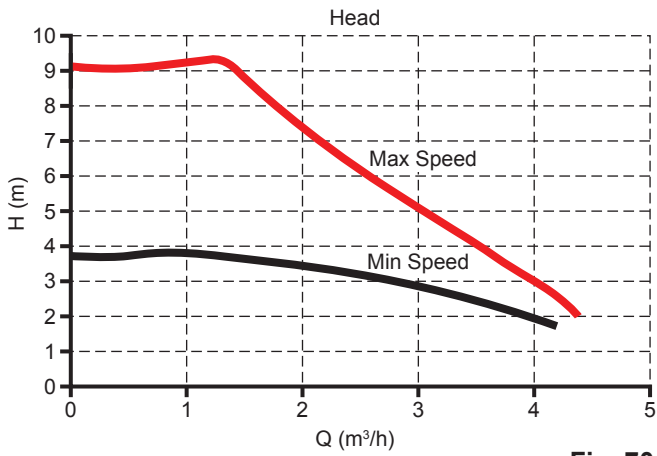

Fig. 70

Area of regulation is included in between the max. speed curve and the min. speed curve.

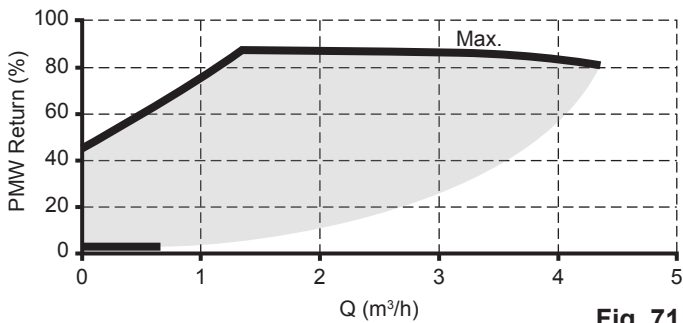

Fig. 71

Available external static pressure (ESP) as a function of water flow rate (Q)

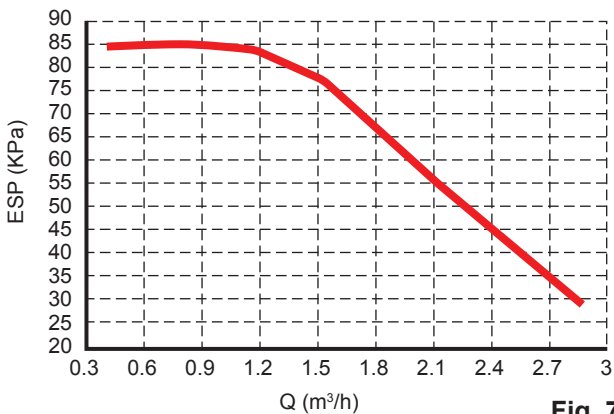
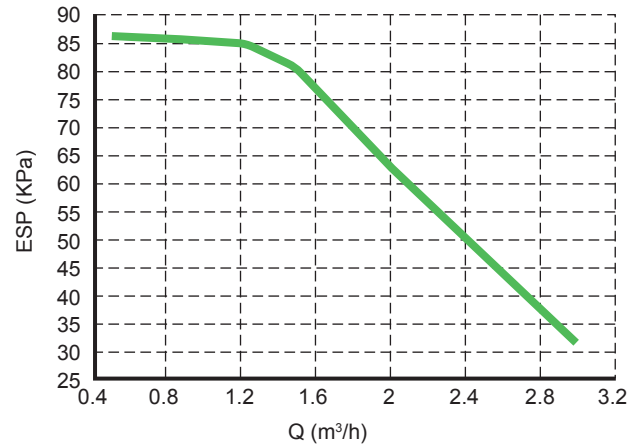

Fig. 72

4/5/7/8kW

Available external static pressure (ESP) as a function of water flow rate (Q)

Available external static pressure (ESP) as a function of water flow rate (Q)



11/13kW

Fig. 73

CAUTION

If the valves are at the incorrect position, the circulation pump will be damaged.

DANGER

If it is necessary to check the running status of the pump when unit power on, please do not touch the internal electronic control box components to avoid electric shock.

Failure diagnosis at first installation

- If nothing is displayed on the user interface, it is necessary to check for any of the following abnormalities before diagnosing possible error codes.
 - Disconnection or wiring error (between power supply and unit and between unit and user interface).
 - The fuse on the PCB may be broken.
- If the user interface shows “E8” or “E0” as an error code, there is a possibility that there is air in the system, or the water level in the system is less than the required minimum.
- If the error code E2 is displayed on the user interface, check the wiring between the user interface and unit. More error codes and failure causes can be found in 13.4 Error codes.

10.5 Field settings

The unit should be configured to match the installation environment (outdoor climate, installed options, etc.) and user requirements. A number of field settings are available. These settings are accessible and programmable through ‘FOR SERVICEMAN’ in user interface.

Powering on the unit

When power on the unit, ‘1%~99%’ is displayed on the user interface during initialization. During this process the user interface cannot be operated.

Procedure

To change one or more field settings, proceed as follows.

NOTE

Temperature values displayed on the wired controller (user interface) are in °C.

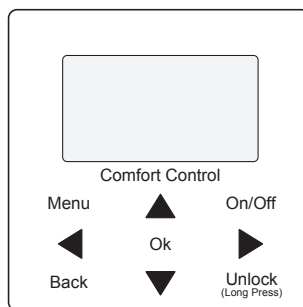

Fig. 74

Keys	Function
Menu	Go to the menu structure (on the home page)
◀▶▲▼	Navigate the cursor on the display Navigate in the menu structure Adjust settings
ON/OFF	Turn on/off the space heating/cooling operation or DHW mode Turn on/off function in the menu structure
BACK	Come back to the up level
UNLOCK	Long press to unlock/lock the controller Unlock/lock some functions such as ‘DHW temperature adjusting’
OK	Go to the next step when programming a schedule in the menu structure; and confirm a selection to enter in the submenu of the menu structure.

About FOR SERVICEMAN

FOR SERVICEMAN is designed for the installer to set the parameters.

- Setting the composition of equipment.
- Setting the parameters.

How to go to FOR SERVICEMAN

Go to MENU> FOR SERVICEMAN. Press OK:

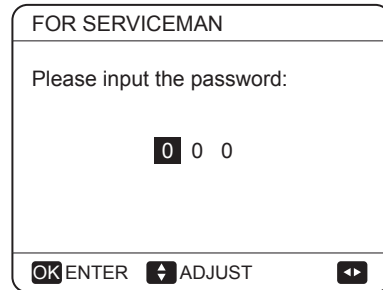

Fig. 75

Press ◀ ▶ to navigate and press ▲ ▼ to adjust the numerical value. Press OK. The password is 234, Figs. 76-78 will be displayed after entering the password:

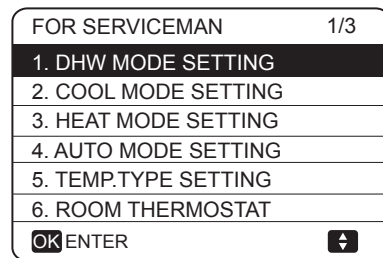

Fig. 76

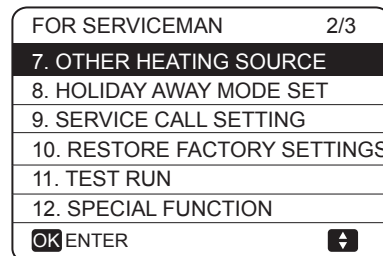

Fig. 77

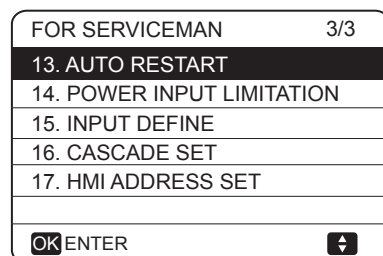

Fig. 78

Press ◀ ▶ to scroll and use ‘OK’ to enter submenu.

10.5.1 DHW MODE SETTING

DHW = domestic hot water

Go to MENU> FOR SERVICEMAN> 1. DHW MODE SETTING. Press OK. Figs. 79-83 will be displayed:

1 DHW MODE SETTING	1/5
1.1 DHW MODE	YES
1.2 DISINFECT	YES
1.3 DHW PRIORITY	YES
1.4 DHW PUMP	YES
1.5 DHW PRIORITY TIME SET	NON
ADJUST	

Fig. 79

1 DHW MODE SETTING	2/5
1.6 dT5_ON	5 °C
1.7 dT1S5	10 °C
1.8 T4DHWMAX	43 °C
1.9 T4DHWMIN	-10 °C
1.10 t_INTERVAL_DHW	5 MIN
ADJUST	

Fig. 80

1 DHW MODE SETTING	3/5
1.11 dT5_TBH_OFF	5 °C
1.12 T4_TBH_ON	5 °C
1.13 t_TBH_DELAY	30 MIN
1.14 T5S_DI	65 °C
1.15 t_DI HIGHTEMP.	15MIN
ADJUST	

Fig. 81

1 DHW MODE SETTING	4/5
1.16 t_DI_MAX	210 MIN
1.17 t_DHWHP_RESTRICT	30 MIN
1.18 t_DHWHP_MAX	120 MIN
1.19 DHWPUMP TIME RUN	YES
1.20 PUMP RUNNING TIME	5 MIN
ADJUST	

Fig. 82

1 DHW MODE SETTING	5/5
1.21 DHW PUMP DI RUN	NON
ADJUST	

Fig. 83

10.5.2 Cool mode setting

Go to MENU> FOR SERVICEMAN> 2. COOL MODE SETTING. Press OK. Figs. 84-86 will be displayed:

2 COOL MODE SETTING	1/3
2.1 COOL MODE	YES
2.2 t_T4_FRESH_C	2.0HRS
2.3 T4CMAX	43 °C
2.4 T4CMIN	20 °C
2.5 dT1SC	5 °C
ADJUST	

Fig. 84

2 COOL MODE SETTING	2/3
2.6 dTSC	2 °C
2.7 t_INTERVAL_C	5MIN
2.8 T1SetC1	10 °C
2.9 T1SetC2	16 °C
2.10 T4C1	35 °C
ADJUST	

Fig. 85

2 COOL MODE SETTING	3/3
2.11 T4C2	25 °C
2.12 ZONE1 C-EMISSION	FCU
2.13 ZONE2 C-EMISSION	FLH
ADJUST	

Fig. 86

10.5.3 Heat mode setting

Go to MENU>FOR SERVICEMAN> 3. HEAT MODE SETTING. Press OK. Figs. 87-89 will be displayed:

3 HEAT MODE SETTING	1/3
3.1 HEAT MODE	YES
3.2 t_T4_FRESH_H	2.0HRS
3.3 T4HMAX	16 °C
3.4 T4HMIN	-15 °C
3.5 dT1SH	5 °C
ADJUST	

Fig. 87

3 HEAT MODE SETTING	2/3
3.6 dTSH	2 °C
3.7 t_INTERVAL_H	5MIN
3.8 T1SetH1	35 °C
3.9 T1SetH2	28 °C
3.10 T4H1	-5 °C
ADJUST	

Fig. 88

3 HEAT MODE SETTING	3/3
3.11 T4H2	7 °C
3.12 ZONE1 H-EMISSION	RAD.
3.13 ZONE2 H-EMISSION	FLH
3.14 t_DELAY_PUMP	2MIN
ADJUST	

Fig. 89

10.5.4 Auto mode setting

Go to MENU> FOR SERVICEMAN> 4. AUTO MODE SETTING. Press OK. Fig. 90 will be displayed.

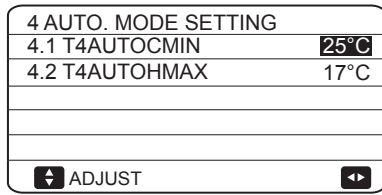
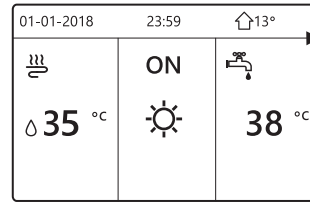
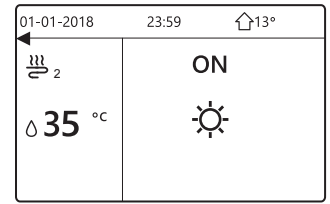

Fig. 90

If you set DOUBLE ZONE to YES and set ROOM TEMP. to NON, irrespective of the WATER FLOW TEMP. setting, Figs 96-97 will be displayed.



Homepage (zone 1)



Additional page (zone 2)

Fig. 96

Fig. 97

In this case, the setting value of zone 1 is T1S, the setting value of zone 2 is T1S2.

If you set DOUBLE ZONE and ROOM TEMP. to YES, irrespective of the WATER FLOW TEMP. setting, Figs. 98-99 will be displayed.

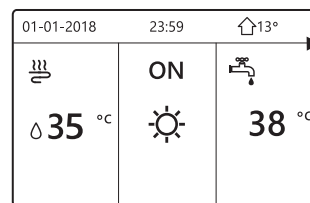

Homepage (zone 1)

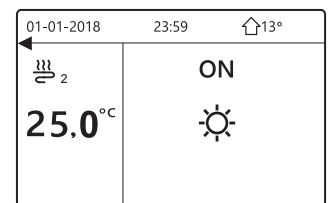

Additional page (zone 2)
(Double zone is effective)

Fig. 98

Fig. 99

In this case, the setting value of zone 1 is T1S, the setting value of zone 2 is T1S2 (The corresponding T1S2 is calculated according to the climate related curves).

10.5.5 Temp. type setting

The TEMP. TYPE SETTING is used for selecting whether the water flow temperature or room temperature is used to control the ON/OFF of the heat pump.

When ROOM TEMP. is enabled, the target water flow temperature will be calculated from climate-related curves.

How to enter the TEMP. TYPE SETTING

Go to MENU> FOR SERVICEMAN> 5. TEMP. TYPE SETTING. Press OK. Fig. 91 will be displayed:

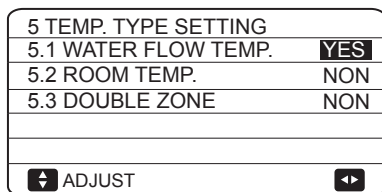
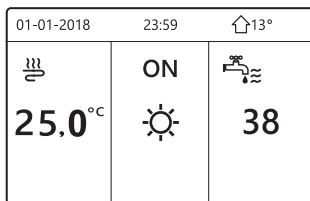

Fig. 91

Set the ROOM TEMP. to YES, Fig. 93 will be displayed.



only ROOM TEMP. YES

Fig. 93

If you set WATER FLOW TEMP. and ROOM TEMP. to YES, irrespective of the DOUBLE ZONE setting, Figs. 94-95 will be displayed.

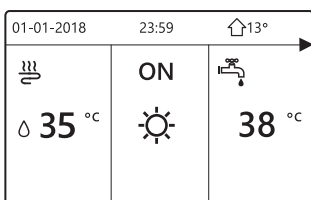

Homepage (zone 1)

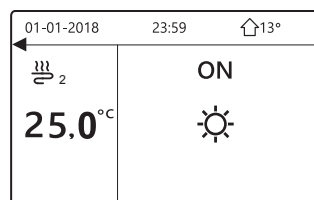

Additional page (zone 2)
(Double zone is effective)

Fig. 94

Fig. 95

In this case, the setting value of zone 1 is T1S, the setting value of zone 2 is T1S2 (The corresponding T1S2 is calculated according to the climate related curves).

10.5.6 Room thermostat

The ROOM THERMOSTAT is used to set whether the room thermostat is available.

How to set the ROOM THERMOSTAT

Go to MENU> FOR SERVICEMAN> 6. ROOM THERMOSTAT. Press OK. Fig.100 will be displayed:

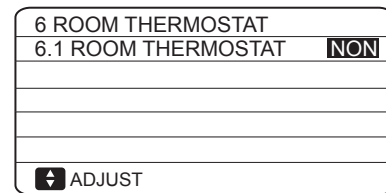

Fig. 100

NOTE

ROOM THERMOSTAT = NON - no room thermostat.

ROOM THERMOSTAT = MODE SET - the wiring of room thermostat should follow method A.

ROOM THERMOSTAT=ONE ZONE - the wiring of room thermostat should follow method B.

ROOM THERMOSTAT=DOUBLE ZONE - the wiring of room thermostat should follow method C (refer to 9.7.6 Connection for other components / For room thermostat).

10.5.7 Other Heating source

The OTHER HEATING SOURCE is used to set the parameters of the backup heater, additional heating sources and solar energy kit.

Go to MENU> FOR SERVICEMAN> 7. OTHER HEATING SOURCE, Press OK. Figs. 101-102 will be displayed.

7 OTHER HEATING SOURCE	1/2
7.1 dt1_IBH_ON	5°C
7.2 t_IBH_DELAY	30MIN
7.3 T4_IBH_ON	-5°C
7.4 dt1_AHS_ON	5°C
7.5 t_AHS_DELAY	30MIN
ADJUST	

Fig. 101

7 OTHER HEATING SOURCE	2/2
7.6 T4_AHS_ON	5°C
7.7 IBH LOCATE	PIPE LOOP
7.8 P_IBH1	0.0kW
7.9 P_IBH2	0.0kW
7.10 P_TBH	2.0kW
ADJUST	

Fig. 102

10.5.8 Holiday away setting

The HOLIDAY AWAY SETTING is used to set the outlet water temperature to prevent freezing when away for holiday.

Go to MENU> FOR SERVICEMAN> 8. HOLIDAY AWAY SETTING. Press OK. Fig.103 will be displayed.

8 HOLIDAY AWAY SETTING	
8.1 T1S_H.A._H	20°C
8.2 T5S_H.A._DHW	20°C
ADJUST	

Fig. 103

10.5.9 Service call setting

The installers can set the phone number of the local supplier in SERVICE CALL SETTING. If the unit does not work properly, call this number for help.

Go to MENU> FOR SERVICEMAN> SERVICE CALL. Press OK. Fig. 104 will be displayed.

9 SERVICE CALL SETTING	
PHONE NO. *****	
MOBILE NO. *****	
OK CONFIRM	ADJUST

Fig. 104

Press ▲ ▼ to scroll and set the phone number. The maximum length of the phone number is 13 digits, if the length of phone number is short than 12, please input ■ , as shown in Fig. 105.

9 SERVICE CALL	
PHONE NO. *****	■■■
MOBILE NO. *****	■
OK CONFIRM	ADJUST

Fig. 105

The number displayed on the user interface is the phone number of your local supplier.

10.5.10 Restore factory settings

The RESTORE FACTORY SETTING is used to restore all the parameters set in the user interface to the factory setting.

Go to MENU> FOR SERVICEMAN> 10. RESTORE FACTORY SETTINGS. Press OK. Fig. 106 will be displayed.

10 RESTORE FACTORY SETTINGS	
All the settings will come back to factory default. Do you want to restore factory settings?	
NO	YES
OK CONFIRM	

Fig. 106

Press ▲ ▼ to scroll the cursor to YES and press OK. Fig. 107 will be displayed.

10 RESTORE FACTORY SETTINGS	
Please wait...	
5%	

Fig. 107

After a few seconds, all the parameters set in the user interface will be restored to factory settings.

10.5.11 Test run

TEST RUN is used to check correct operation of the valves, air purge, circulation pump operation, cooling, heating and domestic water heating.

Go to MENU> FOR SERVICEMAN> 11. TEST RUN. Press OK. Fig. 108 will be displayed.

11 TEST RUN	
Active the settings and active the "TEST RUN"?	
NO	YES
OK CONFIRM	

Fig. 108

If YES is selected, Fig. 109-110 will be displayed.

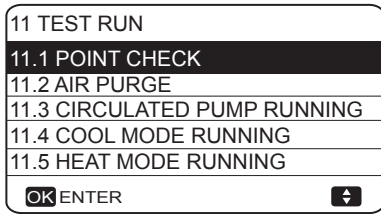

Fig. 109

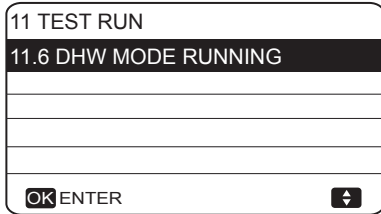

Fig. 110

If POINT CHECK is selected, Fig. 111-112 will be displayed.

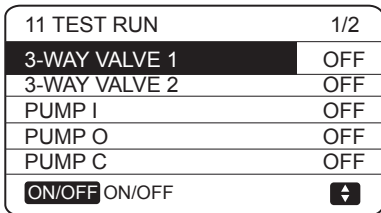

Fig. 111

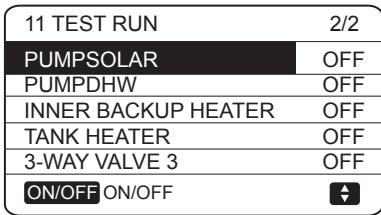

Fig. 112

Press ▲ ▼ to scroll to the components you want to check and press ON/OFF. For example, when 3-way valve is selected and ON/OFF is pressed, if the 3-way valve is open/close, then the operation of 3-way valve is normal, and so are other components.

CAUTION

Before the point check, make sure the tank and the water system is filled with water, and air is expelled, or it may cause the pump or backup heater to burn out.

If you select AIR PURGE and OK is pressed, Fig. 113 will be displayed.

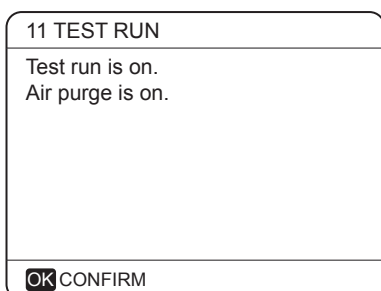

Fig. 113

When in air purge mode, SV1 will open, SV2 will close. 1 minute later the pump in the unit (PUMPI) will operate for 10 minutes during which the flow switch will not work. After the pump stops, the SV1 will close and the SV2 will open. 1 minute later both the PUMPI and PUMPO will operate until the next command is received.

When CIRCULATION PUMP RUNNING is selected, Fig. 114 will be displayed:

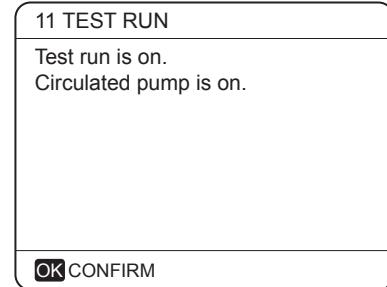

Fig. 114

When circulation pump running is turned on, all running components will stop. 1 minute later, the SV1 will open, the SV2 will close, 1 minute later PUMPI will operate. 30 seconds later, if the flow switch checked normal flow, PUMPI will operate for 3 minutes, after the pump stops for 1 minute, the SV1 will close and the SV2 will open. 1 minute later the both PUMPI and PUMPO will operate, 2 minutes later, the flow switch will check the water flow. If the flow switch closes for 15 seconds, PUMPI and PUMPO will operate until the next command is received.

When the COOL MODE RUNNING is selected, Fig. 115 will be displayed.

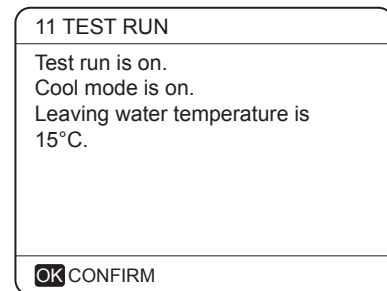

Fig. 115

During COOL MODE test running, the default target outlet water temperature is 7°C. The unit will operate until the water temperature drops to a certain value or the next command is received.

When the HEAT MODE RUNNING is selected, Fig. 116 will be displayed.

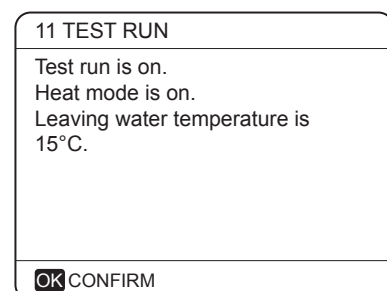

Fig. 116

During HEAT MODE test running, the default target outlet water temperature is 35°C. The IBH (internal backup heater) will turn on after the compressor runs for 10 minutes. This can assist initial start-up in cold conditions. After the IBH runs for 3 minutes, the IBH will turn off, the heat pump will operate until the water temperature increase to a certain value or the next command is received.

When the DHW MODE RUNNING is selected, Fig. 117 will be displayed.

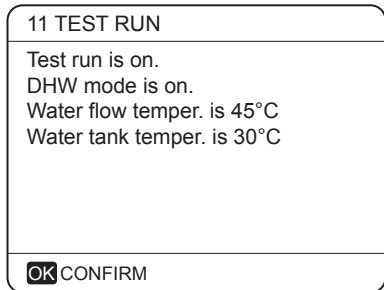

Fig. 117

During DHW MODE test running, the default target temperature of the domestic water is 55°C. The TBH (tank boost heater) will turn on after the compressor runs for 10 minutes. The TBH will turn off 3 minutes later, the heat pump will operate until the water temperature increase to a certain value or the next command is received.

During test run, all buttons except OK are invalid. To turn off the test run, please press OK. For example, when the unit is in air purge mode, after you press OK, Fig. 118 will be displayed.

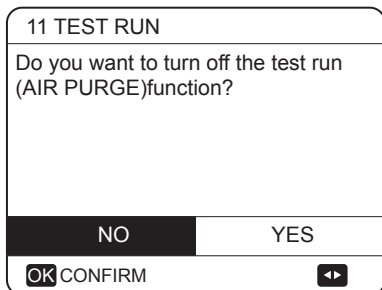

Fig. 118

Press ▲ ▼ to scroll the cursor to YES and press OK. The test run will turn off.

10.5.12 Special function

When it is in special function modes, the wired controller can not operate, the page does not return to the homepage, and the screen will show that special function runs. The wired controller is not locked.

NOTE

During special function operating other functions (WEEKLY SCHEDULE/ TIMER, HOLIDAY AWAY, HOLIDAY HOME) cannot be used.

Go to MENU> FOR SERVICEMAN> 12. SPECIAL FUNCTION.

Before floor heating, if a large amount of water remains on the floor it may become warped or even ruptured during floor heating operation. In order to protect the floor, drying is necessary with gradual increase in its temperature.

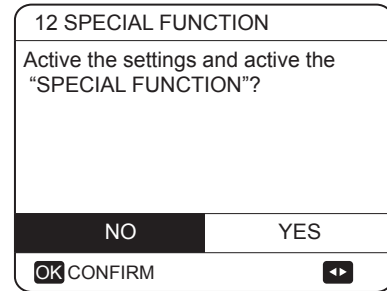

Fig. 119

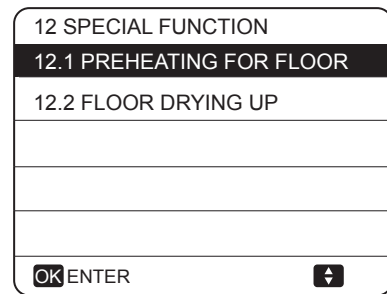

Fig. 120

Press ▲ ▼ to scroll and press OK to enter.

During first operation of the unit, air may remain in the water system which can cause malfunctions during operation. It is necessary to run the air purge function to release the air (make sure the air purge valve is open).

If PREHEATING FOR FLOOR is selected, press OK, Fig. 121 will be displayed.

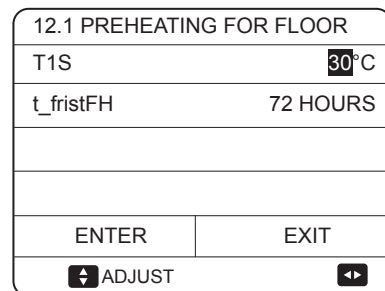

Fig. 121

When the cursor is on OPERATE PREHEATING FOR FLOOR, Use ◀ ▶ to scroll to YES and press OK. Fig. 122 will be displayed.

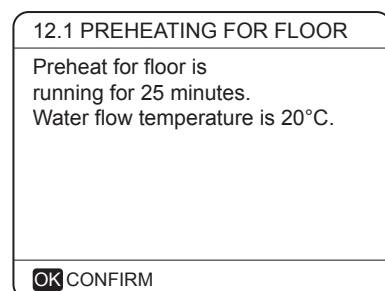

Fig. 122

During preheating for floor, all the buttons except OK are invalid. To turn off the preheating for floor, please press OK. Fig. 123 will be displayed.

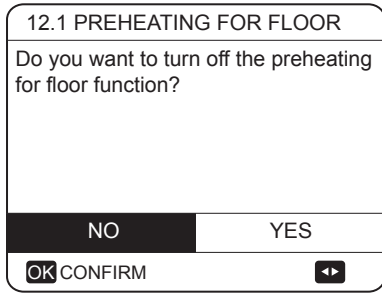

Fig. 123

Use ◀ ▶ to scroll the cursor to YES and press OK, the preheating for floor will turn off.

The operation of the unit during preheating for floor is described in Fig. 124 below.

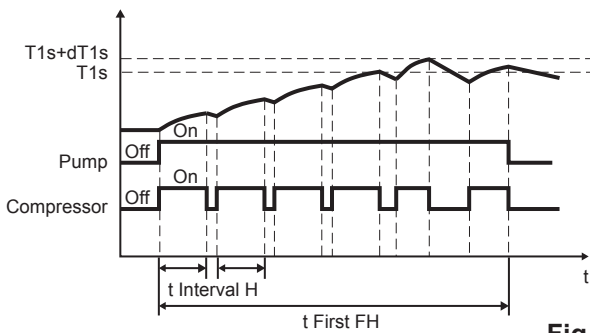

Fig. 124

If FLOOR DRYING UP is selected, after pressing OK, Figs. 124-125 will be displayed.

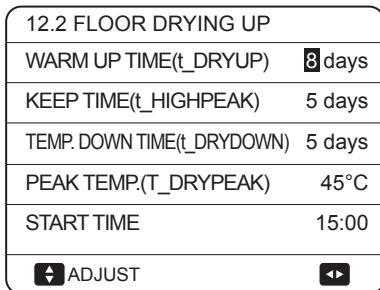

Fig. 125

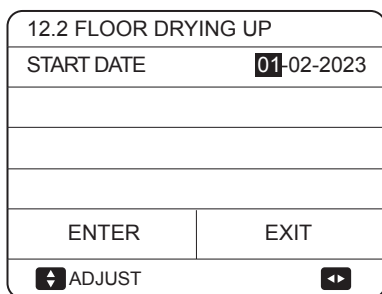

Fig. 126

During floor drying, all the buttons except OK are invalid. When the heat pump malfunctions, the floor drying mode will turn off when the backup heater and additional heating source is unavailable. To turn off floor drying up, please press OK. Fig. 127 will be displayed.

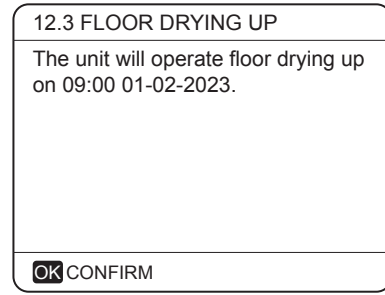

Fig. 127

Use ◀ ▶ to scroll the cursor to YES and press OK. Floor drying will turn off.

The target outlet water temperature during floor drying up is described in Fig. 128 below.

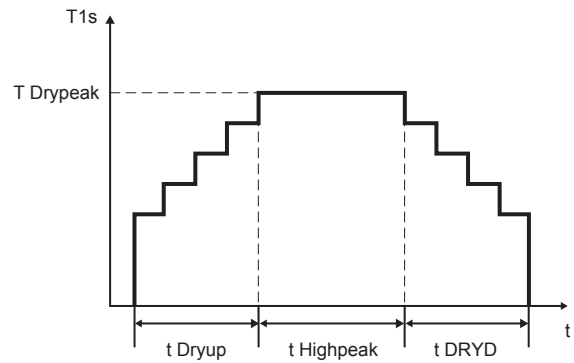

Fig. 128

10.5.13 Auto restart

The AUTO RESTART function is used to select whether the unit reapplies the user interface settings at the time when power returns after a power supply failure.

Go to MENU> FOR SERVICEMAN> 13. AUTO RESTART

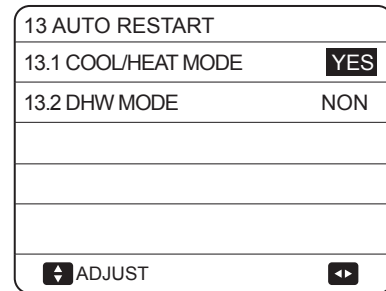

Fig. 129

The AUTO RESTART function reapplies the user interface settings at the time of the power supply failure. If this function is disabled, when power returns after a power supply failure, the unit will not auto restart.

10.5.14 Power input limitation

How to set the POWER INPUT LIMITATION

Go to MENU> FOR SERVICEMAN> 14. POWER INPUT LIMITATION

10.5.18 Setting parameters

The parameters related to this chapter are shown in the table below.

Order No.	Code	State	Default	Min.	Max.	Setting interval	Unit
1.1	DHW MODE	Enable or disable the DHW mode: 0=NON, 1=YES	1	0	1	1	/
1.2	DISINFECT	Enable or disable the disinfect mode: 0=NON, 1=YES	1	0	1	1	/
1.3	DHW PRIORITY	Enable or disable the DHW priority mode: 0=NON, 1=YES	1	0	1	1	/
1.4	DHW PUMP	Enable or disable the DHW pump mode: 0=NON, 1=YES	0	0	1	1	/
1.5	DHW PRIORITY TIME SET	Enable or disable the DHW priority time set: 0=NON, 1=YES	0	0	1	1	/
1.6	dT5_ON	The temperature difference for starting the heat pump	10	1	30	1	°C
1.7	dT1S5	The difference value between Twout and T5 in DHW mode	10	5	40	1	°C
1.8	T4DHWMAX	The maximum ambient temperature that the heat pump can operate at for domestic water heating	43	35	43	1	°C
1.9	T4DHWMIN	The minimum ambient temperature that the heat pump can operate for domestic water heating	-10	-25	30	1	°C
1.10	t_INTERVAL_DHW	The start time interval of the compressor in DHW mode.	5	5	5	1	MIN
1.11	dT5_TBH_OFF	the temperature difference between T5 and T5S that turns the booster heater off.	5	0	10	1	°C
1.12	T4_TBH_ON	the highest outdoor temperature the TBH can operate.	5	-5	50	1	°C
1.13	t_TBH_DELAY	the time that the compressor has run before starting the booster heater.	30	0	240	5	MIN
1.14	T5S_DI	the target temperature of water in the domestic hot water tank in the DISINFECT function.	65	60	70	1	°C
1.15	t_DI_HIGHTEMP.	the time that the highest temperature of water in the domestic hot water tank in the DISINFECT function will last.	15	5	60	5	MIN
1.16	t_DI_MAX	The maximum time that disinfection will last.	210	90	300	5	MIN
1.17	t_DHWHP_RESTRICT	The operation time for the space heating/cooling operation.	30	10	600	5	MIN
1.18	t_DHWHP_MAX	The maximum continuous working period of the heat pump in DHW PRIORITY mode.	90	10	600	5	MIN
1.19	DHW PUMP TIME RUN	Enable or disable the DHW pump run as timed and keeps running for PUMP RUNNING TIME: 0=NON, 1=YES	1	0	1	1	/
1.20	PUMP RUNNING TIME	the certain time that the DHW pump will keep running for.	5	5	120	1	MIN
1.21	DHW PUMP DISINFECT	Enable or disable the DHW pump operate when the unit is in disinfect mode and T5> T5S_DI-2: 0=NON, 1=YES	1	0	1	1	/
2.1	COOL MODE	Enable or disable the cooling mode:0=NON,1=YES S	1	0	1	1	Hours
2.2	t_T4_FRESH_C	The refresh time of climate related curves for cooling mode	0.5	0.5	6	0.5	°C
2.3	T4CMAX	The highest ambient operation temperature for cooling mode	52	35	52	1	°C
2.4	T4CMIN	the lowest ambient operating temperature for cooling mode	10	-5	25	1	°C
2.5	dT1SC	the temperature difference for starting the heat pump (T1)	5	2	10	1	°C
2.6	dTSC	the temperature difference for starting the heat pump (Ta)	2	1	10	1	°C
2.7	t_INTERVAL_COOL	the start time interval of the compressor in COOL mode	5	5	5	1	°C
2.8	T1SetC1	The setting temperature 1 of climate related curves for cooling mode	10	5	25	1	MIN
2.9	T1SetC2	The setting temperature 2 of climate related curves for cooling mode	16	5	25	1	°C
2.10	T4C1	The ambient temperature 1 of climate related curves for cooling mode	35	-5	46	1	°C
2.11	T4C2	The ambient temperature 2 of climate related curves for cooling mode	25	-5	46	1	°C
2.12	ZONE1 C-EMISSION	The type of zone1 end for cooling mode 0=FCU (fan coil unit), 1= RAD (radiator), 2= FLH (floor heating)	0	0	2	1	/
2.13	ZONE2 C-EMISSION	The type of zone2 end for cooling mode 0= FCU (fan coil unit), 1= RAD (radiator), 2= FLH (floor heating)	0	0	2	1	/

Order No.	Code	State	Default	Min.	Max.	Setting interval	Unit
3.1	HEAT MODE	Enable or disable the heating mode	1	0	1	1	/
3.2	t_T4_FRESH_H	The refresh time of climate related curves for heating mode	0.5	0.5	6	0.5	Hours
3.3	T4HMAX	The maximum ambient operating temperature for heating mode	25	20	35	1	°C
3.4	T4HMIN	The minimum ambient operating temperature for heating mode	-15	-25	30	1	°C
3.5	dT1SH	The temperature difference for starting the unit (T1)	5	2	20	1	°C
3.6	dTSH	The temperature difference for starting the unit (Ta)	2	1	10	1	°C
3.7	t_INTERVAL_HEAT	The start time interval of the compressor in HEAT mode	5	5	5	1	MIN
3.8	T1SetH1	The setting temperature 1 of climate related curves for heating mode	35	25	65	1	°C
3.9	T1SetH2	The setting temperature 2 of climate related curves for heating mode	28	25	65	1	°C
3.10	T4H1	The ambient temperature 1 of climate related curves for heating mode	-5	-25	35	1	°C
3.11	T4H2	The ambient temperature 2 of climate related curves for heating mode	7	-25	35	1	°C
3.12	ZONE1 H-EMISSION	The type of zone1 end for heating mode, 0=FCU (fan coil unit), 1= RAD (radiator), 2= FLH (floor heating)	1	0	2	1	/
3.13	ZONE2 H-EMISSION	The type of zone2 end for heating mode, 0= FCU (fan coil unit), 1=RAD (radiator), 2= FLH (floor heating)	2	0	2	1	/
3.14	t_DELAY_PUMP	the time that the compressor has run before starting the pump	2	0.5	20	0.5	MIN
4.1	T4AUTOCMIN	The minimum operating ambient temperature for cooling in auto mode	25	20	29	1	°C
4.2	T4AUTOHMAX	The maximum operating ambient temperature for heating in auto mode	17	10	17	1	°C
5.1	WATER FLOW TEMP.	Enable or disable the WATER FLOW TEMP. 0= NON, 1= YES	1	0	1	1	/
5.2	ROOM TEMP.	Enable or disable the ROOM TEMP. 0= NON, 1= YES	0	0	1	1	/
5.3	DOUBLE ZONE	Enable or disable the ROOM THERMOSTAT DOUBLE ZONE: 0= NON, 1= YES	0	0	1	1	/
6.1	ROOM THERMOSTAT	The style of room thermostat 0= NON, 1= MODE SET, 2= ONE ZONE, 3= DOUBLE ZONE	0	0	3	1	/
7.1	dT1_IBH_ON	The temperature difference between T1S and T1 for starting the backup heater.	5	2	10	1	°C
7.2	t_IBH_DELAY	The time that the compressor has run before the first backup heater turns on	30	15	120	5	MIN
7.3	T4_IBH_ON	The ambient temperature for starting the backup heater	-5	-15	30	1	°C
7.4	dT1_AHS_ON	The temperature difference between T1S and T1B for turning the additional heating source on	5	2	20	1	°C
7.5	t_AHS_DELAY	The time that the compressor has run before starting the additional heating source	30	5	120	5	MIN
7.6	T4_AHS_ON	The ambient temperature for starting the additional heating source	-5	-15	30	1	°C
7.7	IBH_LOCATE	IBH/AHS installation location PIPE LOOP=0; BUFFER TANK=1	0	0	0	0	°C
7.8	P_IBH1	Power input of IBH1	0	0	20	0.5	kW
7.9	P_IBH2	Power input of IBH2	0	0	20	0.5	kW
7.10	P_TBH	Power input of TBH	2	0	20	0.5	kW
8.1	T1S_H.A_H	The target outlet water temperature for space heating when in holiday away mode	25	20	25	1	°C
8.2	T5S_H.A_DHW	The target outlet water temperature for domestic hot water heating when in holiday away mode	25	20	25	1	°C
12.1	PREHEATING FOR FLOOR T1S	The setting temperature of outlet water during first preheating for floor	25	25	35	1	°C
12.3	t_FIRSTFH	The time last for preheating floor	72	48	96	12	Hour

Order No.	Code	State	Default	Min.	Max.	Setting interval	Unit
12.4	t_DRYUP	The day for warming up during floor drying up	8	4	15	1	DAY
12.5	t_HIGHPEAK	The continue days in high temperature during floor drying up	5	3	7	1	DAY
12.6	t_DRYD	The day of dropping temperature during floor drying up	5	4	15	1	DAY
12.7	T_DRYPEAK	The target peak temperature of water flow during floor drying up	45	30	55	1	°C
12.8	START TIME	The start time of floor drying up	Hour: the present time (not on the hour +1, on the hour +2) Minute:00	0:00	23:00	1/30	h/min
12.9	START DATE	The start date of floor drying up	The present date	1/1/2000	31/12/2099	1/1/2001	d/m/y
13.1	AUTO RESTART COOL/HEAT MODE	Enable or disable the auto restart cooling/heating mode. 0= NON, 1= YES	1	0	1	1	/
13.2	AUTO RESTART DHW MODE	Enable or disable the auto restart DHW mode. 0=NON, 1= YES	1	0	1	1	/
14.1	POWER INPUT LIMITATION	The type of power input limitation, 0= NON, 1~8= TYPE 1~8	0	0	8	1	/
15.1	ON/OFF (M1 M2)	Define the function of the M1M2 switch; 0= REMOTE ON/OFF, 1= TBH ON/OFF, 2= AHS ON/OFF	0	0	2	1	/
15.2	SMART GRID	Enable or disable the SMART GRID; 0=NON, 1=YES	0	0	1	1	/
15.3	T1b (Tw2)	Enable or disable the T1b(Tw 2); 0= NON, 1= YES	0	0	1	1	/
15.4	Tbt1	Enable or disable the Tbt1; 0= NON, 1= YES	0	0	1	1	/
15.5	Tbt2	Enable or disable the Tbt2; 0= NON, 1= YES	0	0	1	1	/
15.6	Ta	Enable or disable the Ta; 0= NON, 1= YES	0	0	1	1	/
15.7	Ta-adj	The corrected value of Ta on wired controller	-2	-10	10	1	°C
15.8	SOLAR INPUT	Choose the SOLAR INPUT; 0= NON ,1= CN18Tsolar, 2= CN11SL1SL2	0	0	2	1	/
15.9	F-PIPE LENGTH	Choose the total length of the liquid pipe (F-PIPE LENGTH); 0= F-PIPE LENGTH < 10m, 1= F-PIPE LENGTH >10m	0	0	1	1	/
15.10	RT/Ta_PCB	Enable or disable the RT/Ta_PCB; 0= NON, 1= YES	0	0	1	1	/
15.11	PUMPI SILENT MODE	Enable or disable PUMPI SILENT MODE 0= NON, 1= YES	0	0	1	1	/
16.1	PER_START	Start-up percentage of multiple units	10	10	100	10	%
16.2	TIME_ADJUST	Adjustment time of adding and subtracting units	5	1	60	1	MIN
16.3	ADDRESS RESET	Reset the address code of the unit	FF	0	15	1	/
17.1	HMI SET	Choose the HMI; 0= MASTER, 1= SLAVE	0	0	1	1	/
17.2	HMI ADDRESS FOR BMS	Set the HMI address code for BMS	1	1	16	1	/

11 Test run & Final checks

It is mandatory for the installer to verify the correct operation of unit after installation.

11.1 Final checks

Before switching on the unit, read the following recommendations:

- When the complete installation and all necessary settings have been carried out, close all front panels of the unit and refit the unit cover.
- The service panel of the switch box may only be opened by a licensed electrician for maintenance purposes.

NOTE

During the first running period of the unit, required power input may be higher than stated on the nameplate of the unit. This phenomenon originates from the compressor that needs a 50 hours run in period before reaching smooth operation and stable power consumption.

11.2 Test run operation (manually)

If required, the installer can perform a manual test run operation at any time to check correct operation of air purge, heating, cooling and domestic water heating, (see 10.5.11 Test run).

12 Maintenance & Service

In order to ensure optimal availability of the unit, a number of checks and inspections on the unit and the field wiring have to be carried out at regular intervals.

This maintenance needs to be carried out by your local technician.

DANGER

ELECTRIC SHOCK

- Before carrying out any maintenance or repairing activity, switch off the power supply on the supply panel.
- Do not touch any live part for 10 minutes after the power supply is turned off.
- The crank heater of compressor may operate even in standby.
- Some sections of the electric component box are hot.

- Do not touch any conductive parts.
- Do not rinse the unit. It may cause electric shock or fire.
- Do not leave the unit unattended when service panel is removed.

The following checks must be performed at least once a year by qualified personnel.

- Water pressure
Check the water pressure, if it is below 1 bar (0.1 MPa), fill water to the system.
- Water filter
Clean the water filter.
- Pressure relief valve hose
Check that the pressure relief valve hose is positioned appropriately to drain the water.
- Water pressure relief valve
Check for correct operation of the pressure relief valve by turning the black knob on the valve counter-clockwise:
 - If you do not hear a clacking sound, contact your local installer.
 - In case water keeps running out of the unit, close both the water inlet and outlet shut-off valves first and then contact your local installer.
- Backup heater vessel insulation cover
Check that the backup heater insulation cover is fastened tightly around the backup heater vessel.
- Domestic hot water tank pressure relief valve (field supply) Applies only to installations with a domestic hot water tank. Check for correct operation of the pressure relief valve on the domestic hot water tank.
- Domestic hot water tank booster heater
Applies only to installations with a domestic hot water tank. It is advisable to remove lime buildup on the booster heater to extend its life span, especially in regions with hard water. To do so, drain the domestic hot water tank, remove the booster heater from the domestic hot water tank and immerse in a bucket (or similar) with lime-removing product for 24 hours.
- Unit switch box
 - Carry out a thorough visual inspection of the switch box and look for obvious defects such as loose connections or defective wiring.
 - Check for correct operation of contactors with an ohm meter. They must be in open position.

- Use of glycol (see 9.4.4 “Water circuit anti-freeze protection”) Document the glycol concentration and the pH-value in the system at least once a year.
 - A PH-value below 8.0 indicates that a significant portion of the inhibitor has been depleted and that more inhibitor needs to be added.
 - When the PH-value is below 7.0 then oxidation of the glycol occurred. The system should be drained and flushed thoroughly before severe damage occurs.
- Make sure that the disposal of the glycol solution is done in accordance with relevant local laws and regulations.

13 Trouble Shooting

This section provides useful information for diagnosing and correcting certain troubles which may occur in the unit.

This troubleshooting and related corrective actions may only be carried out by your local technician.

13.1 General guidelines

Before starting the troubleshooting procedure, carry out a thorough visual inspection of the unit and look for obvious defects such as loose connections or defective wiring.

WARNING

When carrying out an inspection on the switch box of the unit, always make sure that the main switch of the unit is switched off.

When a safety device is activated, stop the unit and find out why it was activated before resetting it. Under no circumstances can safety devices be bridged or changed to a value other than the factory settings. If the cause of the problem cannot be found, call your local supplier.

If the pressure relief valve is not working correctly and is to be replaced, always reconnect the flexible hose attached to the pressure relief valve to avoid water dripping out of the unit!

NOTE

For problems related to the optional solar kit for domestic water heating, refer to the troubleshooting in the manual for that kit.

13.2 General symptoms

Symptom 1: The unit is turned on but the unit is not heating or cooling as expected

Possible causes	Corrective action
The temperature setting is not correct.	Check the parameters. T4HMAX, T4HMIN in heat mode. T4CMAX, T4CMIN in cool mode. T4DHWMAX, T4DHWMIN in DHW mode.
The water flow is too low.	<ul style="list-style-type: none"> • Check that all shut off valves of the water circuit are in the right position. • Check if the water filter is plugged. • Make sure there is no air in the water system. • Check the water pressure. • The water pressure must be > 1 bar (0.1 MPa) (at low temperature). • Make sure that the expansion vessel is not broken. • Check that the resistance in the water circuit is not too high for the pump.
The water volume in the installation is too low.	Make sure that the water volume in the installation is above the minimum required value (refer to 9.4.2 Water volume and sizing expansion vessels).

Symptom 2: The unit is turned on but the compressor is not starting (space heating or domestic water heating)

Possible causes	Corrective action
The unit maybe operate out of its operation range (the water temperature is too low).	<p>In case of low water temperature, the system utilizes the optional backup heater to reach the minimum water temperature first (12°C).</p> <ul style="list-style-type: none"> • Check that the backup heater power supply is correct. • Check that the backup heater thermal fuse is closed. • Check that the backup heater thermal protector is not activated. • Check that the backup heater contactors are not broken.

Symptom 3: Pump is making noise (cavitation)

Possible causes	Corrective action
There is air in the system.	Purge air.
Water pressure at pump inlet is too low.	<ul style="list-style-type: none"> • Check the water pressure The water pressure must be > 1 bar (0.1 MPa) (at low temperature). • Check that the expansion vessel is not broken. • Check that the setting of the pre-pressure of the expansion vessel is correct (refer to 9.4.2 Water volume and sizing expansion vessels).

Symptom 4: The water pressure relief valve opens

Possible causes	Corrective action
The expansion vessel is broken.	Replace the expansion vessel.
The filling water pressure in the installation is higher than 3 bar (0.3 MPa).	Make sure that the filling water pressure in the installation is about 1-2 bar (0.10-0.20 MPa) (refer to 9.4.2 Water volume and sizing expansion vessels).

Symptom 5: The water pressure relief valve leaks

Possible causes	Corrective action
Dirt is blocking the water pressure relief valve outlet.	<p>Check for correct operation of the pressure relief valve by turning the red knob on the valve counter clockwise:</p> <ul style="list-style-type: none"> • If you do not hear a clacking sound, contact your local supplier. • In case water keeps running out of the unit, close both the water inlet and outlet shut-off valves first and then contact your local supplier.

Symptom 6: Space heating capacity shortage at low outdoor temperatures

Possible causes	Corrective action
Backup heater operation is not activated.	<p>Check that the 'OTHER HEATING SOURCE/ BACKUP HEATER' is enabled, see '10.5 Field settings' Check whether or not the thermal protector of the backup heater has been activated (refer to 'Controls parts for backup heater (IBH)'). Check if booster heater is running, the backup heater and booster heater can't operate simultaneously.</p>
Too much heat pump capacity is used for heating domestic hot water (applies only to installations with a domestic hot water tank).	<p>Check that the 't_DHWHP_MAX' and 't_DHWHP_RESTRICT' are configured appropriately:</p> <ul style="list-style-type: none"> • Make sure that the 'DHW PRIORITY' in the user interface is disabled. • Enable the 'T4_TBH_ON' in the user interface / FOR SERVICEMAN to activate the booster heater for domestic water heating.

Symptom 7: Heat mode cannot change to DHW mode immediately

Possible causes	Corrective action
Volume of tank is too small and the location of water temperature probe not high enough.	<ul style="list-style-type: none"> • Set 'dT1S5' to maximum value, and set 't_DHWHP_RESTRICT' to minimum value. • Set 'dT1SH' to 2°C. • Enable TBH, and TBH should be controlled by the outdoor unit. • If AHS is available, turn on first, if requirement for turn heat pump on is fulfilled, the heat pump will turn on. • If both TBH and AHS are not available, try to change the position of T5 probe (refer to 2 General introduction).

Symptom 6: Space heating capacity shortage at low outdoor temperatures

Possible causes	Corrective action
Heat exchanger for space heating not big enough.	<ul style="list-style-type: none"> • Set 't_DHWHP_MAX' to minimum value, the suggested value is 60 min. • If circulating pump out of unit is not controlled by unit, try to connect it to the unit. • Add 3-way valve at the inlet of fan coil to ensure enough hot water flow.
Space heating load is small.	Normal, no need for heating.
Disinfect function is enabled but without TBH.	<ul style="list-style-type: none"> • Disable disinfect function. • add TBH or AHS for DHW mode.
When the ambient temperature is low, the hot water is not enough and the AHS is not operated or operated late.	<ul style="list-style-type: none"> • Set 'T4DHWMIN', the suggested value is > -5°C. • Set 'T4_TBH_ON', the suggested value is > -5°C.
DHW mode priority.	If there is AHS or IBH connect to the unit, when the outdoor unit failed, the hydraulic module board must run DHW mode till the water temperature reach the setting temperature before change to heating mode.

Symptom 9: DHW mode heat pump stop work but setpoint not reached, space heating require heat but unit stays in DHW mode

Possible causes	Corrective action
Surface of coil in the tank not large enough.	Refer to Symptom 7.
TBH or AHS not available.	Heat pump will stay in DHW mode until "t_DHWHP_MAX" reached or setpoint is reached. Add TBH or AHS for DHW mode, TBH and AHS should be controlled by the unit.

13.3 Operation parameter

This menu is for installer or service engineer reviewing the operation parameters.

At home page, go to "MENU">"OPERATION PARAMETER".

Press "OK". There are nine pages for the operating parameter as following. Press ▲ , ▼ to scroll.

Press ► and ◀ to check slave units' operation parameter in cascade system. The address code in the upper right corner will change from '#00' to '#01', '#02' etc. accordingly.

NOTE

The power consumption parameter is optional. If a parameter is not activated in the system, the parameter will show '--'.

The above heat pump criteria are for reference only. The accuracy of sensor is ±1°C. The flow rates parameters are calculated according to the pump running parameters, the deviation is different at different flow rates, the maximum of deviation is 15%. The flow parameters are calculated according to the electrical parameters of the pump operation. The operating voltage is different and the deviation is different. The display value is 0 when the voltage is less than 198V.

OPERATION PARAMETER	#00
ONLINE UNITS NUMBER	1
OPERATE MODE	COOL
SV1 STATE	ON
SV2 STATE	OFF
SV3 STATE	OFF
PUMP_I	ON
ADDRESS	1/9

OPERATION PARAMETER	#00
PUMP-O	OFF
PUMP-C	OFF
PUMP-S	OFF
PUMP-D	OFF
PIPE BACKUP HEATER	OFF
TANK BACKUP HEATER	ON
ADDRESS	2/9

OPERATION PARAMETER	#00
GAS BOILER	OFF
T1 LEAVING WATER TEMP.	35°C
WATER FLOW	1.72m3/h
HEAT PUMP CAPACTIY	11.52kW
POWER CONSUM.	1000kWh
Ta ROOM TEMP	25°C
ADDRESS	3/9

OPERATION PARAMETER	#00
T5 WATER TANK TEMP.	53°C
Tw2 CIRCUIT2 WATER TEMP.	35°C
TIS' C1 CLI. CURVE TEMP.	35°C
TIS2' C2 CLI. CURVE TEMP.	35°C
TW_O PLATE W-OUTLET TEMP.	35°C
TW_I PLATE W-OUTLET TEMP.	30°C
ADDRESS	4/9

OPERATION PARAMETER	#00
Tbt1 BUFFERTANK_UP TEMP.	35°C
Tbt2 BUFFERTANK_LOW TEMP.	35°C
Tsolar	25°C
IDU SOFTWARE	01-09-2019V01
ADDRESS	5/9

OPERATION PARAMETER	#00
ODU MODEL	6kW
COMP.CURRENT	12A
COMP.FREQUENCY	24Hz
COMP.RUN TIME	54 MIN
COMP.TOTAL RUN TIME	1000Hrs
EXPANSION VALVE	200P
ADDRESS	6/9

OPERATION PARAMETER	#00
FAN SPEED	600R/MIN
IDU TARGET FREQUENCY	46Hz
FREQUENCY LIMITED TYPE	5
SUPPLY VOLTAGE	230V
DC GENERATRIX VOLTAGE	420V
DC GENERATRIX CURRENT	18A
ADDRESS	7/9

OPERATION PARAMETER	#00
TW_O PLATE W-OUTLET TEMP.	35°C
TW_I PLATE W-INLET TEMP.	30°C
T2 PLATE F-OUT TEMP.	35°C
T2B PLATE F-IN TEMP.	35°C
Th COMP. SUCTION TEMP.	5°C
Tp COMP. DISCHARGE TEMP.	75°C
ADDRESS	8/9

OPERATION PARAMETER	#00
T3 OUTDOOR EXCHARGE TEMP.	5°C
T4 OUTDOOR AIR TEMP.	5°C
TF MODULE TEMP.	55°C
P1 COMP. PRESSURE	2300kPa
ODU SOFTWARE	01-09-2018V01
HMI SOFTWARE	01-09-2018V01
ADDRESS	9/9

13.4 Error codes

When a safety device is activated, an error code (which does not include external failure) will be displayed on the user interface.

A list of all errors and corrective actions can be found in the table below.

First, apply the relevant corrective action, then reset the safety device by turning the unit OFF and back ON.

In case this procedure for resetting the safety is not successful, contact your local supplier.

Error Code	Malfunction or Protection	Failure cause and corrective action
E0	Water flow fault (after 3 times E8)	<ol style="list-style-type: none"> 1) The wire circuit has short-circuited or is open. Reconnect the wire correctly. 2) Water flow rate is too low. 3) Water flow switch is failed, switch is open or closed continuously, change the water flow switch.
E2	Communication fault between controller and hydraulic module	<ol style="list-style-type: none"> 1) Wire does not connect between wired controller and unit. Connect the wire. 2) Communication wire sequence is not correct. Reconnect the wire in the correct sequence. 3) There is a high magnetic field or high power interfere, such as lifts, large power transformers, etc. Add a barrier to protect the unit or move the unit to a different location.
E3	Final outlet water temp.sensor (T1) fault	<ol style="list-style-type: none"> 1) Check the resistance of the sensor. 2) The T1 sensor connector is loose. Reconnect it. 3) The T1 sensor connector is wet or has water in. remove the water, dry the connector. Add waterproof adhesive. 4) The T1 sensor has failed, replace with a new sensor.
E4	water tank temp. sensor (T5) fault	<ol style="list-style-type: none"> 1) Check the resistance of the sensor. 2) The T5 sensor connector is loose. Reconnect it. 3) The T5 sensor connector is wet or has water in. remove the water, dry the connector. Add waterproof adhesive. 4) The T5 sensor has failed, replace with a new sensor. 5) To close the domestic water heating when T5 sensor is not connected to the system, then T5 sensor can not be detected, refer to 10.5.1 'DHW MODE SETTING'.
E7	Buffer tank up temp. sensor (Tbt1) fault	<ol style="list-style-type: none"> 1) Check the resistance of the sensor. 2) The Tbt1 sensor connector is loose, reconnect it. 3) The Tbt1 sensor connector is wet or has water in, remove the water, dry the connector. Add waterproof adhesive. 4) The Tbt1 sensor has failed, replace with a new sensor.
E8	Water flow failure	<p>Check that all shut off valves of the water circuit are completely open.</p> <ol style="list-style-type: none"> 1) Check if the water filter needs cleaning. 2) Refer to 9.5 Filling water. 3) Make sure there is no air in the system (purge air). 4) Check the water pressure. The water pressure must be >1 bar (0.1 MPa). 5) Check that the pump speed setting is on the highest speed. 6) Make sure that the expansion vessel is not broken. 7) Check that the resistance in the water circuit is not too high for the pump (refer to 10.4 The circulation pump). 8) If this error occurs at defrost operation (during space heating or domestic water heating), make sure that the backup heater power supply is wired correctly and that fuses are not blown. 9) Check that the pump fuse and PCB fuse are not blown.

Error Code	Malfunction or Protection	Failure cause and corrective action
Eb	Solar temp.sensor (Tsolar) fault	<ol style="list-style-type: none"> 1) Check the resistance of the sensor. 2) The Tsolar sensor connector is loose, reconnect it. 3) The Tsolar sensor connector is wet or has water in, remove the water, dry the connector. Add waterproof adhesive. The Tsolar sensor has failed, replace with a new sensor.
Ec	Buffer tank low temp. sensor(Tbt2) fault	<ol style="list-style-type: none"> 1) Check the resistance of the sensor. 2) The Tbt12 sensor connector is loose, reconnect it. 3) The Tbt2 sensor connector is wet or has water in, remove the water, dry the connector. Add waterproof adhesive. 4) The Tbt2 sensor has failed, replace with a new sensor.
Ed	Inlet water temp. sensor (Tw_in) malfunction	<ol style="list-style-type: none"> 1) Check the resistance of the sensor 2) The Tw_in sensor connector is loose. Reconnect it. 3) The Tw_in sensor connector is wet or has water in. Remove the water, dry the connector. Add waterproof adhesive. 4) The Tw_in sensor has failed, replace with a new sensor.
Ee	Hydraulic module EEPROM failure	<ol style="list-style-type: none"> 1) The EEPROM parameter is error, rewrite the EEPROM data. 2) EEPROM chip part is broken, replace with a new EEPROM chip part. 3) Main control board of hydraulic module is broken, replace with a new PCB.
H0	Communication fault between main board PCB B and main control board of hydraulic module	<ol style="list-style-type: none"> 1) Wire doesn't connect between main control board PCB B and main control board of hydraulic module. Connect the wire. 2) Communication wire sequence is not correct. Reconnect the wire in the correct sequence. 3) There is a high magnetic field or high power interfere, such as lifts, large power transformers, etc. Add a barrier to protect the unit or move the unit to a different location.
H2	Refrigerant liquid temp. sensor (T2) fault	<ol style="list-style-type: none"> 1) Check the resistance of the sensor. 2) The T2 sensor connector is loose. Reconnect it. 3) The T2 sensor connector is wet or has water in. Remove the water, dry the connector. Add waterproof adhesive. 4) The T2 sensor has failed, replace with a new sensor.
H3	Refrigerant gas temp. sensor (T2B) fault	<ol style="list-style-type: none"> 1) Check the resistance of the sensor. 2) The T2B sensor connector is loose. Reconnect it. 3) The T2B sensor connector is wet or has water in. Remove the water, dry the connector. Add waterproof adhesive 4) The T2B sensor has failed, replace with a new sensor.
H5	Room temp. sensor (Ta) fault	<ol style="list-style-type: none"> 1) Check the resistance of the sensor. 2) The Ta sensor is in the interface. 3) The Ta sensor has failed, replace with a new sensor or change a new interface, or reset the Ta, connect a new Ta from the hydraulic module PCB.
H9	Outlet water for zone 2 temp. sensor (Tw2) fault	<ol style="list-style-type: none"> 1) Check the resistance of the sensor. 2) The Tw2 sensor connector is loose. Reconnect it. 3) The Tw2 sensor connector is wet or has water in. Remove the water, dry the connector. Add waterproof adhesive. 4) The Tw2 sensor has failed, replace with a new sensor.
HA	Outlet water temp. sensor (Tw_out) fault	<ol style="list-style-type: none"> 1) The TW_out sensor connector is loose. Reconnect it. 2) The TW_out sensor connector is wet or has water in. Remove the water, dry the connector. Add waterproof adhesive. 3) The TW_out sensor has failed, replace with a new sensor.
Hb	Three times "PP" protection and Tw_out < 7°C	Refer to 'PP'.

Error Code	Malfunction or Protection	Failure cause and corrective action
Hd	Communication fault between hydraulic module parallel	<ol style="list-style-type: none"> 1) The signal wires of slave units and master unit are not effectively connected. After checking all signal wires are well connected and making sure there is no strong electricity or strong magnetic interference, power on again. 2) There are two or more outdoor units connected to the wired controller. After removing the excess wired controller and keeping only the wired controller of the master unit, power on again. 3) The power-on interval between the master unit and the slave unit is longer than 2 minutes. After ensuring that the interval between the power-on of all the master units and slave units is less than 2 minutes, power on again. 4) The addresses of master unit and slave units are repeated: by pressing the SW2 button on main board once on slave units, the address code of the slave unit will be displayed on the digital tube (Normally address code, one of 1, 2, 3 ... 15 will be shown on main board), check whether there is a duplicate address. If there is a duplicate address, after powering off the system, set the S4-1 to 'ON' on master outdoor unit main board or the slave outdoor unit main board which display 'Hd' error (refer to 10.2.1 Function setting). Power on again, wait for 5 minutes to make sure the 'Hd' error does not display again, power off again and set the S4-1 to 'OFF'. The system will recover.
HE	Communication error between main board and thermostat transfer board	<p>RT/Ta PCB is set to be valid on user interface but thermostat transfer board is not connected or the communication between thermostat transfer board and main board is not functional. If thermostat transfer board is not needed, set the RT/Ta PCB to invalid. If thermostat transfer board is needed, please connect it to main board and make sure the communication wire is connected correctly and there is no strong electricity or strong magnetic interference.</p>
PS	(Tw_out - Tw_in) value too big protection	<ol style="list-style-type: none"> 1) Check that all shut off valves of the water circuit are completely open. 2) Check if the water filter needs cleaning. 3) Refer to '9.5 Filling water'. 4) Make sure there is no air in the system (purge air). 5) Check the water pressure. The water pressure must be > 1 bar (0.1 MPa) (at low temperature). 6) Check that the pump speed setting is on the highest setting. 7) Make sure that the expansion vessel is not broken. 8) Check that resistance in the water circuit is not too high for the pump (refer to '10.4 The circulation pump').
Pb	Anti freeze mode	Unit will return to the normal operation automatically.
PP	Tw_out - Tw_in unusual protection	<ol style="list-style-type: none"> 1) Check the resistance of the two sensors. 2) Check the two sensors location. 3) The water inlet/outlet sensor wire connector is loose, reconnect it. 4) The water inlet/outlet (TW_in/TW_out) sensor is broken, replace with a new sensor. 5) Four-way valve is blocked. Restart the unit again to let the valve change the direction. 6) Four-way valve is broken, replace with a new sensor.

⚠ CAUTION

In winter, if the unit has E0 and/or Hb failure and the unit is not repaired in time, the water pump and pipeline system may be damaged by freezing. Make sure to correct these failures rapidly.

Error Code	Malfunction or Protection	Failure cause and corrective action
E1	Phase loss or neutral wire and live wire are connected reversely (only for three phase unit)	<ol style="list-style-type: none"> 1) Check the power supply cables are firmly connected, avoid phase loss. 2) Check whether the sequence of neutral wire and live wire are connected reversely.
E5	The condenser outlet refrigerant temperature sensor (T3) error.	<ol style="list-style-type: none"> 1) The T3 sensor connector is loose. Reconnect it. 2) The T3 sensor connector is wet or has water in. Remove the water, dry the connector. Add waterproof adhesive. 3) The T3 sensor has failed, replace with a new sensor.
E6	The ambient temperature sensor (T4) error.	<ol style="list-style-type: none"> 1) The T4 sensor connector is loose. Reconnect it. 2) The T4 sensor connector is wet or has water in. Remove the water, dry the connector. Add waterproof adhesive. 3) The T4 sensor has failed, replace with a new sensor.
E9	Suction temperature sensor (Th) error	<ol style="list-style-type: none"> 1) The Th sensor connector is loose. Reconnect it. 2) The Th sensor connector is wet or has water in. Remove the water, dry the connector. Add waterproof adhesive. 3) The Th sensor has failed, replace with a new sensor.
EA	Discharge temperature sensor (Tp) error	<ol style="list-style-type: none"> 1) The Tp sensor connector is loose. Reconnect it. 2) The Tp sensor connector is wet or has water in. Remove the water, dry the connector. Add waterproof adhesive 3) The Tp sensor has failed, replace with a new sensor.
H0	Communication fault between main board PCB B and main control board of hydraulic module	<ol style="list-style-type: none"> 1) Wire does not connect between main control board PCB B and main control board of hydraulic module. Connect the wire. 2) Communication wire sequence is not correct. Reconnect the wire in the correct sequence. 3) There is a high magnetic field or high power interfere, such as lifts, large power transformers, etc. Add a barrier to protect the unit or move the unit to a different location.
H1	Communication error between inverter module PCB A and main control board PCB B	<ol style="list-style-type: none"> 1) Check if there is power connected to the PCB and driven board. Check the inverter module PCB indicator light is on or off. If light is off, reconnect the power supply wire. 2) If light is on, check the wire connection between inverter module PCB and main control board PCB, if the wire loose or broken, reconnect the wire or replace it. 3) Replace a new main PCB and driven board one by one.
H4	Three times P6 (L0/L1) protect	The sum of the number of times L0 and L1 appear in an hour equals three. See L0 and L1 for fault handling methods.
H6	The DC fan failure	<ol style="list-style-type: none"> 1) Strong wind or typhoon towards the fan, making the fan run in the opposite direction. Change the unit direction or make shelter to avoid typhoon. 2) fan motor is broken, replace with a new fan motor.
H7	Voltage protection	<ol style="list-style-type: none"> 1) Check whether the power supply input is in the available range. 2) Power off and power on several times rapidly. Keep the unit power off for more than 3 minutes then power on. 3) The circuit defect part of Main control board is defective. Replace with a new Main PCB.
H8	Pressure sensor failure	<ol style="list-style-type: none"> 1) Pressure sensor connector is loose, reconnect it. 2) Pressure sensor failure. Replace with a new sensor.
HF	Inverter module board EE prom failure	<ol style="list-style-type: none"> 1) The EE prom parameter is erroneous, rewrite the EE prom data. 2) EE prom chip part is broken, replace with a new EE prom chip part. 3) Inverter module board is broken, replace with a new PCB.
HH	H6 displayed 10 times in 2 hours	Refer to H6.

Error Code	Malfunction or Protection	Failure cause and corrective action
HP	Low pressure protection in cooling Pe < 0.6 occurred 3 times in an hour.	Refer to P0.
P0	Low pressure switch protection	<ol style="list-style-type: none"> 1) System is lacking of refrigerant. Charge the refrigerant in right volume. 2) When in heating mode or DHW mode, the outdoor heat exchanger is dirty or blocked on the surface. Clean the outdoor heat exchanger or remove the obstruction. 3) The water flow is too low in cooling mode. Increase the water flow. 4) Electrical expansion valve locked or winding connector is loose. Tap the valve body and plug in/plug off the connector for several times to make sure the valve is working correctly.
P1	High pressure switch protection	<p>Heating mode, DHW mode:</p> <ol style="list-style-type: none"> 1) The water flow is low; water temp is high, whether there is air in the water system. Release the air. 2) Water pressure is lower than 1 bar (0.1 MPa) charge the water to let the pressure in the range of 1.5-2 bar (0.15-0.2 MPa). 3) Over charge the refrigerant volume. Recharge the refrigerant in right volume. 4) Electrical expansion valve locked or winding connector is loose. Tap-tap the valve body and plug in/plug off the connector for several times to make sure the valve is working correctly and install the winding in the right location. <p>DHW mode: Water tank heat exchanger is smaller.</p> <p>Cooling mode:</p> <ol style="list-style-type: none"> 1) Heat exchanger cover is not removed. Remove it. 2) Heat exchanger is dirty or something is blocked on the surface. Clean the heat exchanger or remove the obstruction.
P3	Compressor overcurrent protection.	<ol style="list-style-type: none"> 1) Refer to P1. 2) Power supply voltage of the unit is low, increase the power voltage to the required range.
P4	High discharge temperature protection.	<ol style="list-style-type: none"> 1) Refer to P1. 2) TW_out temp. sensor is loose. Reconnect it. 3) T1 temp. sensor is loose. Reconnect it. 4) T5 temp. sensor is loose. Reconnect it.
Pd	High temperature protection of refrigerant outlet temp of condenser.	<ol style="list-style-type: none"> 1) Heat exchanger cover is not removed. Remove it. 2) Heat exchanger is dirty or blocked on the surface. Clean the heat exchanger or remove the obstruction. 3) There is not enough space around the unit for heat exchanging. 4) Fan motor is broken, replace with a new one.
E7	Transducer module temperature too high protection.	<ol style="list-style-type: none"> 1) Power supply voltage of the unit is low, increase the power voltage to the required range. 2) The space between the units is too narrow for heat exchange. Increase the space between the units. 3) Heat exchanger is dirty or something is blocked on the surface. Clean the heat exchanger or remove the obstruction. 4) Fan is not running. Fan motor or fan is broken, replace with a new fan or fan motor. 5) Water flow rate is low, there is air in system, or pump head is not enough. Release the air and reselect the pump. 6) Water outlet temp. sensor is loose or broken, reconnect it or replace with a new one.
F1	Low DC generatrix voltage protection	<ol style="list-style-type: none"> 1. Check the power supply. 2. If the power supply is OK and LED light is OK, check the voltage PN, if it is 380V, the problem usually comes from the main board. If the light is OFF, disconnect the power, check the IGBT, check the dioxides. If the voltage is not correct the inverter board is damaged, change it. 3. If the IGBT are OK which means the inverter board is OK, power from rectifier bridge is not correct. Check the bridge (Same method as IGBT, disconnect the power, check if dioxides are damaged). 4. Usually if F1 occurs at compressor startup the possible reason is main board. If F1 occurs at fan startup it may be because of inverter board.

Error Code		Malfunction or Protection	Failure cause and corrective action
	bH	PED PCB failure	<ol style="list-style-type: none"> 1) After 5 minutes of power-off interval, power on again and observe whether it can be recovered; 2) If it cannot be restored, replace PED safety plate, power on again and observe whether it can be restored; 3) If it can not be recovered, the IPM module board should be replaced.
P6	L0	Module protection	<ol style="list-style-type: none"> 1) Check the Heat pump system pressure. 2) Check the phase resistance of compressor. 3) Check the U, V, W power line connection sequence between the inverter board and the compressor. 4) Check the L1, L2, L3 power line connection between the inverter board and the Filter board. 5) Check the inverter board.
	L1	DC generatrix low voltage protection	
	L2	DC generatrix high voltage protection	
	L4	MCE malfunction	
	L5	Zero speed protection	
	L8	Speed difference > 15Hz protection between the front and the back clock	
	L9	Speed difference > 15Hz protection between the real and the setting speed	

14 Technical Specifications

14.1 General

Model	1-phase 4/5kW	1-phase 7/8kW	1-phase 11/13kW	3-phase 11/13kW
Nominal capacity	Refer to the Technical Data			
Dimensions H x W x D	792 × 1295 × 429mm	845 × 1385 × 526mm	845 × 1385 × 526mm	845 × 1385 × 526mm
Weight (without backup heater)				
Net weight	98kg	121kg	144kg	160kg
Gross weight	121kg	148kg	170kg	188kg
Connections				
water inlet/outlet	G1" BSP	G1 1/4" BSP	G1 1/4" BSP	G1 1/4" BSP
Water drain	hose nipple			
Expansion vessel				
Volume	8L			
Maximum working pressure (MWP)	8 bar (0.8 MPa)			
Pump				
Type	Water cooled	Water cooled	Water cooled	Water cooled
No. of speed	Variable speed	Variable speed	Variable speed	Variable speed
Pressure relief valve water circuit	3 bar (0.3 MPa)			
Operation range - water side				
Heating	+12~+65°C			
Cooling	+5~+25°C			
Operation range - air side				
Heating	-25~35°C			
Cooling	-5~43°C			
Domestic hot water by heat pump	-25~43°C			

14.2 Electrical specifications

Model		1-phase 4/5/7/8/11/13kW	3-phase 11/13kW
Standard unit	Power Supply	220-240V~ 50Hz	380-415V 3N~ 50Hz
	Nominal Running Current	See 9.7.4 Safety device requirement	
Backup heater	Power Supply	See 9.7.4 Safety device requirement	
	Nominal Running Current	See 9.7.4 Safety device requirement	

15 Information servicing

1) Checks to the area

Prior to beginning work on systems containing flammable refrigerants, safety checks are necessary to ensure that the risk of ignition is minimised. For repair to the refrigerating system, the following precautions shall be complied with prior to conducting work on the system.

2) Work procedure

Works shall be undertaken under a controlled procedure to minimise the risk of a flammable gas or vapour being present while the work is performed.

3) General work area

All maintenance staff and others working in the local area shall be instructed on the nature of work being carried out. Work in confined spaces shall be avoided. The area around the work space shall be sectioned off. Ensure that the conditions within the area have been made safe by control of flammable material.

4) Checks for presence of refrigerant

The area shall be checked with an appropriate refrigerant detector prior to and during work, to ensure the technician is aware of potentially flammable atmospheres. Ensure that the leak detection equipment being used is suitable for use with flammable refrigerants, i.e. no sparking, adequately sealed or intrinsically safe.

5) Presence of fire extinguisher

If any hot work is to be conducted on the refrigeration equipment or any associated parts, appropriate fire extinguishing equipment shall be available to hand. Have a dry powder or CO₂ fire extinguisher adjacent to the charging area.

6) No ignition sources

No person carrying out work in relation to a refrigeration system which involves exposing any pipe work that contains or has contained flammable refrigerant shall use any sources of ignition as it may lead to the risk of fire or explosion. All possible ignition sources, including cigarette smoking, should be kept sufficiently far away from the site of installation, repairing, removing and disposal, during which flammable refrigerant can possibly be released to the surrounding space. Prior to work taking place, the area around the equipment is to be surveyed to make sure that there are no flammable hazards or ignition risks. NO SMOKING signs shall be displayed.

7) Ventilated area

Ensure that the area is in the open or that it is adequately ventilated before breaking into the system or conducting any work. A degree of ventilation shall continue during the period that the work is carried out. The ventilation should safely disperse any released refrigerant and preferably expel it externally into the atmosphere.

8) Checks to the refrigeration equipment

Refrigerant components should be changed by an F-Gas qualified engineer using only genuine Baxi parts. At all times the manufacturers maintenance and service guidelines shall be followed. If in doubt consult the manufacturers technical department for assistance. The following checks shall be applied to installations using flammable refrigerants.

- The ventilation machinery and outlets are operating adequately and are not obstructed.
- If an indirect refrigerating circuit is being used, the secondary circuits shall be checked for the presence of refrigerant; marking to the equipment continues to be visible and legible.
- Marking and signs that are illegible shall be corrected.
- Refrigeration pipe or components are installed in a position where they are unlikely to be exposed to any substance which may corrode refrigerant containing components, unless the components are constructed of materials which are inherently resistant to being corroded or are suitably protected against being corroded.

9) Checks to electrical devices

Repair and maintenance to electrical components shall include initial safety checks and component inspection procedures. If a fault exists that could compromise safety, then no electrical supply shall be connected to the circuit until it is satisfactorily dealt with. If the fault cannot be corrected immediately but it is necessary to continue operation, an adequate temporary solution shall be used. This shall be reported to the owner of the equipment so all parties are advised.

Initial safety checks shall include:

- That capacitors are discharged: this shall be done in a safe manner to avoid possibility of sparking.
- That there no live electrical components and wiring are exposed while charging, recovering or purging the system.
- That there is continuity of earth bonding.

10) Repairs to sealed components

- a) During repairs to sealed components, all electrical supplies shall be disconnected from the equipment being worked upon prior to any removal of sealed covers, etc. If it is absolutely necessary to have an electrical supply to equipment during servicing, then a permanently operating form of leak detection shall be located at the most critical point to warn of a potentially hazardous situation.
- b) Particular attention shall be paid to the following to ensure that by working on electrical components, the casing is not altered in such a way that the level of protection is affected. This shall include damage to cables, excessive number of connections, terminals

not made to original specification, damage to seals, incorrect fitting of glands, etc.

- Ensure that apparatus is mounted securely.
- Ensure that seals or sealing materials have not degraded such that they no longer serve the purpose of preventing the ingress of flammable atmospheres. Replacement parts shall be in accordance with the manufacturers specifications.

NOTE

The use of silicon sealant may inhibit the effectiveness of some types of leak detection equipment. Intrinsically safe components do not have to be isolated prior to working on them.

removed or extinguished. If a leakage of refrigerant is found which requires brazing, all of the refrigerant shall be recovered from the system or isolated (by means of shut off valves) in a part of the system remote from the leak. Oxygen free nitrogen (OFN) shall then be purged through the system both before and during the brazing process.

15) Removal and evacuation

When breaking into the refrigerant circuit to make repairs for any other purpose, conventional procedures shall be used. However, it is important that best practice is followed since flammability is a consideration. The following procedure shall be adhered to:

- Remove refrigerant;
- Purge the circuit with inert gas;
- Evacuate;
- Purge again with inert gas;
- Open the circuit by cutting or brazing.

The refrigerant charge shall be recovered into the correct recovery cylinders. The system shall be flushed with OFN to render the unit safe. This process may need to be repeated several times.

Compressed air or oxygen shall not be used for this task.

Flushing shall be achieved by breaking the vacuum in the system with OFN and continuing to fill until the working pressure is achieved, then venting to atmosphere and finally pulling down to a vacuum. This process shall be repeated until no refrigerant is within the system.

When the final OFN charge is used, the system shall be vented down to atmospheric pressure to enable work to take place. This operation is absolutely vital if brazing operations on the pipe-work are to take place. Ensure that the outlet for the vacuum pump is not closed to any ignition sources and there is ventilation available.

16) Charging procedures

In addition to conventional charging procedures, the following requirements shall be followed:

- Ensure that contamination of different refrigerants does not occur when using charging equipment. Hoses or lines shall be as short as possible to minimize the amount of refrigerant contained in them.
- Cylinders shall be kept upright.
- Ensure that the refrigeration system is earthed prior to charging the system with refrigerant.
- Label the system when charging is complete (if not already).

11) Repair to intrinsically safe components

Do not apply any permanent inductive or capacitance loads to the circuit without ensuring that this will not exceed the permissible voltage and current permitted for the equipment in use. Intrinsically safe components are the only types that can be worked on while live in the presence of a flammable atmosphere. The test apparatus shall be at the correct rating. Replace components only with parts specified by the manufacturer. Other parts may result in the ignition of refrigerant in the atmosphere from a leak.

12) Cabling

Check that cabling will not be subjected to wear, corrosion, excessive pressure, vibration, sharp edges or any other adverse environmental effects. The check shall also take into account the effects of aging or continual vibration from sources such as compressors or fans.

13) Detection of flammable refrigerants

Under no circumstances shall potential sources of ignition be used in the searching for or detection of refrigerant leaks. A halide torch (or any other detector using a naked flame) shall not be used.

14) Leak detection methods

The following leak detection methods are deemed acceptable for systems containing flammable refrigerants. Electronic leak detectors shall be used to detect flammable refrigerants, but the sensitivity may not be adequate, or may need re-calibration. (detection equipment shall be calibrated in a refrigerant-free area.) Ensure that the detector is not a potential source of ignition and is suitable for the refrigerant. Leak detection equipment shall be set at a percentage of the LFL of the refrigerant and shall be calibrated to the refrigerant employed and the appropriate percentage of gas (25% maximum) is confirmed. Leak detection fluids are suitable for use with most refrigerants but the use of detergents containing chlorine shall be avoided as the chlorine may react with the refrigerant and corrode the copper pipe-work. If a leak is suspected, all naked flames shall be

- Extreme care shall be taken not to overfill the refrigeration system.
- Prior to recharging the system it shall be pressure tested with OFN. The system shall be leak tested on completion of charging but prior to commissioning. A follow up leak test shall be carried out prior to leaving the site.

17) Decommissioning

Before carrying out this procedure it is essential that the technician is completely familiar with the equipment and all its details. It is recommended good practice that all refrigerants are recovered safely. Prior to the task being carried out, an oil and refrigerant sample shall be taken.

In case analysis is required prior to re-use of reclaimed refrigerant. It is essential that electrical power is available before the task is commenced.

- Become familiar with the equipment and its operation.
- Isolate system electrically.
- Before attempting the procedure ensure that:
 - Mechanical handling equipment is available if required for handling refrigerant cylinders.
 - All personal protective equipment is available and being used correctly.
 - The recovery process is supervised at all times by a competent personnel.
 - Recovery equipment and cylinders conform to the appropriate standards.
- Pump down refrigerant system, if possible.
- If a vacuum is not possible, make a manifold so that refrigerant can be removed from various parts of the system.
- Make sure that cylinder is situated on the scales before recovery takes place.
- Start the recovery machine and operate in accordance with manufacturers instructions.
- Do not overfill cylinders. (No more than 80% volume liquid charge).
- Do not exceed the maximum working pressure of the cylinder, even temporarily.
- When the cylinders have been filled correctly and the process completed, make sure that the cylinders and the equipment are removed from site promptly and all isolation valves on the equipment are closed off.
- Recovered refrigerant shall not be charged into another refrigeration system unless it has been cleaned and checked.

18) Labelling

Equipment shall be labelled stating that it has been de-commissioned and emptied of refrigerant. The label shall be dated and signed. Ensure that there are labels on the equipment stating the equipment contains flammable refrigerant.

19) Recovery

When removing refrigerant from a system either for service or decommissioning, it is recommended good practice that all refrigerants are removed safely.

When transferring refrigerant into cylinders, ensure that only appropriate refrigerant recovery cylinders are employed. Ensure that the correct numbers of cylinders for holding the total system charge are available. All cylinders to be used are designated for the recovered refrigerant and labelled for that refrigerant (i.e special cylinders for the recovery of refrigerant). Cylinders shall be complete with pressure relief valve and associated shut-off valves in good working order. Empty recovery cylinders are evacuated and if possible cooled before recovery occurs. The recovery equipment shall be in good working order with a set of instructions concerning the equipment that is at hand and shall be suitable for the recovery of flammable refrigerants. In addition, a set of calibrated weighing scales shall be available and in good working order.

Hoses shall be complete with leak-free disconnect couplings and in good condition. Before using the recovery machine check that it is in satisfactory working order, has been properly maintained and that any associated electrical components are sealed to prevent ignition in the event of a refrigerant release. Consult manufacturer if in doubt. The recovered refrigerant shall be returned to the refrigerant supplier in the correct recovery cylinder and the relevant Waste Transfer Note arranged. Do not mix refrigerants in recovery units and especially not in cylinders. If compressors or compressor oils are to be removed, ensure that they have been evacuated to an acceptable level to make certain that flammable refrigerant does not remain within the lubricant. The evacuation process shall be carried out prior to returning the compressor to the suppliers. Only electric heating to the compressor body shall be employed to accelerate this process. When oil is drained from a system it shall be carried out safely.

20) Transportation, marking and storage for units

Transport of equipment containing flammable refrigerants Compliance with the transport regulations.

Marking of equipment using signs Compliance with local regulations.

Disposal of equipment using flammable refrigerants Compliance with national regulations.

Storage of equipment/appliances. In accordance with the manufacturer's instructions.

Storage of packed (unsold) equipment. Protection should be provided such that mechanical damage to the equipment inside.

The package will not cause any leak.

The maximum number of pieces of equipment permitted to be stored together will be determined by local regulations.

Annex A: Refrigerant cycle

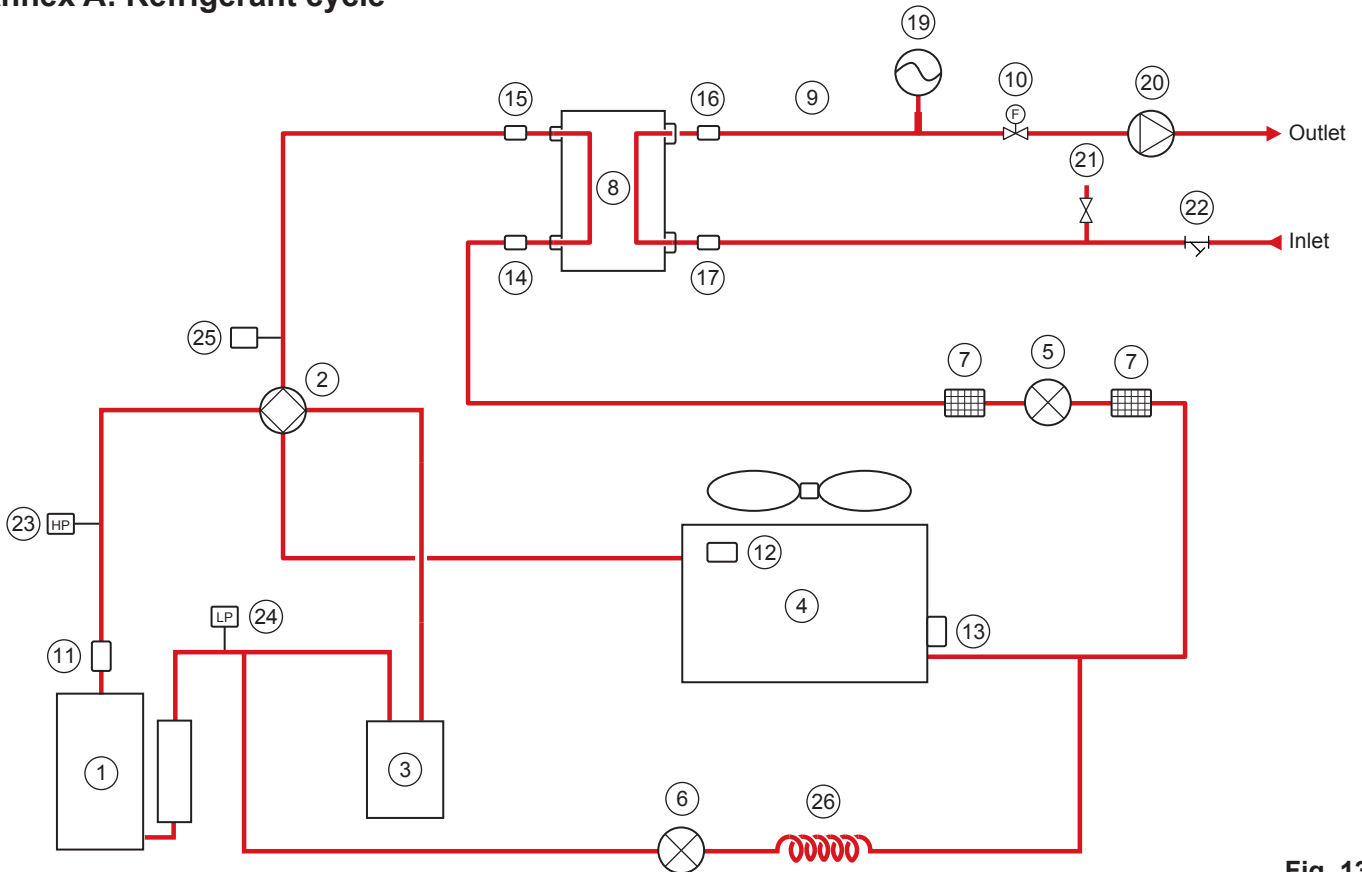

Fig. 137

	Description		Description
1	Compressor	14	Refrigerant inlet (liquid pipe) temperature sensor
2	4-Way Valve	15	Refrigerant outlet (gas pipe) temperature sensor
3	Gas-liquid separator	16	Water outlet temperature sensor
4	Air side heat exchanger	17	Water inlet temperature sensor
5	Electronic expansion valve	18	Automatic air purge valve
6	Single-way electromagnetic valve	19	Expansion vessel
7	Strainer	20	Circulating pump
8	Water side heat exchanger (Plate heat exchanger)	21	Pressure relief valve
9	Flow Pipe	22	Y-shape filter
10	Flow switch	23	High pressure switch
11	Discharge gas sensor	24	Low pressure switch
12	Outdoor temperature sensor	25	Pressure sensor
13	Evaporation sensor in heating (Condenser sensor in cooling)	26	Capillary

Annex B:
To install the E-heating tape at the drainage outlet (by client)

Connect the wires of E-heater tape which works for the drainage outlet pipe to the wire joint XT3.

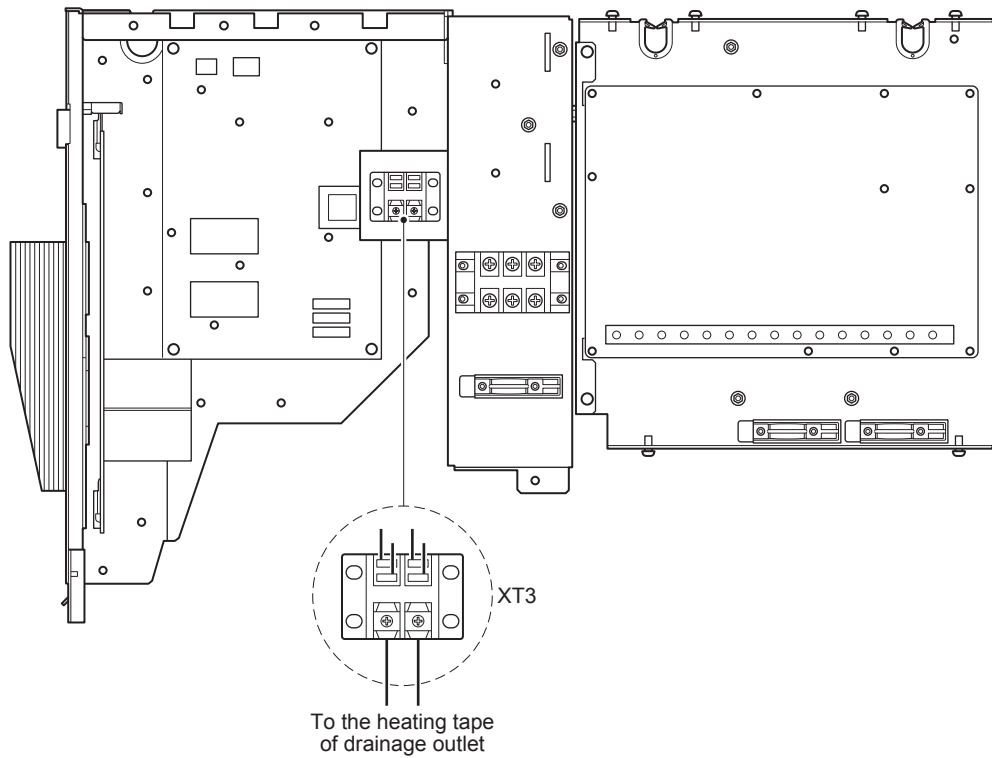

Fig. 138

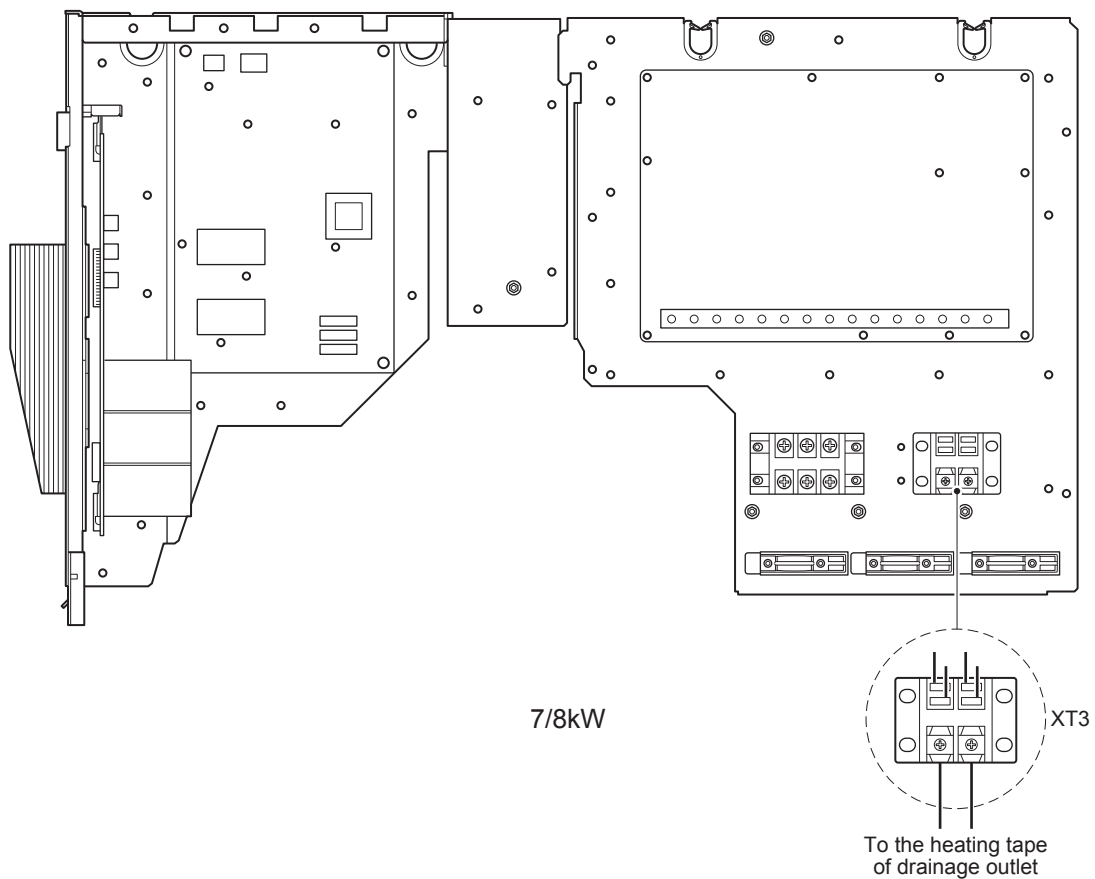

Fig. 139

Annex B:

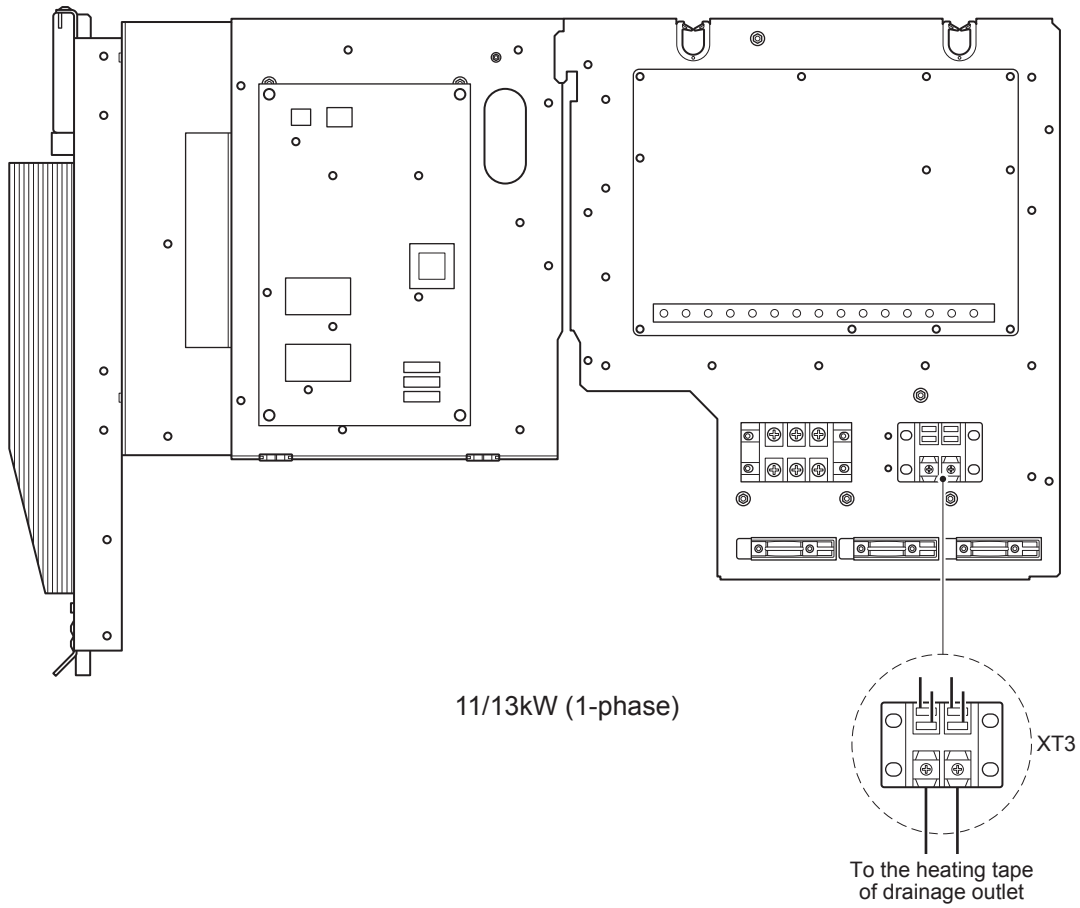

Fig. 140

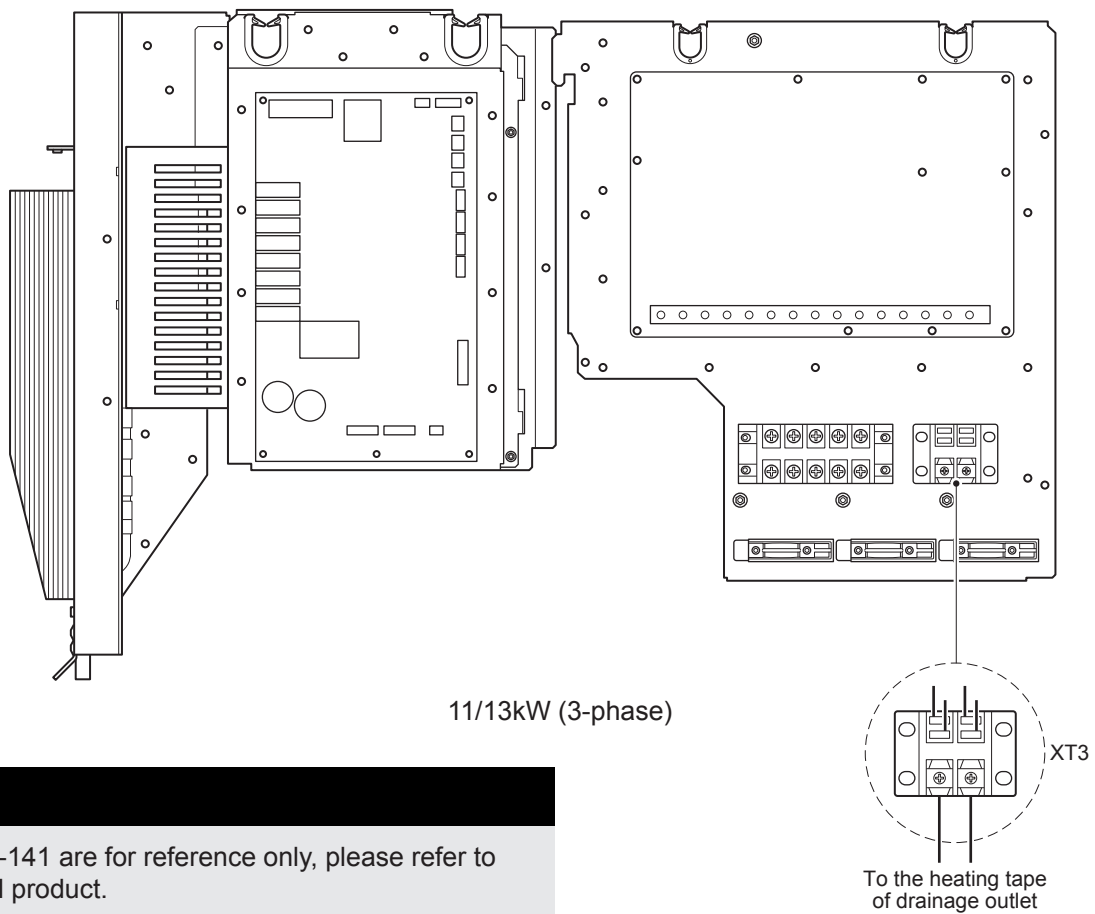

Fig. 141

NOTE

Figs. 138-141 are for reference only, please refer to the actual product.

The power of the E-heating tape shall not exceed 40W/200mA, supply voltage 230VAC.

Annex C:
Temperature sensor resistance
characteristics

Table 1: T4, T3, T2, T2B, Th sensor resistance characteristics

Temp. (°C)	Resistance (kΩ)	Temp. (°C)	Resistance (kΩ)	Temp. (°C)	Resistance (kΩ)	Temp. (°C)	Resistance (kΩ)
-25	144.266	15	16.079	55	2.841	95	0.708
-24	135.601	16	15.313	56	2.734	96	0.686
-23	127.507	17	14.588	57	2.632	97	0.666
-22	119.941	18	13.902	58	2.534	98	0.646
-21	112.867	19	13.251	59	2.44	99	0.627
-20	106.732	20	12.635	60	2.35	100	0.609
-19	100.552	21	12.05	61	2.264	101	0.591
-18	94.769	22	11.496	62	2.181	102	0.574
-17	89.353	23	10.971	63	2.102	103	0.558
-16	84.278	24	10.473	64	2.026	104	0.542
-15	79.521	25	10	65	1.953	105	0.527
-14	75.059	26	9.551	66	1.883		
-13	70.873	27	9.125	67	1.816		
-12	66.943	28	8.721	68	1.752		
-11	63.252	29	8.337	69	1.69		
-10	59.784	30	7.972	70	1.631		
-9	56.524	31	7.625	71	1.574		
-8	53.458	32	7.296	72	1.519		
-7	50.575	33	6.982	73	1.466		
-6	47.862	34	6.684	74	1.416		
-5	45.308	35	6.401	75	1.367		
-4	42.903	36	6.131	76	1.321		
-3	40.638	37	5.874	77	1.276		
-2	38.504	38	5.63	78	1.233		
-1	36.492	39	5.397	79	1.191		
0	34.596	40	5.175	80	1.151		
1	32.807	41	4.964	81	1.113		
2	31.12	42	4.763	82	1.076		
3	29.528	43	4.571	83	1.041		
4	28.026	44	4.387	84	1.007		
5	26.608	45	4.213	85	0.974		
6	25.268	46	4.046	86	0.942		
7	24.003	47	3.887	87	0.912		
8	22.808	48	3.735	88	0.883		
9	21.678	49	3.59	89	0.855		
10	20.61	50	3.451	90	0.828		
11	19.601	51	3.318	91	0.802		
12	18.646	52	3.191	92	0.777		
13	17.743	53	3.069	93	0.753		
14	16.888	54	2.952	94	0.73		

Table 2: Tp sensor resistance characteristics

Temp. (°C)	Resistance (kΩ)	Temp. (°C)	Resistance (kΩ)	Temp. (°C)	Resistance (kΩ)	Temp. (°C)	Resistance (kΩ)
-20	542.7	20	68.66	60	13.59	100	3.702
-19	511.9	21	65.62	61	13.11	101	3.595
-18	483.0	22	62.73	62	12.65	102	3.492
-17	455.9	23	59.98	63	12.21	103	3.392
-16	430.5	24	57.37	64	11.79	104	3.296
-15	406.7	25	54.89	65	11.38	105	3.203
-14	384.3	26	52.53	66	10.99	106	3.113
-13	363.3	27	50.28	67	10.61	107	3.025
-12	343.6	28	48.14	68	10.25	108	2.941
-11	325.1	29	46.11	69	9.902	109	2.860
-10	307.7	30	44.17	70	9.569	110	2.781
-9	291.3	31	42.33	71	9.248	111	2.704
-8	275.9	32	40.57	72	8.940	112	2.630
-7	261.4	33	38.89	73	8.643	113	2.559
-6	247.8	34	37.30	74	8.358	114	2.489
-5	234.9	35	35.78	75	8.084	115	2.422
-4	222.8	36	34.32	76	7.820	116	2.357
-3	211.4	37	32.94	77	7.566	117	2.294
-2	200.7	38	31.62	78	7.321	118	2.233
-1	190.5	39	30.36	79	7.086	119	2.174
0	180.9	40	29.15	80	6.859	120	2.117
1	171.9	41	28.00	81	6.641	121	2.061
2	163.3	42	26.90	82	6.430	122	2.007
3	155.2	43	25.86	83	6.228	123	1.955
4	147.6	44	24.85	84	6.033	124	1.905
5	140.4	45	23.89	85	5.844	125	1.856
6	133.5	46	22.89	86	5.663	126	1.808
7	127.1	47	22.10	87	5.488	127	1.762
8	121.0	48	21.26	88	5.320	128	1.717
9	115.2	49	20.46	89	5.157	129	1.674
10	109.8	50	19.69	90	5.000	130	1.632
11	104.6	51	18.96	91	4.849		
12	99.69	52	18.26	92	4.703		
13	95.05	53	17.58	93	4.562		
14	90.66	54	16.94	94	4.426		
15	86.49	55	16.32	95	4.294		
16	82.54	56	15.73	96	4.167		
17	78.79	57	15.16	97	4.045		
18	75.24	58	14.62	98	3.927		
19	71.86	59	14.09	99	3.812		

Table 3: T5, TW_out, TW_in, T1 temperature sensor resistance characteristics

Temp. (°C)	Resistance (kΩ)	Temp. (°C)	Resistance (kΩ)	Temp. (°C)	Resistance (kΩ)	Temp. (°C)	Resistance (kΩ)
-30	867.29	10	98.227	50	17.600	90	4.4381
-29	815.80	11	93.634	51	16.943	91	4.3022
-28	767.68	12	89.278	52	16.315	92	4.1711
-27	722.68	13	85.146	53	15.713	93	4.0446
-26	680.54	14	81.225	54	15.136	94	3.9225
-25	641.07	15	77.504	55	14.583	95	3.8046
-24	604.08	16	73.972	56	14.054	96	3.6908
-23	569.39	17	70.619	57	13.546	97	3.5810
-22	536.85	18	67.434	58	13.059	98	3.4748
-21	506.33	19	64.409	59	12.592	99	3.3724
-20	477.69	20	61.535	60	12.144	100	3.2734
-19	450.81	21	58.804	61	11.715	101	3.1777
-18	425.59	22	56.209	62	11.302	102	3.0853
-17	401.91	23	53.742	63	10.906	103	2.9960
-16	379.69	24	51.396	64	10.526	104	2.9096
-15	358.83	25	49.165	65	10.161	105	2.8262
-14	339.24	26	47.043	66	9.8105		
-13	320.85	27	45.025	67	9.4736		
-12	303.56	28	43.104	68	9.1498		
-11	287.33	29	41.276	69	8.8387		
-10	272.06	30	39.535	70	8.5396		
-9	257.71	31	37.878	71	8.2520		
-8	244.21	32	36.299	72	7.9755		
-7	231.51	33	34.796	73	7.7094		
-6	219.55	34	33.363	74	7.4536		
-5	208.28	35	31.977	75	7.2073		
-4	197.67	36	30.695	76	6.9704		
-3	187.66	37	29.453	77	6.7423		
-2	178.22	38	28.269	78	6.5228		
-1	168.31	39	27.139	79	6.3114		
0	160.90	40	26.061	80	6.1078		
1	152.96	41	25.031	81	5.9117		
2	145.45	42	24.048	82	5.7228		
3	138.35	43	23.109	83	5.5409		
4	131.64	44	22.212	84	5.3655		
5	125.28	45	21.355	85	5.1965		
6	119.27	46	20.536	86	5.0336		
7	113.58	47	19.752	87	4.8765		
8	108.18	48	19.003	88	4.7251		
9	103.07	49	18.286	89	4.5790		

Benchmark Commissioning & Warranty Validation Service Record for the United Kingdom

It is a requirement that the heat pump is installed and commissioned to the manufacturers' instructions and the data fields on the commissioning checklist completed in full.

To instigate the warranty the heat pump needs to be registered with the manufacturer within one month of the installation. The warranty rests with the end-user (consumer), and they should be made aware it is ultimately their responsibility to register with the manufacturer, within the allotted time period.

It is essential that the heat pump is serviced in line with the manufacturers' recommendations, at least annually. This must be carried out by a competent, certified operative. The service details should be recorded on the Benchmark Service and Interim Heat Pump Work Record and left with the householder. Failure to comply with the manufacturers' servicing instructions and requirements will invalidate the warranty.



www.hhic.co.uk

This Commissioning Checklist is to be completed in full by the competent person who commissioned the heat pump and associated equipment as a means of demonstrating compliance with the appropriate Building Regulations and then handed to the customer to keep for future reference.

Failure to install and commission according to the manufacturers' instructions and complete this Benchmark Commissioning Checklist will invalidate the warranty. This does not affect the customer's statutory rights.

* All installations in England and Wales must be notified to Local Authority Building Control (LABC) either directly or through a Competent Persons Scheme. A Building Regulations Compliance Certificate will then be issued to the customer.

© Heating and Hotwater Industry Council (HHIC)



www.centralheating.co.uk

AIR TO WATER HEAT PUMP COMMISSIONING CHECKLIST

Address:											
Heat Pump make and model:											
Heat Pump serial number:											
Commissioned by (PRINT NAME):						Certified Operative Reg number (1)					
Company name:						Telephone number:					
Company email:						Company address:					
										Commissioning date:	
Heating and hot water system complies with the appropriate Building Regulations?										Yes	
DNO notification?										Yes	
Building Regulations Notification Number (if applicable)											
MCS installer registration Number (if applicable)						MCS product certification number (if applicable)					
F-gas certification number (split heat pump only)											
G3 certification number (if applicable)											
Heat Pump Type (Tick)		Split		Monoblock		Peak heat loss of building kW					
Is Heat Pump Installed as part of a cascade?		Yes		Cascade Heat Pump Series						() of ()	
Heat Pump Refrigerant Type		Refrigerant weight						kg			
Electrical and Hydronic Controls – SYSTEM AND HEAT PUMP (Tick the appropriate boxes)											
Time and temperature control to heating		Room thermostat and programmer/timer				Programmable Roomstat					
		Load/weather compensation				Optimum start control					
Time and temperature control to hot water		Cylinder thermostat and programmer/timer				Combined with Heat pump main controls					
Hybrid system – synchronised control of boiler and heat pump fitted										Yes	
If Yes – boiler model switching point – (Quote Tariff or Temperature Level)											
Heating zone valves (including under floor loops)		pre-existing		Fitted		Not required					
Hot water zone valves		pre-existing		Fitted		Not required					
Thermostatic radiator valves		pre-existing		Fitted		Not required					
Outdoor Sensor		pre-existing		Fitted		Not required					
Heat Pump Safety Interlock (3)		pre-existing		Fitted		Not required					
Automatic bypass to system		pre-existing		Fitted		Not required					
Buffer vessel Fitted		Yes		No		If yes volume:				Litres	
Plate Heat Exchanger fitted to give hydronic separation of the heat pump circuit to the heating circuit										Yes	
Expansion vessel for heating is sized, fitted & charged in accordance with manufacture's instructions										Yes	
Legionella protection for stored hot water provided by timed temperature control?										Yes	
Water Treatment – SYSTEM AND HEAT PUMP (Tick the appropriate boxes/Measure and Record)											
The system has been flushed/cleaned and a suitable inhibitor applied upon final fill in accordance with BS7593 and manufacturers instruction										Yes	
What system cleaner was used?		Brand:				Product:					
What heating system inhibitor was used?		Brand:				Product:					
What heating system inhibitor was used?		pre-existing		Fitted		Not required					
What heat pump system anti-freeze/inhibitor was used?		Brand:		Product:		% concentration					
Is the heating system adequately frost protected and pipes insulated to prevent heat loss?										Yes	
Heat Pump outdoor unit (Tick the appropriate boxes/Measure and Record)											
Split only: The refrigerant circuit has been evacuated and charged in accordance with manufacturer's instructions										Yes	
The heat pump is fitted on a solid/stable surface capable of taking its weight										Yes	
The necessary heat pump defrost provision been put in place										Yes	
The heat pump fan free from obstacles and operational										Yes	
Condensate drain installed to manufacturer's instructions										Yes	
CENTRAL HEATING MODE (Tick the appropriate boxes/Measure and Record)											
The heating system has been filled and pressure tested										Yes	
Heating Flow Temperature		°C		Heating Return Temperature						°C	
System correctly balance/rebalanced										Yes	
DOMESTIC HOT WATER MODE (Tick the appropriate boxes)											
Is the heat pump connected to a hot water cylinder?		Unvented		Vented		Thermal Store		Not connected			
Hot water cylinder size		Litres		Stored hot water temperature						°C	
Hot water has been checked at all outlets		Yes		Have Thermostatic Blending Valves been fitted?				Yes		Not required	

* All installations in England and Wales must be notified to Local Authority Building Control (LABC) either directly or through a Competent Persons Scheme. A Building Regulations Compliance Certificate will then be issued to the customer.

© Heating and Hotwater Industry Council (HHIC)



www.centralheating.co.uk

ADDITIONAL SYSTEM INFORMATION (Tick the appropriate boxes/Measure and Record)											
Water flow rate setting of the heat pump at commissioning (l/min)											
Additional heat sources connected:	<input type="checkbox"/>	Gas Boiler	<input type="checkbox"/>	Oil Boiler	<input type="checkbox"/>	Electric Heater	<input type="checkbox"/>	Solar Thermal	<input type="checkbox"/>	Other:	
ALL INSTALLATIONS											
All electrical work complies with the appropriate Regulations										Yes	<input type="checkbox"/>
The heat pump and associated products have been installed and commissioned in accordance with the manufacturer's instructions										Yes	<input type="checkbox"/>
The operation of the heat pump and system controls have been demonstrated to and understood by the customer										Yes	<input type="checkbox"/>
The manufacturer's literature, including Benchmark Checklist and Service Record, has been explained and left with the customer										Yes	<input type="checkbox"/>
Commissioning Engineer's signature:											
Customer's signature (To confirm satisfactory demonstration and receipt of manufacturers literature)											

* All installations in England and Wales must be notified to Local Authority Building Control (LABC) either directly or through a Competent Persons Scheme. A Building Regulations Compliance Certificate will then be issued to the customer.

© Heating and Hotwater Industry Council (HHIC)



www.centralheating.co.uk

Notes :

Notes :

A large, empty rectangular box with a thin black border, occupying most of the page below the 'Notes:' header. It is intended for the user to write their notes.

Notes :

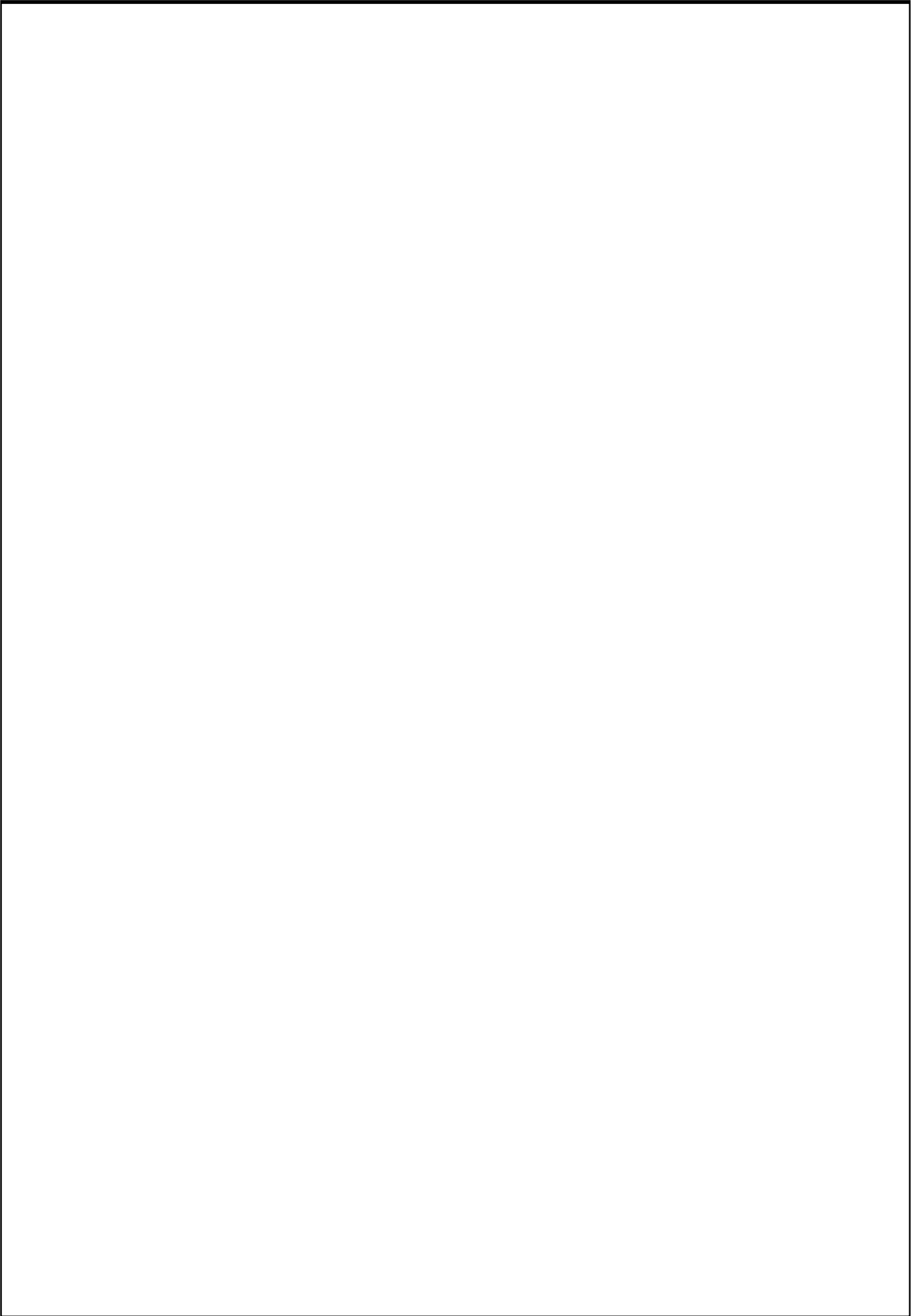
A large, empty rectangular box with a black border, intended for taking notes. It occupies the majority of the page below the 'Notes :' header.



Baxi
Brooks House,
Coventry Road,
Warwick, CV34 4LL

CE
0085



Please ensure the boiler is installed in accordance with these installation instructions and that you adhere to the Building Regulations.

e&oe

All descriptions and illustrations provided in this document have been carefully prepared but we reserve the right to make changes and improvements in our products which may affect the accuracy of the information contained in this leaflet. All goods are sold subject to our standard Conditions of Sale which are available on request.

BAXI