



# PE-STEPB Technical Sheet



PE-STEPB steps are suitable for fitting into new and existing brickwork. They are made from virgin polypropylene copolymer plastic, encapsulating galvanised steel. The galvanised steel and virgin copolymer plastic offer excellent corrosion resistance and a bright, non-slip surface for safety. The steel is partially exposed to make fixing easier between courses of brick. Once fixed, the galvanised steel portion is encased in the wall of the chamber. A stainless steel version is also available for highly corrosive environments.

PE-STEPB are manufactured and tested in accordance with BS EN 13101 and are Kitemarked by BSI. They are also CE Marked.

## Fitting to New Brickwork

1. The steps are designed to suit the joints between the bricks.
2. Double steps will fit between a full brick and one cut just less than half a brick or in the horizontal gap.
3. Insert a step every three to four courses of bricks depending on the size of brick and application.
4. Vertical joints need to be at 320mm for double steps.

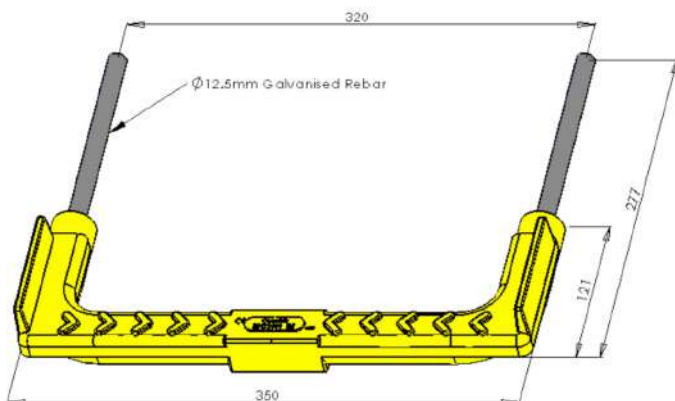

## Fitting to Existing Structure

1. Drill two 14mm diameter holes parallel and 320mm apart at least 150mm deep.
2. Apply an epoxy grout or suitable cementitious grout to the tails and push into the holes.

