

### Installation Recommendations

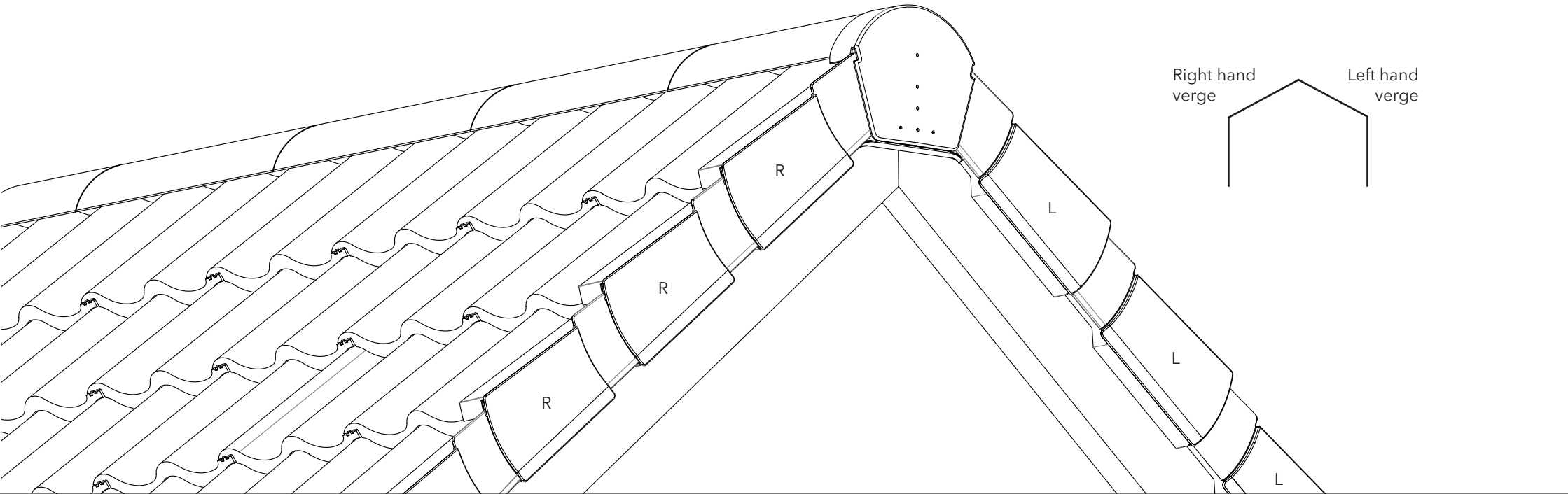

### Interlocking Dry Verge Components

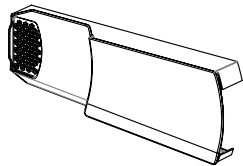

Dry Verge Unit  
(Code: HD IDV/L)  
10 per pack

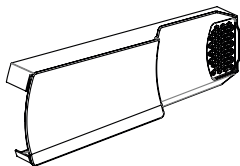

Dry Verge Unit  
(Code: HD IDV/R)  
10 per pack

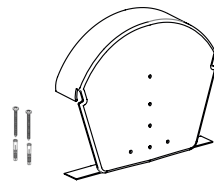

Half Round End Cap  
(Code: HD IDV/HR)  
2 per pack

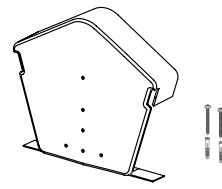

Angle Ridge End Cap  
(Code: HD IDV/AR)  
2 per pack

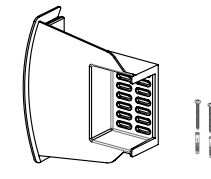

Starter Unit Kit  
(Code: HD IDV/ST+)  
2 per pack

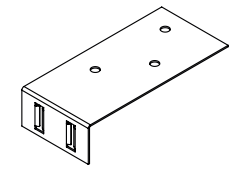

Batten End Clip  
(Code: HD IDV/BC)  
10 per pack



## Installation Recommendations

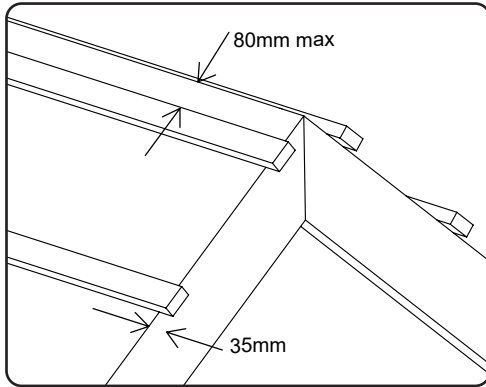

1. The tile battens should be fixed as required with a 35mm overhang beyond the face of the masonry or barge board creating a gap of 5mm or so between the verge unit and the wall or barge board. The distance between the apex and the top batten should not exceed 80mm. The underlay should be trimmed to extend 5mm beyond the ends of the battens.

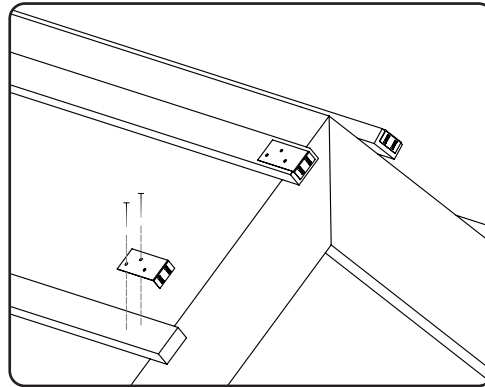

2. It is recommended that batten end clips (code: HD IDV/BC) or a suitable screw should be used at the batten ends to provide long term secure fixing and wind load resistance to comply with BS 8612. One clip should be nailed twice to the top of each batten with the short flange in contact with the batten end.

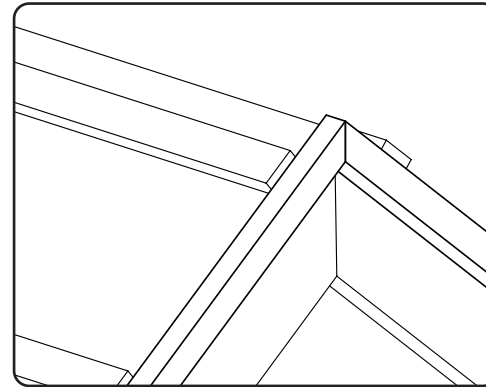

3. For refurbishment installations where the batten end clip cannot be fixed without removing the tiles, or where the batten ends are not exposed or have decayed, fix a 35mm or 38mm thick continuous batten along the length of the verge to provide an alternative fixing for the verge units. Fixing into or with mortar is not recommended.

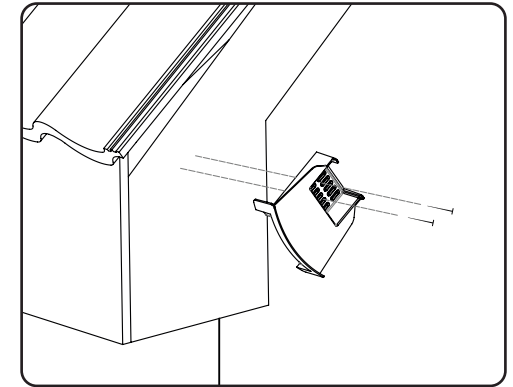

4. The verge starter unit (code: HD IDV/ST+) should be fixed securely at the eaves through the slots using the 2 x 25mm flange head screws provided into the barge board or masonry. The starter unit is most easily marked for position by fitting to a verge unit and placing the verge unit onto the eaves tile.

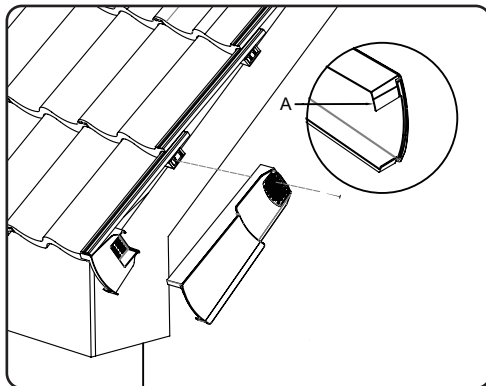

5. Next, clip the first verge unit onto the starter unit; this will require the flange tab A on the first verge unit to be snapped off at the break line. Once firmly clipped to the starter unit, the verge unit can then be nailed or screwed through one of the holes provided into the batten end or continuous batten. Where the batten end clip is used, the nail should penetrate one of the slots provided.

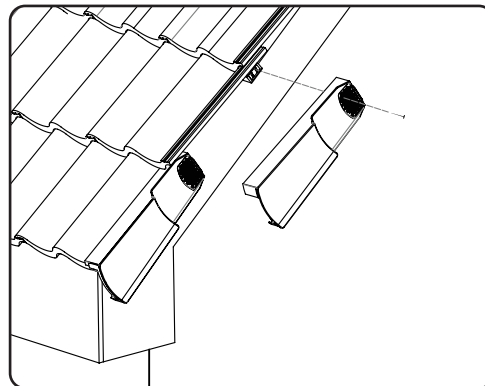

6. Subsequent units are fitted in the same way, clipping each verge unit over the previously fixed unit up to the ridge ensuring that the verge unit is pushed up-slope to fit snugly onto the tile. A small gap of a few millimetres should be maintained between the underside of the dry verge units and the masonry or barge board.

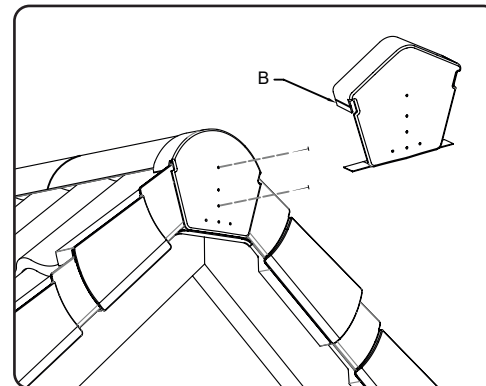

7. The half-round ridge edge cap (code: HD IDV/HR) or universal angle ridge end cap (code: HD IDV/AR) should be fitted to the ridge tile, interlocking with the verge units and then fixed into the barge board or masonry through the build holes using the two 65mm screws provided. For shallow angle ridge tiles, the angle ridge end cap incorporates snap-out tabs (B) for an improved fit.

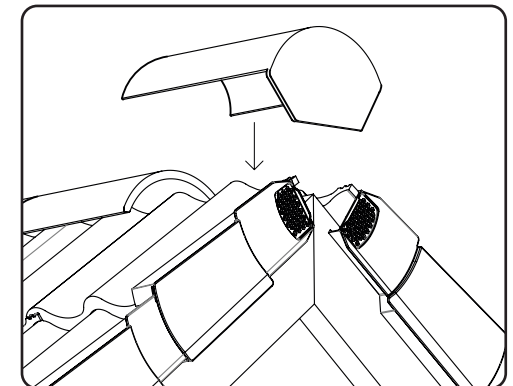

8. Alternatively, a block end ridge tile may be used to complete the installation, fitted in accordance with manufacturer's recommendations.

