

Before assembly

- We recommend that time is taken to read the instructions before starting assembly, then follow the easy step by step guide. The instruction sheet is only a guide to the assembly. Certain items may not be shown to scale.
- Check all components prior to assembly
- This product should be assembled by no less than two people.
- Never attempt to erect the assembly in high winds.
- Drill components where indicated.

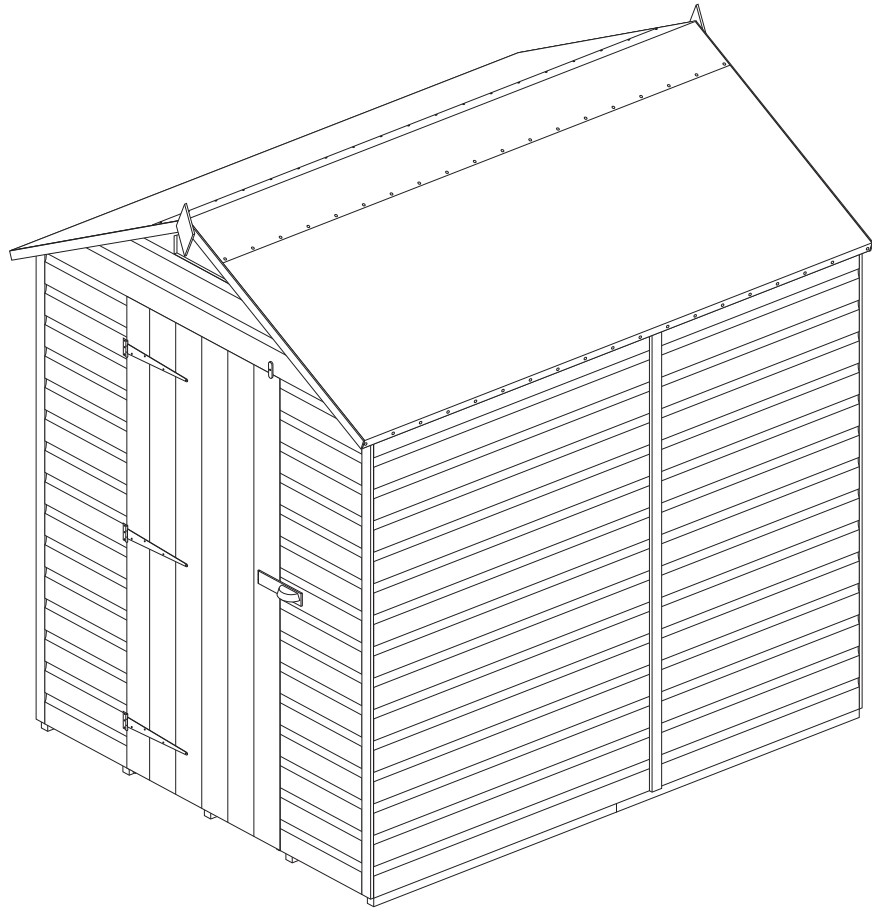

Recommended tools for assembly

- Cross head screw driver
- 10mm spanner
- Hammer
- Sharp knife
- Drill
- 4mm diameter drill bit
- 6mm diameter drill bit
- Spirit level
- Silicon sealant
- Step ladder

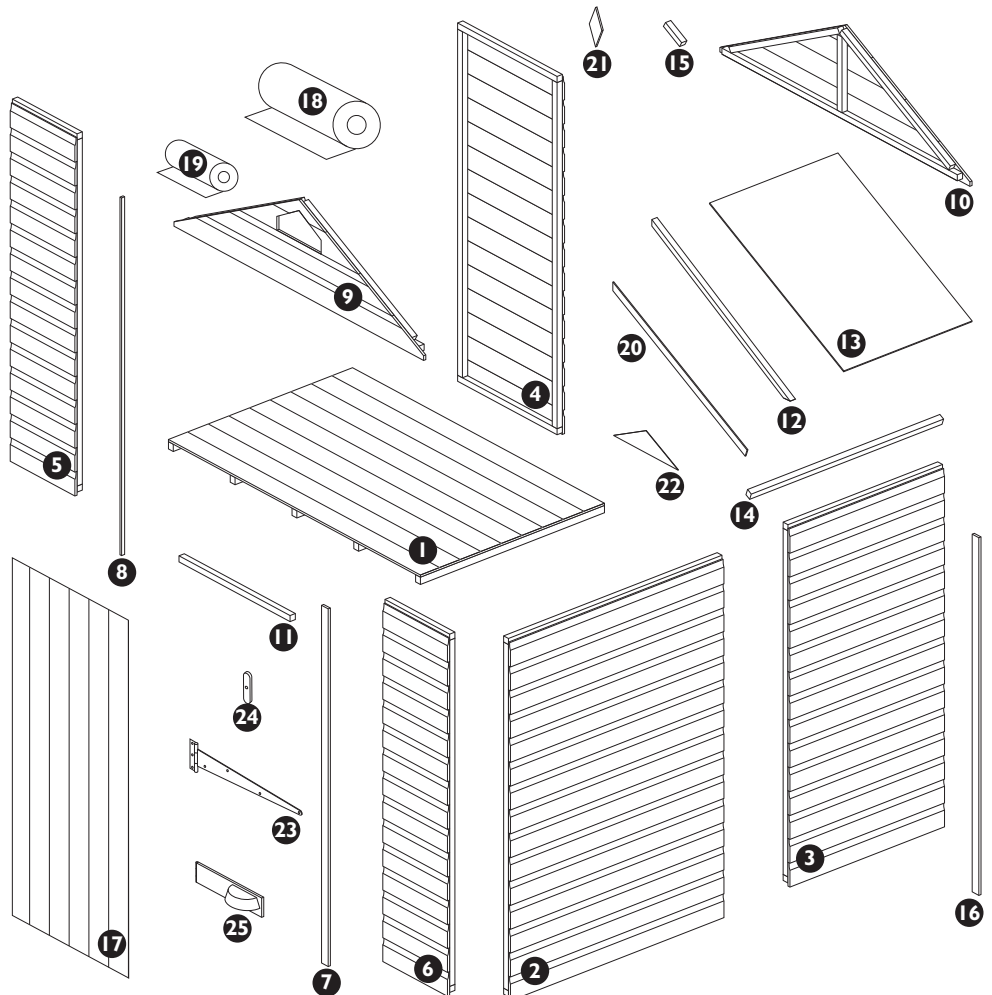

No.	Components	Qty.
1	Floor	2
2	Large plain panel (Width 1174mm)	2
3	Medium plain panel (Width 850mm)	3
4	Small plain panel (Width 600mm)	1
5	Front panel (Door hinge side)	1
6	Front panel (Padlock protector support rail)	1
7	Door rebate strip (12 x 40 x 1685mm)	1
8	Door rebate strip (12 x 28 x 1685mm)	1
9	Front apex panel (with window)	1
10	Rear apex panel	1
11	Door header rail (35 x 29 x 670mm)	1
12	Roof rafters	8
13	Roof panels	6
14	Felt battens (29 x 29 x 1057mm)	4
15	Felt batten block	4
16	Coverstrips (12 x 47 x 1710mm)	7
17	Door	1
18	Roofing felt (5m)	1
19	Roofing ridge felt (2.5m)	1
20	Bargeboards	4

No.	Fixing Kit	Qty.
21	Finials	2
22	Roof gussets	4
23	T-hinges	3
24	Turn button	1
25	Padlock protector kit	1
26	65mm coach bolts	2
27	50mm coach bolts	6
28	6mm washer	8
29	6mm nut	8
30	63mm screws	14
31	50mm screws	35
32	38mm screws	16
33	32mm security screws	21
34	25mm screws	11
35	30mm nails	105
36	10mm felt nails	112



1. Lay floor sections

Prepare a firm level area for the shed to sit. Position the two floor sections together and ensure level.

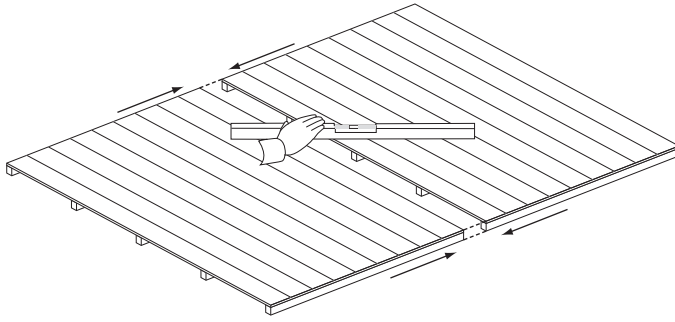

Important note

To "VALIDATE" the guarantee, adequate provision must be made to ensure ground contact is avoided and air is able to circulate underneath the building.

Placing the building on a concrete pad or slab base is acceptable provided that the building is not allowed to sit in pooled water during wet conditions.

If the building is to sit on soil or grass it **MUST** be erected on pressure treated wooden 50mm x 50mm or similar bearers (**These are not supplied in the kit**).

Rowlinson Garden Products recommend using pressure treated bearers with all buildings on any type of base.

2. Wall panels

Position two medium panels as shown. Note how the panel frames sit on the floor with the panel cladding overhanging the floor edge. Ensure square and secure using 3 x 50mm screws, screw through the frame of the back panel, into the frame of the side panel. Continue to add panels as shown below securing each one with 3 x 50mm screws.



Drill

It is recommended to drill pilot holes with a 3mm drill for each screw.

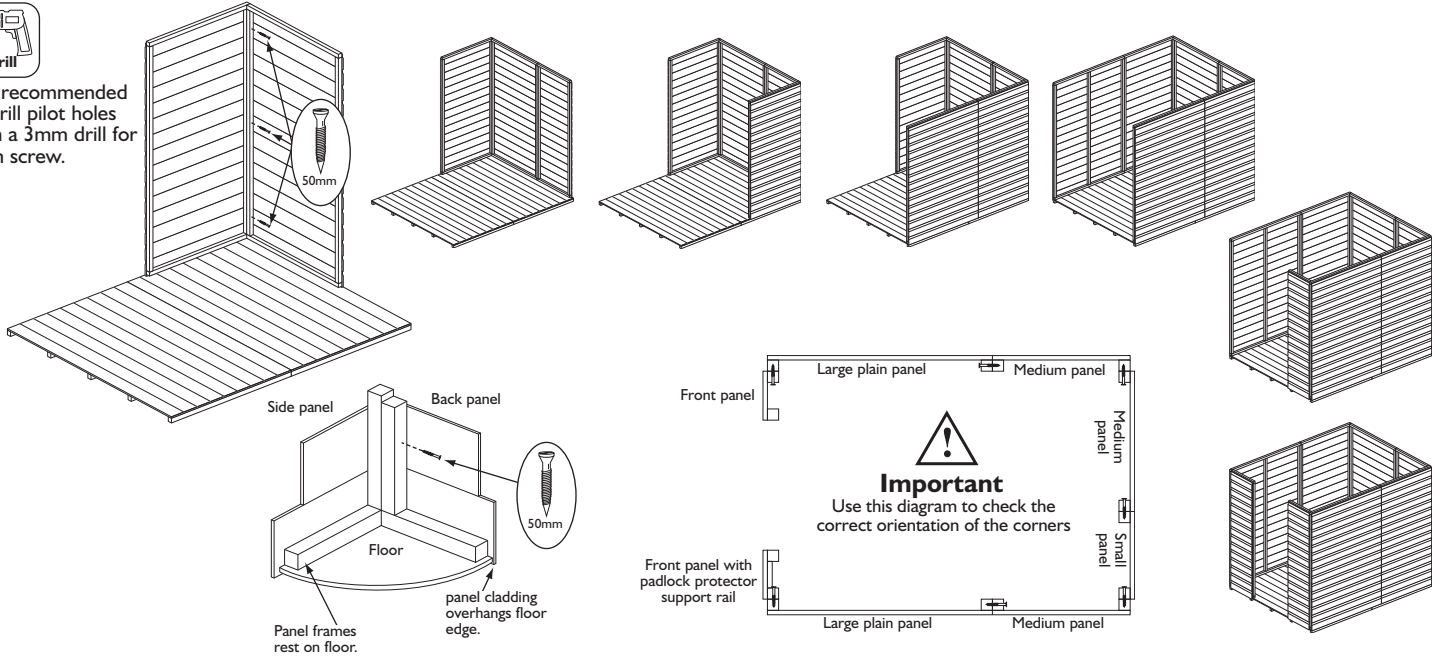

3. Apex panels and door header rail

Place an apex panel on top of the back panel, make sure the bottom shiplap board of the apex panel fits correctly into the shiplap board of the back panel. Secure by using 2 x 50mm screws, screw up through the top frame of the back panel into the bottom frame of the apex panel. Repeat for front apex. Attach to the front apex the door header rail using 2 x 50mm screws. Secure it flush to the bottom of the apex framing as shown.



Drill

It is recommended to drill pilot holes with a 3mm drill for each screw in this section.

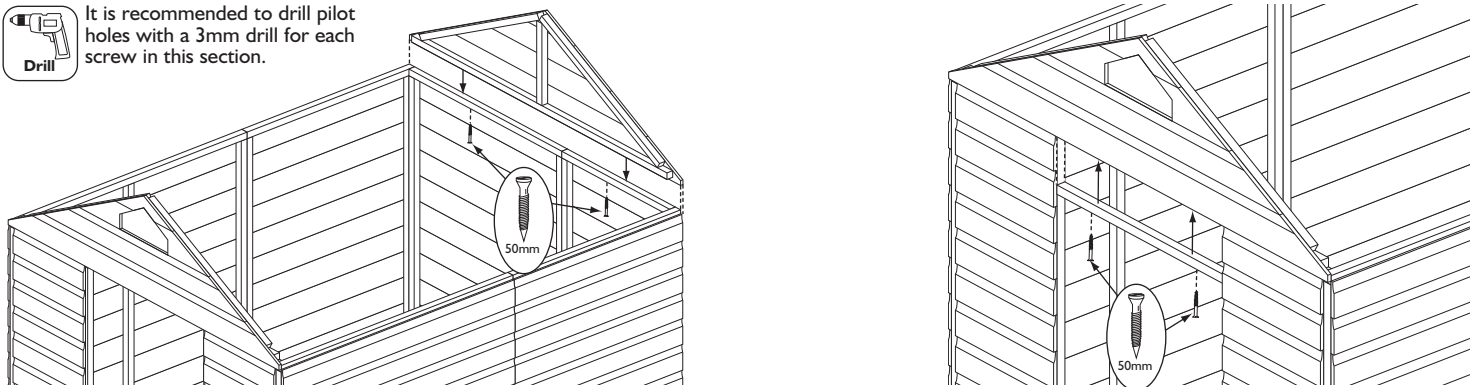

4. Securing the walls to the floor

Ensure the panels are sitting square on the floor. Secure using 14 x 63mm screws, screw through the panel frames and floor into the floor joists.



Drill

It is recommended to drill pilot holes with a 3mm drill for each screw in this section.

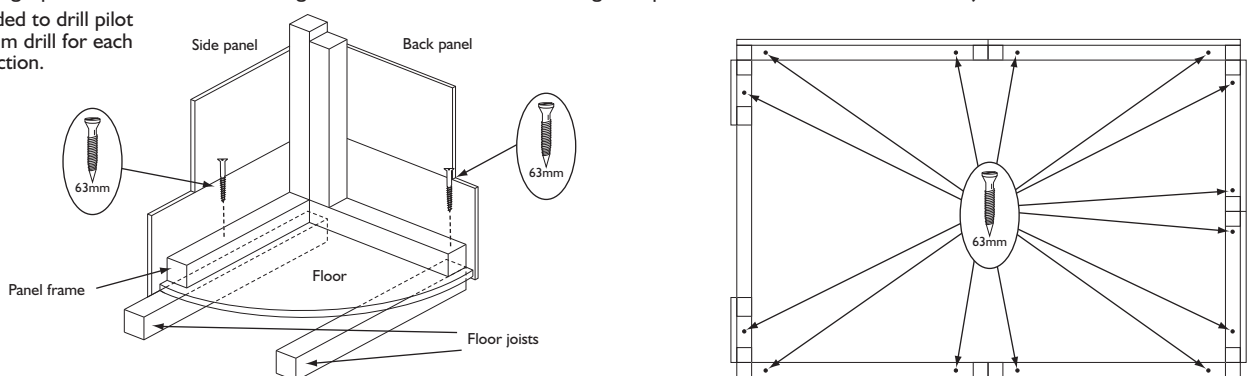

5. Door rebate coverstrips

To the door hinge side front panel, position the 12x28x1685mm door rebate coverstrip between the floor and the header rail and attach to the side of the panel frame using 5 x 25mm screws. To the other front panel, attach the rebate strip to the back of the panel using 5 x 25mm screws leaving a 12mm overlap. See diagram below.

View from inside the building.



It is recommended to drill pilot holes with a 3mm drill for each screw.

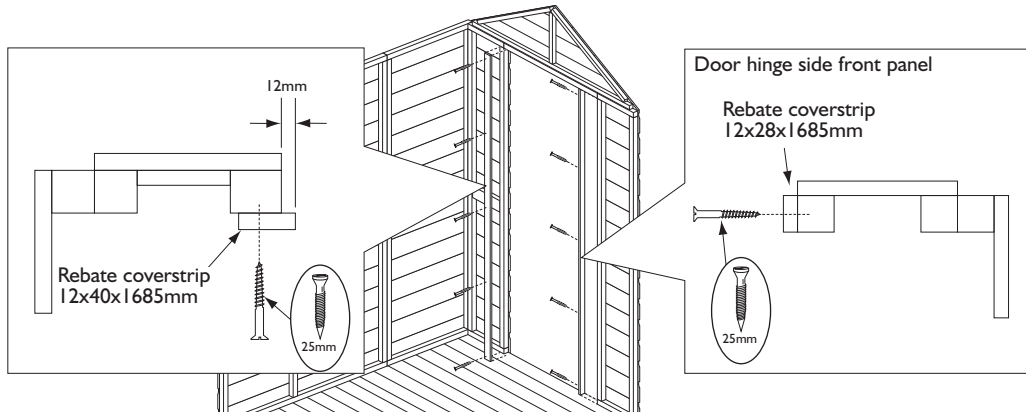

6. Roof panel assembly

To the first roof panel secure a roof rafter flush to the right-hand edge of the panel, ensure the correct angled end of the rafter is flush to the short edge of the panel as shown below. Attach using 4 x 30mm nails, nail through the panel into the rafter. To the second panel attach two rafters in the same way as the first with one down each side of the panel. To the third panel attach a rafter down the Left-hand edge. Join the three panels together using 2 x 50mm screws per joint. Screw through the rafter of one panel into the rafter of the next as shown. Create a second roof section in the same way as the first

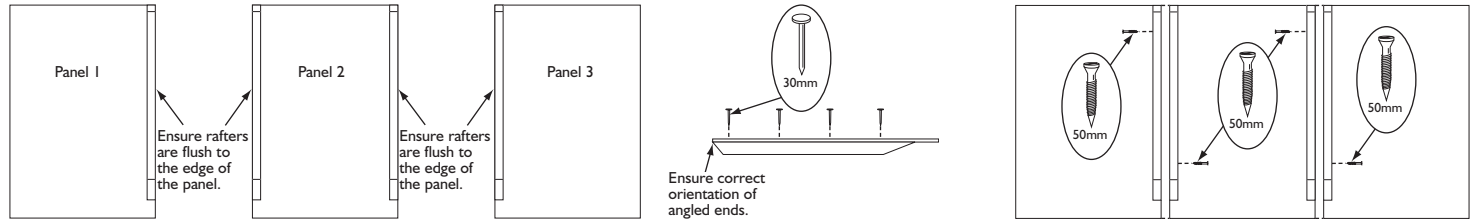

7. Fitting roof panels and gussets

Secure to the lower edge of both roof sections two felt battens using 5 x 30mm nails per batten as shown. Ensure the felt battens are flush to the edges of the panels. Flush to the front edges of each section attach the roof batten blocks evenly spaced along the edge using 2 x 30mm nails per block. Position the roof panels onto the building, make sure the top edges are located at the apex and the roof is flush with the back apex. Secure with 8 x 38mm screws per roof section, screw through the roof and into the panel framing. From inside the building fix a gusset to both sides of the two rafters using 2 x 30mm nails per gusset.

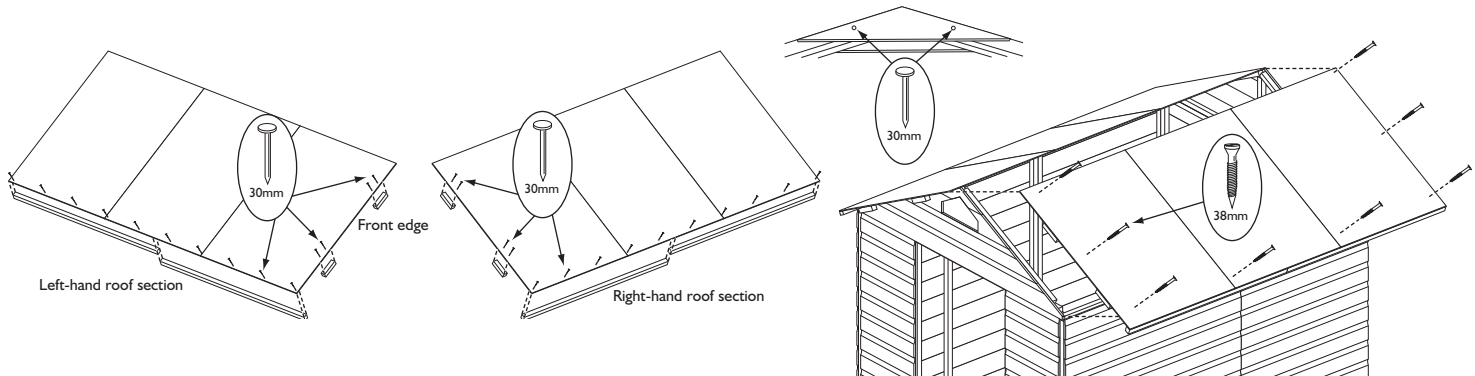

8. Roofing felt

Cut the 5m roofing felt roll into two equal lengths. Place one length over one roof section. At the front and along the lower edge of the roof leave an overhang of felt of at least 45mm. Fold down the felt along the lower edge and secure to the felt batten using 22 x 10mm felt nails evenly spaced. Tension the felt over the roof and secure along the upper edge using 4 x 10mm felt nails. Repeat this for the second piece of felt on the other half of the roof. Once the two pieces of felt are in place take the 2.5m ridge felt roll and place over the apex of the roof making sure it sits centrally over the roof ridge and overlaps the other two felt pieces, attach using 22 x 10mm felt nails evenly spaced, along each lower edge of the third felt. Dress down the ends of all felt pieces and attach to the Batten blocks at the front with 6 x 10mm felt nails. At the back secure to the apex panel using 6 x 10mm felt nails. when all the felt is in position trim any excess.

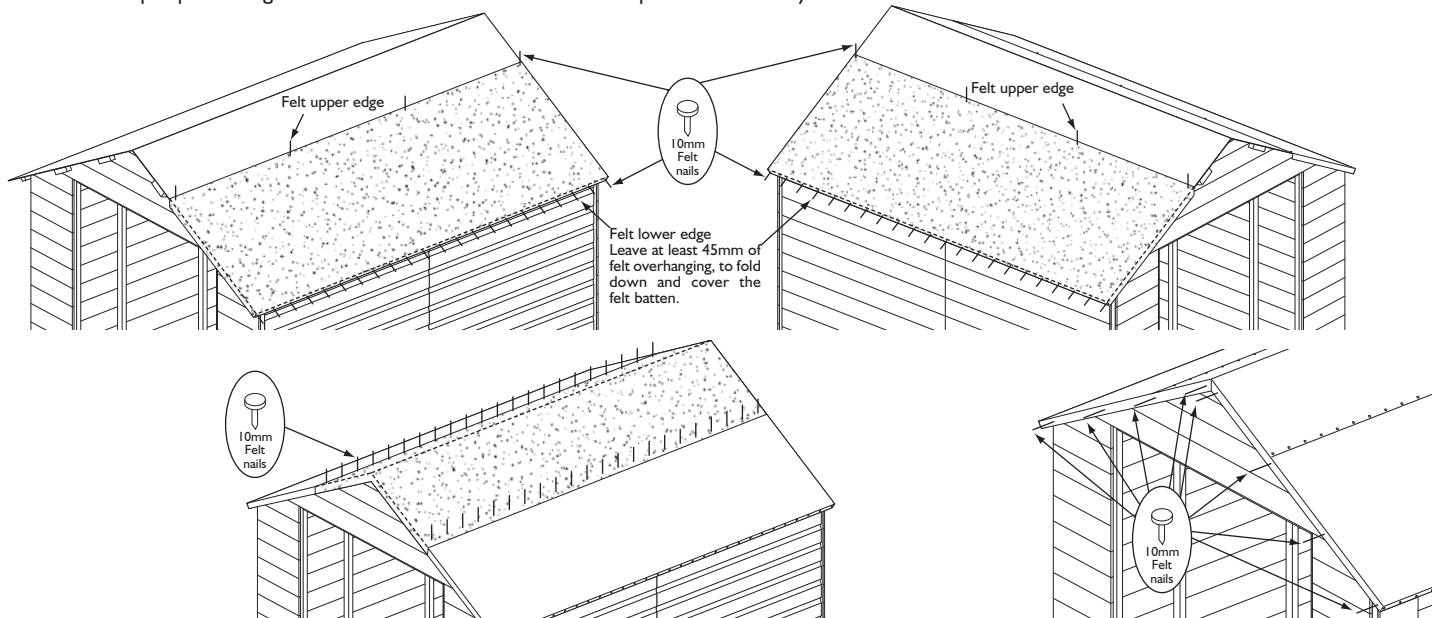

9. Fitting the door

Position the door in the opening and secure in place with three T-hinges and 7 x 32mm security screws per hinge as shown below. Fit the padlock protector to the outside of the door in line with the centre cross rail on the inside of the door, secure in place using 4 x 50mm coach bolts, nuts and washers. It will be necessary to drill holes for the coach bolts using a 6mm diameter drill bit. Fit the catch plate to the right-hand front panel using 2 x 65mm and 2 x 50mm coach bolts, nuts and washers, as shown below. Position the turn button near the top of the door and secure to the right-hand front panel using 1 x 25mm screw.

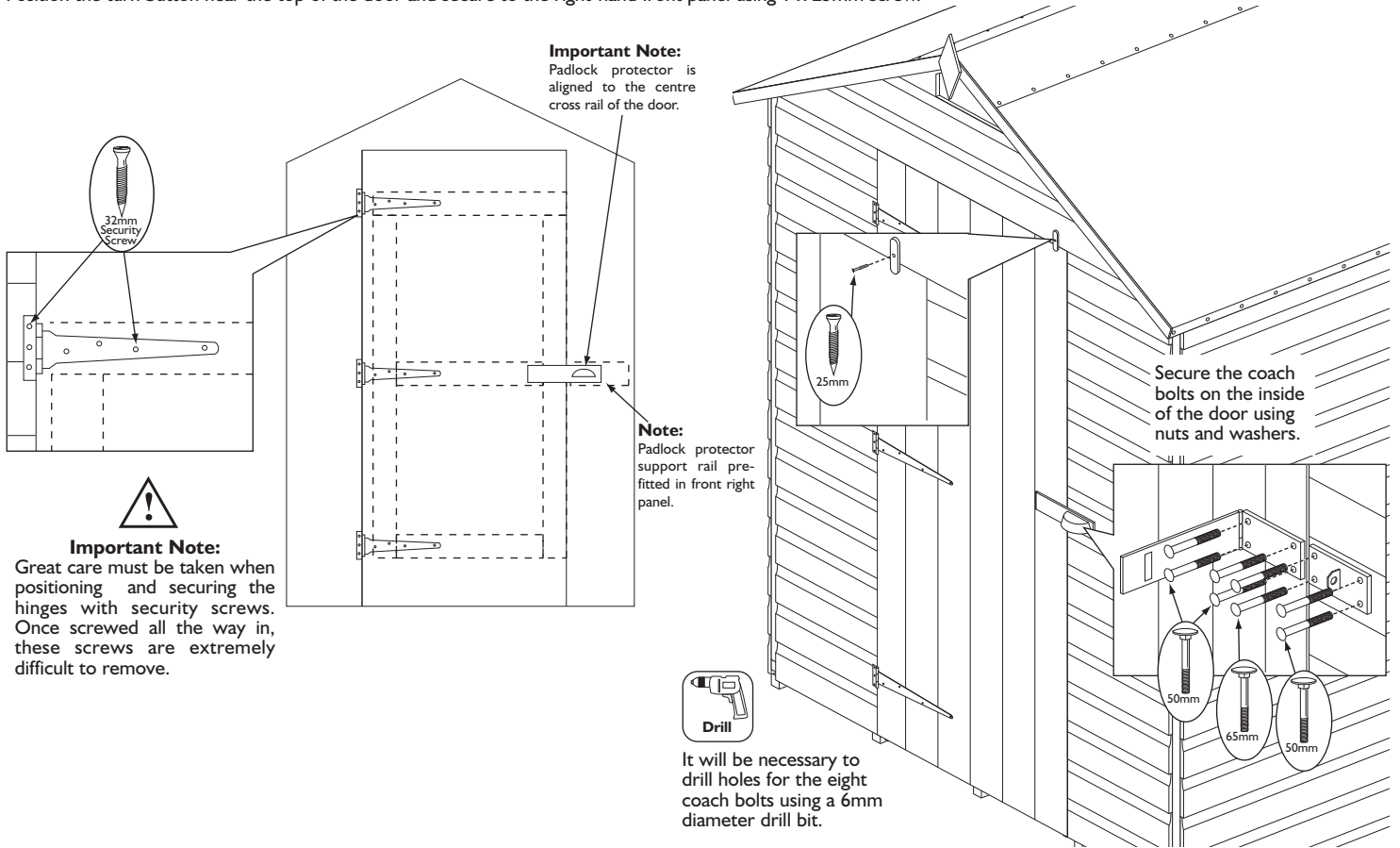

10. Coverstrips, bargeboards and finials

Fit a coverstrip into each corner, attach using 3 x 30mm nails per strip. The remaining three are used to cover the panel joins on each side and the back, attach using 3 x 30mm nails per strip. Attach bargeboards at the front so that the top edge is flush with the roof line and the two boards meet evenly in the middle secure using 3 x 30mm nails per board. Attach a finial centrally over the join between the bargeboards use 2 x 30mm nails. In the same way fit two bargeboards and a finial to the back.

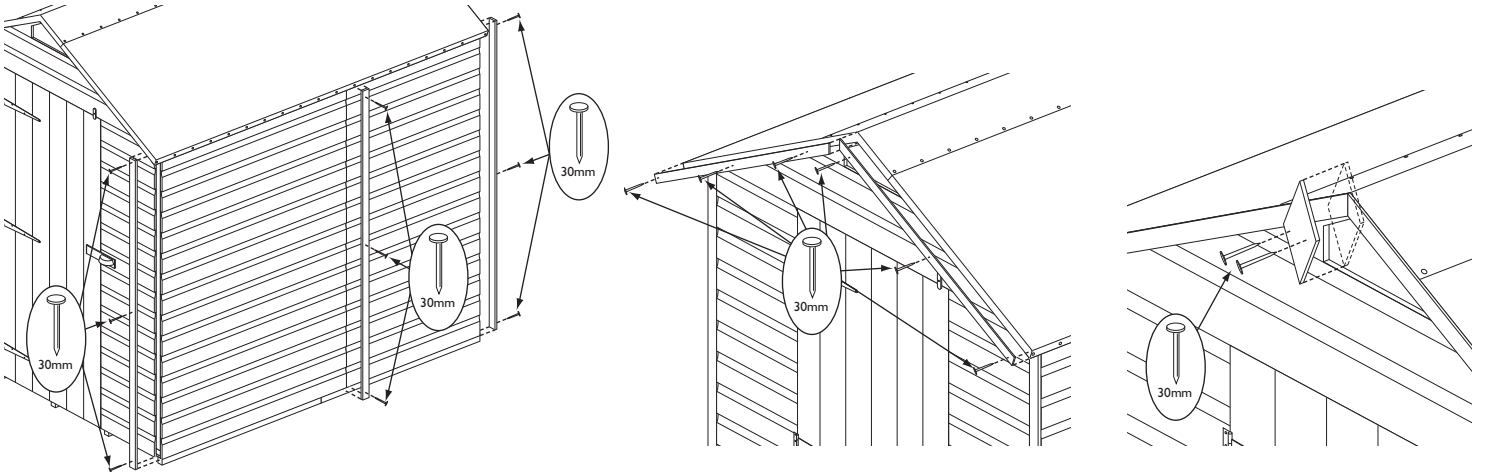

Important information - retain for future reference

Shiplap buildings come ready stained but this is only a preparatory treatment. To **VALIDATE** the guarantee, the building must be properly treated with a recognised external wood preserver **WITHIN 3 MONTHS** of assembly and **RE-TREATED ANNUALLY** thereafter.

Adequate provision must be made to ensure ground contact is avoided and air is able to circulate underneath the building. Placing the building on a concrete pad or slab base is acceptable provided that the building is not allowed to sit in pooled water during wet conditions. If the building is to sit on soil or grass it **MUST** be erected on pressure treated wooden 50mm x 50mm or similar bearers (**These are not supplied in the kit**). Rowlinson Garden Products recommend using pressure treated bearers with all buildings on any type of base.

Timber Information.

As timber is a natural material, there are certain weather conditions that may affect the materials properties. In times of excessive dry spells the material may lose some of its internal moisture causing a certain degree of shrinkage on a panel and in periods of excessive rain there will be a certain amount of swelling throughout the wooden panels. This process can not be avoided. If you have problems with certain boards shrinking in dry spells try to decrease the amount of direct sunlight on the building or the amount of air passing over the building. During hot spells spray water directly onto the panels with the aid of a garden hose.

If in doubt of any aspect regarding the assembly, use or safety of your building please contact us :

Help Line: (Normal Office Hours) 01829 261 121

Email: support@rowgar.co.uk

ROWLINSON GARDEN PRODUCTS LIMITED
Green Lane
Wardle Nr. Nantwich
Cheshire
CW5 6BN
www.rowgar.co.uk

We constantly improve the quality of our products, occasionally the components may differ from the components shown and are only correct at time of printing. We reserve the right to change the specification of our products without prior notice.

2015 © Rowlinson Garden Products Ltd