

Soprema UK Limited

Lady Lane Industrial Estate
Hadleigh
Ipswich
Suffolk IP7 6BA

Tel: 0330 058 0668

e-mail: info@soprema.co.uk

website: www.soprema.co.uk



Agrément Certificate

24/7312

Product Sheet 1 Issue 1

SOPRATHERM INSULATION

SOPRATHERM CW4000 PIR INSULATION FOR PARTIAL FILL CAVITY WALLS

This Agrément Certificate Product Sheet⁽¹⁾ relates to SOPRATHERM CW4000 PIR Insulation For Partial Fill Cavity Walls, a rigid polyisocyanurate (PIR) board faced on both sides with low emissivity facings, for use as partial fill insulation (with a minimum 50 mm residual cavity) in new external cavity walls with masonry inner and outer leaves, in domestic and non-domestic buildings; additional requirements apply for buildings above 12 m in height and further restrictions may apply based on the reaction to fire performance.

(1) Hereinafter referred to as 'Certificate'.

The assessment includes

Product factors:

- compliance with Building Regulations
- compliance with additional regulatory or non-regulatory information where applicable
- evaluation against technical specifications
- assessment criteria and technical investigations
- uses and design considerations

Process factors:

- compliance with Scheme requirements
- installation, delivery, handling and storage
- production and quality controls
- maintenance and repair

Ongoing contractual Scheme elements†:

- regular assessment of production
- formal 3-yearly review

The BBA has awarded this Certificate to the company named above for the product described herein. This product has been assessed by the BBA as being fit for its intended use provided it is installed, used and maintained as set out in this Certificate.

On behalf of the British Board of Agrément

Date of issue: 8 January 2025

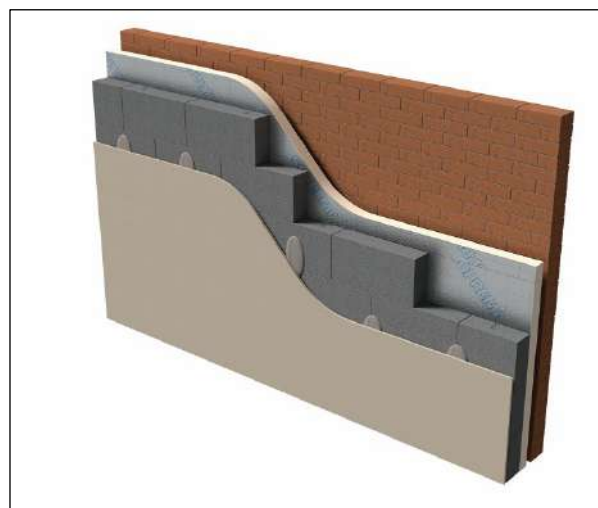

KEY FACTORS ASSESSED

- Section 1. Mechanical resistance and stability
- Section 2. Safety in case of fire
- Section 3. Hygiene, health and the environment
- Section 4. Safety and accessibility in use
- Section 5. Protection against noise
- Section 6. Energy economy and heat retention
- Section 7. Sustainable use of natural resources
- Section 8. Durability

Hardy Giesler
Chief Executive Officer

Certificate amended on 11 December 2025 to update company name, product name and NHBC statement.

This BBA Agrément Certificate is issued under the BBA's Inspection Body accreditation to ISO/IEC 17020. Sections marked with † are not issued under accreditation.

The BBA is a UKAS accredited Inspection Body (No. 4345), Certification Body (No. 0113) and Testing Laboratory (No. 0357).

Readers MUST check that this is the latest issue of this Agrément Certificate by either referring to the BBA website or contacting the BBA directly.

The Certificate should be read in full as it may be misleading to read clauses in isolation.

Any photographs are for illustrative purposes only, do not constitute advice and should not be relied upon.

British Board of Agrément

1st Floor, Building 3, Hatters Lane
Croxley Park, Watford
Herts WD18 8YG

©2025

tel: 01923 665300
clientservices@bbacerts.co.uk
www.bbacerts.co.uk

SUMMARY OF ASSESSMENT AND COMPLIANCE

This section provides a summary of the assessment conclusions; readers should refer to the later sections of this Certificate for information about the assessments carried out.

Compliance with Regulations

Having assessed the key factors, the opinion of the BBA is that SOPRATHERM CW4000 PIR Insulation For Partial Fill Cavity Walls, if installed, used and maintained in accordance with this Certificate, can satisfy or contribute to satisfying the relevant requirements of the following Building Regulations:



The Building Regulations 2010 (England and Wales) (as amended)

Requirement: B3(4)	Internal fire spread (structure)
Comment:	The product can contribute to satisfying this Requirement. See section 2 of this Certificate.
Requirement: B4(1)	External fire spread
Comment:	The product is restricted by this Requirement in some cases. See section 2 of this Certificate.
Requirement: C2(a)	Resistance to moisture
Comment:	The product can contribute to satisfying this Requirement. See section 3 of this Certificate.
Requirement: C2(b)	Resistance to moisture
Comment:	The product can contribute to satisfying this Requirement. See section 9 of this Certificate.
Requirement: C2(c)	Resistance to moisture
Comment:	The product can contribute to satisfying this Requirement. See section 3 of this Certificate.
Requirement: L1(a)(i)	Conservation of fuel and power
Comment:	The product can contribute to satisfying this Requirement; however, compensating fabric measures may be required. See section 6 of this Certificate.
Regulation: 7(1)	Materials and workmanship
Comment:	The product is acceptable. See sections 8 and 9 of this Certificate.
Regulation: 7(2)	Materials and workmanship
Comment:	The product is restricted by this Regulation. See section 2 of this Certificate.
Regulation: 25B	Nearly zero-energy requirements for new buildings
Regulation: 26	CO₂ emission rates for new buildings
Regulation: 26A	Fabric energy efficiency rates for new dwellings (applicable to England only)
Regulation: 26A	Primary energy rates for new buildings (applicable to Wales only)
Regulation: 26B	Fabric performance values for new dwellings (applicable to Wales only)
Regulation: 26C	Target primary energy rates for new buildings (applicable to England only)
Regulation: 26C	Energy efficiency rating (applicable to Wales only)
Comment:	The product can contribute to satisfying these Regulations; however, compensating fabric/service measures may be required. See section 6 of this Certificate.



The Building (Scotland) Regulations 2004 (as amended)

Regulation: 8(1)	Fitness and durability of materials and workmanship
Comment:	The product is acceptable. See sections 8 and 9 of this Certificate.

Regulation:	9	Building standards – construction
Standard:	2.4	Cavities
Comment:		The product can contribute to satisfying this Standard, with reference to clauses 2.4.2 ⁽¹⁾⁽²⁾ , 2.4.4 ⁽¹⁾ and 2.4.6 ⁽²⁾ . See section 2 of this Certificate.
Standard:	2.6	Spread to neighbouring buildings
Comment:		The product is restricted by this Standard in some cases, with reference to clauses 2.6.5 ⁽¹⁾ and 2.6.6 ⁽²⁾ . See section 2 of this Certificate.
Standard:	3.4	Moisture from the ground
Comment:		The product can contribute to satisfying this Standard, with reference to clauses 3.4.1 ⁽¹⁾⁽²⁾ and 3.4.5 ⁽¹⁾⁽²⁾ . See section 3 of this Certificate.
Standard:	3.10	Precipitation
Comment:		The product can contribute to satisfying this Standard, with reference to clauses 3.10.1 ⁽¹⁾⁽²⁾ and 3.10.3 ⁽¹⁾⁽²⁾ . See section 9 of this Certificate.
Standard:	3.15	Condensation
Comment:		The product can contribute to satisfying this Standard, with reference to clauses 3.15.1 ⁽¹⁾⁽²⁾ , 3.15.4 ⁽¹⁾⁽²⁾ and 3.15.5 ⁽¹⁾⁽²⁾ . See section 3 of this Certificate.
Standard:	6.1(b)(c)	Energy demand
Comment:		The product can contribute to satisfying this Standard, with reference to clauses 6.1.1 ⁽¹⁾ and 6.1.2 ⁽²⁾ ; however, compensating fabric/service measures may be required. See section 6 of this Certificate.
Standard:	6.2	Building insulation envelope
Comment:		The product can contribute to satisfying this Standard, with reference to clauses 6.2.1 ⁽¹⁾⁽²⁾ , 6.2.3 ⁽¹⁾ , 6.2.4 ⁽²⁾ , 6.2.8 ⁽¹⁾ , 6.2.9 ⁽²⁾ , and 6.2.12 ⁽¹⁾ ; however, compensating fabric/service measures may be required. See section 6 of this Certificate.
Standard:	7.1(a)(b)	Statement of sustainability
Comment:		The product can contribute to satisfying the relevant requirements of Regulation 9, Standards 1 to 6, and therefore will contribute to a construction meeting at least a bronze level of sustainability as defined in this Standard. In addition, the product can contribute to a construction meeting a higher level of sustainability as defined in this Standard, with reference to clauses 7.1.4 ⁽¹⁾ , 7.1.6 ⁽¹⁾ , 7.1.7 ⁽¹⁾ , 7.1.9 ⁽²⁾ and 7.1.10 ⁽²⁾ . See section 6 of this Certificate.
Regulation:	12	Building standards – conversion
Comment:		All comments given for the product under Regulation 9, Standards 1 to 6, also apply to this Regulation, with reference to clause 0.12.1 ⁽¹⁾⁽²⁾ and Schedule 6 ⁽¹⁾⁽²⁾ .
		(1) Technical Handbook (Domestic). (2) Technical Handbook (Non-Domestic).



The Building Regulations (Northern Ireland) 2012 (as amended)

Regulation:	23(1)(a)(i)	Fitness of materials and workmanship
Comment:	(iii)(b)(i)(ii)	The product is acceptable. See sections 8 and 9 of this Certificate.
Regulation:	23(2)	Fitness of materials and workmanship
Comment:		The product is restricted by this Regulation. See section 2 of this Certificate.
Regulation:	28(a)	Resistance to moisture and weather
Comment:		The product can contribute to satisfying this Regulation. See section 3 of this Certificate.

Regulation:	28(b)	Resistance to moisture and weather
Comment:		The product can contribute to satisfying this Regulation. See section 9 of this Certificate.
Regulation:	29	Condensation
Comment:		The product can contribute to satisfying this Regulation. See section 3 of this Certificate.
Regulation:	35(4)	Internal fire spread – structure
Comment:		The product can contribute to satisfying this Regulation. See section 2 of this Certificate.
Regulation:	36(a)	External fire spread
Comment:		The product is restricted by this Regulation in some cases. See section 2 of this Certificate.
Regulation:	39(a)(i)	Conservation measures
Comment:		The product can contribute to satisfying this Regulation; however, compensating fabric measures may be required. See section 6 of this Certificate.
Regulation:	40(2)	Target carbon dioxide emission rate
Regulation:	43B	Nearly zero-energy requirements for new buildings
Comment:		The product can contribute to satisfying these Regulations; however, compensating fabric/service measures may be required. See section 6 of this Certificate.

Additional Information

NHBC Standards 2025

In the opinion of the BBA, SOPRATHERM CW4000 PIR Insulation For Partial Fill Cavity Walls, if installed, used and maintained in accordance with this Certificate, can satisfy or contribute to satisfying the relevant requirements in relation to *NHBC Standards*, Chapter 6.1 *External masonry walls*.

The opinion of the BBA does not amount to any endorsement or approval by NHBC and does not in any way guarantee that NHBC will approve such product / system as compliant with the NHBC Technical Requirements and Standards.

Fulfilment of Requirements

The BBA has judged SOPRATHERM CW4000 PIR Insulation For Partial Fill Cavity Walls to be satisfactory for use as described in this Certificate. The product has been assessed as partial fill insulation (with a minimum 50 mm residual cavity) in new external cavity walls with masonry inner and outer leaves, in domestic and non-domestic buildings; additional requirements apply for buildings above 12 m in height and further restrictions may apply based on the reaction to fire performance.

ASSESSMENT

Product description and intended use

The Certificate holder provided the following description for the product under assessment. SOPRATHERM CW4000 PIR Insulation For Partial Fill Cavity Walls consists of a rigid PIR foam board with low emissivity composite foil facings on both sides.

The product has the nominal characteristics given in Table 1.

Table 1 Nominal characteristics

Characteristic (unit)	Value
Length (mm)	1200
Width (mm)	450
Thickness (mm)	25 to 100
Edge profile	Square edge or tongue-and-groove
Facings	Composite foil-facing on both sides (printed on one side only)

Ancillary Items

The Certificate holder recommends cavity wall ties with insulation-retaining fixings to BS EN 845-1 : 2013 for use with the product, but these materials have not been assessed by the BBA and are outside the scope of this Certificate.

Applications

The product is intended for use as partial fill cavity wall insulation in external cavity walls with masonry inner and outer leaves (where masonry includes clay and calcium silicate bricks, concrete blocks, and natural and reconstituted stone blocks).

Product assessment – key factors

The product was assessed for the following key factors, and the outcome of the assessment is shown below. Conclusions relating to the Building Regulations apply to the whole of the UK unless otherwise stated.

1 Mechanical resistance and stability

Not applicable.

2 Safety in case of fire

Data were assessed for the following characteristic.

2.1 Reaction to fire

2.1.1 The product was tested for reaction to fire and the classification is given in Table 2.

Table 2 Reaction to fire classification⁽¹⁾

Product assessed	Assessment method	Requirement	Result
SOPRATHERM CW4000 PIR Insulation For Partial Fill Cavity Walls	BS EN 13501-1 : 2018	Value achieved	F

(1) System Laboratories UK Ltd. Report no: 827-A. 18 June 2024. Copies can be obtained from the Certificate holder.

2.1.2 On the basis of data assessed, the product will be restricted in use under the documents supporting the national Building Regulations, in some cases.

2.1.3 In England, Wales and Northern Ireland, the product must not be used on buildings with a storey 18 m or more above ground level and which contain: one or more dwellings, an institution, a room for residential purposes (excluding any room in a hostel, hotel or boarding house in Wales and Northern Ireland only), student accommodation, care homes, sheltered housing or dormitories in boarding schools and, additionally in Northern Ireland, nursing homes and places of lawful detention.

2.1.4 In England, Wales and Northern Ireland, the product is unrestricted in terms of proximity to a relevant boundary and, for constructions comprising two leaves of brick or concrete each at least 75 mm thick and with cavities closed around openings and at the top of the wall (with cavity barriers in Northern Ireland), is also unrestricted in terms of height, except for those constructions described in section 2.1.3.

2.1.5 In England, Wales and Northern Ireland, for constructions other than those described in section 2.1.4, the product must not be used on buildings with a storey 18 m or more above ground level and, in England only, on residential buildings with a storey 11 m or more in height.

2.1.6 In Scotland, the product must not be used on buildings that have a storey 11 m or more above ground level and which contain: a dwelling, a building used as a place of assembly, or as a place of entertainment or recreation, a hospital, a residential care building or sheltered housing complex or a shared multi-occupancy residential building.

2.1.7 In Scotland, the product may be used without restriction on height or proximity to a relevant boundary, other than the buildings described in Section 2.1.6, provided it is installed in a cavity that is between two leaves of masonry or concrete at least 75 mm thick, and which has a cavity barrier around all openings in the wall and at the top of the wall head. For other constructions, the product must not be used on buildings with a storey 11 m or more above ground level or within 1 m of a relevant boundary.

2.1.8 Designers must refer to the relevant national Building Regulations and guidance for detailed conditions of use, particularly in respect of requirements for substrate fire performance, cavity closers and barriers, fire stopping of service penetrations and combustibility limitations for other materials and components used in the overall wall construction.

3 Hygiene, health and the environment

Data were assessed for the following characteristics.

3.1 Effectiveness against rising damp

3.1.1 The product was tested for short-term water absorption by partial immersion and the result is given in Table 3.

Table 3 Short-term water absorption by partial immersion

Product assessed	Assessment method	Requirement	Result
SOPRATHERM CW4000 PIR Insulation For Partial Fill Cavity Walls	BS EN ISO 29767 : 2019	$\leq 1.25 \text{ kg}\cdot\text{m}^{-2}$	Pass

3.1.2 On the basis of data assessed, the product may be used in situations where it bridges the damp-proof course (DPC) in walls; dampness from the ground will not pass through to the inner leaf provided the wall is detailed in accordance with the requirements and provisions of the national Building Regulations.

3.2 Water vapour permeability

3.2.1 The product components were assessed for water vapour resistivity/resistance and the results are given in Table 4.

Table 4 Water vapour resistivity/resistance

Material	Assessment method	Requirement	Result
PIR insulation	BS EN ISO 10456 : 2007	Declared value	$300 \text{ MN}\cdot\text{s}\cdot\text{g}^{-1}\cdot\text{m}^{-1}$
Composite foil facer	BS 5250 : 2021		$1000 \text{ MN}\cdot\text{s}\cdot\text{g}^{-1}$

3.2.2 For the purposes of assessing the risk of condensation, the water vapour resistivity/resistance values of each component may be taken as given in Table 4.

4 Safety and accessibility in use

Not applicable.

5 Protection against noise

Not applicable.

6 Energy economy and heat retention

Data were assessed for the following characteristics.

6.1 Thermal conductivity

The product was tested for thermal conductivity and the result is given in Table 5.

Table 5 Thermal conductivity

Product assessed	Assessment method	Requirement	Result
SOPRATHERM CW4000 PIR Insulation For Partial Fill Cavity Walls	BS EN 13165 : 2012	Declared value (λ_D)	0.022 W·m ⁻¹ ·K ⁻¹

6.2 Thermal performance

The foil facing was tested for emissivity and the result is given in Table 6.

Table 6 Emissivity of the foil facing

Product assessed	Assessment method	Requirement	Result
Foil facing	BS EN 15976 : 2011	Declared value	0.05

6.3 Conservation of fuel and power

6.3.1 The U value of a completed wall construction will depend on the insulation thickness, the number and type of fixings, the wall structure and its internal finish. Example U values are given in Table 7.

Table 7 Example U values⁽¹⁾ — partial fill insulation (50 mm residual cavity)

Target U value (W·m ⁻² ·K ⁻¹)	Insulation thickness (mm)	
	100 mm dense block with 13 mm dense plaster ⁽²⁾	100 mm AAC block Plasterboard on dabs ⁽³⁾
0.13	— ⁽⁴⁾	— ⁽⁴⁾
0.15	— ⁽⁴⁾	— ⁽⁴⁾
0.17	— ⁽⁴⁾	90
0.18	100	80
0.21	80	65
0.26	60	45
0.28	55	40
0.30	50	35

(1) The U value calculations are based on the following:

- wall ties: stainless steel ($\lambda = 17 \text{ W}\cdot\text{m}^{-1}\cdot\text{K}^{-1}$), 2.5 per m², 12.5 mm² cross-section
 - 102.5 mm brick ($\lambda = 0.77 \text{ W}\cdot\text{m}^{-1}\cdot\text{K}^{-1}$) bridged by mortar (6.7%, $\lambda = 0.88 \text{ W}\cdot\text{m}^{-1}\cdot\text{K}^{-1}$)
 - 50 mm low e cavity ($\epsilon = 0.05$).
- (2) 100 mm dense block ($\lambda = 1.13 \text{ W}\cdot\text{m}^{-1}\cdot\text{K}^{-1}$) bridged by mortar (6.7%, $\lambda = 0.88 \text{ W}\cdot\text{m}^{-1}\cdot\text{K}^{-1}$), and 13 mm dense plaster ($\lambda = 0.57 \text{ W}\cdot\text{m}^{-1}\cdot\text{K}^{-1}$).
- (3) 100 mm AAC block ($\lambda = 0.12 \text{ W}\cdot\text{m}^{-1}\cdot\text{K}^{-1}$) bridged by mortar (6.7%, $\lambda = 0.88 \text{ W}\cdot\text{m}^{-1}\cdot\text{K}^{-1}$), and 12.5 mm plasterboard ($\lambda = 0.21 \text{ W}\cdot\text{m}^{-1}\cdot\text{K}^{-1}$) on 15 mm plaster dabs (20%, $\lambda = 0.43 \text{ W}\cdot\text{m}^{-1}\cdot\text{K}^{-1}$).
- (4) See section 6.3.3.

6.3.2 On the basis of data assessed, the product can contribute towards a construction satisfying the national Building Regulations in respect of energy economy and heat retention.

6.3.3 For improved energy or carbon savings, designers must consider appropriate fabric/service measures.

7 Sustainable use of natural resources

Not applicable.

8 Durability

8.1 The potential mechanisms for degradation and the known performance characteristics of the materials in the product were assessed.

8.2 Specific test data were assessed as given in Table 8.

Table 8 Durability

Product assessed	Assessment method	Requirement	Declared level
SOPRATHERM CW4000 PIR Insulation For Partial Fill Cavity Walls	Dimensional stability to BS EN 1604 : 1996 (70°C and 90-100% RH for 48 hours)	Length and width \leq 2 % change Thickness \leq 6 % change	Pass
	Dimensional stability to BS EN 1604 : 1996 (-20°C for 48 hours)	Length and width \leq 1 % change Thickness \leq 2 % change	Pass

8.3 Service life

Under normal service conditions, the product will have a life equivalent to the structure in which it is incorporated, provided it is designed, installed and maintained in accordance with this Certificate and the Certificate holder's instructions.

PROCESS ASSESSMENT

Information provided by the Certificate holder was assessed for the following factors:

9 Design, installation, workmanship and maintenance

9.1 Design

9.1.1 The design process was assessed, and the following requirements apply in order to satisfy the performance assessed in this Certificate.

9.1.2 External masonry cavity walls must be designed and constructed in accordance with the relevant recommendations of :

- BS 5250 : 2021
- BS 8000-3 : 2020
- BS EN 845-1 : 2013
- BS EN 1996-1-1 : 2005 and its UK National Annex
- BS EN 1996-1-2 : 2005 and its UK National Annex
- BS EN 1996-2 : 2006 and its UK National Annex
- BS EN 1996-3 : 2006 and its UK National Annex.

9.1.3 As with other forms of cavity wall insulation, where buildings need to comply with the *NHBC Standards*, specifiers must observe the requirements of that document.

9.1.4 Cavity wall ties with insulation-retaining fixings and, if required, any additional ties to BS EN 845-1 : 2013 must be used for structural stability in accordance with BS EN 1996-1-1 : 2005, BS EN 1996-2 : 2006 and BS EN 1996-3 : 2006, and their UK National Annexes.

9.1.5 Care must be taken in the overall design and construction of walls incorporating the product to ensure the provision of appropriate:

- cavity trays and DPCs
- cavity barriers
- resistance to the ingress of precipitation, moisture and dangerous gases from the ground
- resistance to sound transmission when flanking separating walls and floors.

9.1.6 Provided that external masonry cavity walls are designed and constructed to incorporate the precautions in this Certificate to prevent moisture penetration, the product will resist the transfer of precipitation to the inner leaf.

9.1.7 Window and door opening reveals must be constructed incorporating a cavity barrier/closer/DPC, as required.

9.1.8 The detailed provisions given in the documents supporting the national Building Regulations for when the product is installed in close proximity to certain flue pipes and/or heat-producing appliances must be followed.

9.1.9 Calculations of the thermal transmittance (U value) of a wall must be carried out in accordance with BS EN ISO 6946 : 2017 and BRE Report BR 443 : 2019.

9.1.10 Care must be taken in the overall design and construction of junctions with other elements and openings to minimise thermal bridges and air infiltration. Detailed guidance can be found in the documents supporting the national Building Regulations.

Interstitial condensation

9.1.11 Walls will adequately limit the risk of interstitial condensation when they are designed and constructed in accordance with BS 5250 : 2021.

9.1.12 If the product is to be used in the external wall of rooms expected to have high humidity, care must be taken to provide adequate permanent ventilation to avoid possible problems from the formation of interstitial condensation.

Surface condensation

9.1.13 In England and Wales, walls will adequately limit the risk of surface condensation when the thermal transmittance (U value) does not exceed $0.7 \text{ W}\cdot\text{m}^{-2}\cdot\text{K}^{-1}$ at any point, and the junctions with other elements are designed in accordance with the guidance referred to in section 9.1.10 of this Certificate.

9.1.14 For buildings in Scotland, wall constructions will be acceptable when the thermal transmittance (U value) does not exceed $1.2 \text{ W}\cdot\text{m}^{-2}\cdot\text{K}^{-1}$ at any point, and the junctions with other elements are designed in accordance with the guidance referred to in BS 5250 : 2021. Further guidance may be obtained from BRE Report BR 262 : 2002 and section 9.1.10 of this Certificate.

Buildings up to and including 25 m high (see also section 2 of this Certificate)

9.1.15 The residual cavity width to be maintained during construction is 50 mm. This may reduce to 25 mm in isolated areas due to individual construction features (a minimum of 50 mm residual cavity width is required by the NHBC). This may be achieved by designing a cavity width which takes into account the dimensional tolerances of the components which make up the wall (by reference to the British Standards relating to the bricks, blocks and boards, or by using the data from the respective manufacturers). Allowances may need to be made for the quality of building operatives and the degree of site supervision or control available. The limitations in respect of exposure of the proposed building as set out in Table 9 must also be observed.

Table 9 Maximum allowable exposure index $E^{(1)}$

Construction	Maximum allowable exposure index $E^{(1)}$
All external masonry walls protected by: rendering (to BS EN 13914-1 : 2016), tile hanging, slate hanging, or timber, plastic or metal weatherboarding or cladding	No restriction
One or more external masonry walls constructed from facing clay brickwork or natural stone, the porosity of which exceeds 20% by volume. Mortar joints must be flush pointed or weatherstruck	100
One or more external masonry walls constructed from calcium silicate bricks, concrete blocks, reconstituted stone, or natural stone, the porosity of which is less than 20% by volume, or any material with raked mortar joints	88

(1) To BS 5618 : 1985.

9.1.16 From ground level, the maximum height of continuous cavity walls must not exceed 12 m; above 12 m the maximum height of continuous cavity walls must not exceed 7 m. In both cases, breaks must be in the form of continuous horizontal cavity trays and weepholes discharging to the outside.

9.1.17 An external render coat or other suitable finish should be applied in locations where such application would be normal practice; care must be taken to ensure that the residual cavity is not bridged by mortar.

Buildings over 25 m in height (see also section 2 of this Certificate)

9.1.18 The width of the residual clear cavity to be achieved must be in excess of 50 mm, and the following additional requirements apply in addition to those stated in sections 9.1.15 to 9.1.17:

- the specifier must take extra care when detailing to ensure that the introduction of the insulation does not affect the weather resistance of the wall. Above average site supervision is recommended during installation of the product
- where, for structural reasons, the cavity width is reduced, eg by the intrusion of ring beams, a minimum residual cavity width of 25 mm must be maintained and extra care must be taken with fixings and weatherproofing, eg the inclusion of cavity trays with weepholes.

9.2 Installation

9.2.1 Installation instructions provided by the Certificate holder were assessed and judged to be appropriate and adequate.

9.2.2 Installation must be carried out in accordance with this Certificate and the Certificate holder's instructions. A summary of instructions and guidance is provided in Annex A of this Certificate.

9.2.3 The inner leaf must be constructed ahead of the outer leaf, as the boards are fastened to the cavity face of the inner leaf. It is essential that the spacing of wall ties/clips allows one long edge of each board to be secured at a minimum of two points.

9.2.4 Vertical joints in the boards must be staggered and all joints tightly butted. Where protrusions occur in the cavity, the boards must be carefully cut to fit.

9.2.5 If installation of the boards is terminated below the highest level of the wall, the top edge of the insulation must be protected by a cavity tray and alternate perpend joints raked out to provide adequate drainage of water from the tray.

9.2.6 In all situations, it is particularly important to ensure during installation that:

- installation is carried out to the highest level on each wall or the top edge of the insulation is protected by a cavity tray
- cavity trays are used with appropriate stop ends and weepholes at lintel level
- cavity battens and/or boards are used during construction to prevent bridging by mortar droppings
- wall ties are installed correctly and are thoroughly clean

- excess mortar is cleaned from the cavity face of the leading leaf and any debris removed from the cavity
- mortar droppings are cleaned from the exposed edges of installed boards
- insulation boards are properly installed and either butt jointed, or interlocked using the tongue and groove or rebated edges
- the DPC at ground level does not project into the cavity as it can form a trap for mortar bridging
- raked or recessed mortar joints are avoided in very severe exposure areas.

9.3 Workmanship

Practicability of installation was assessed by the BBA, on the basis of the Certificate holder's information. To achieve the performance described in this Certificate, installation of the product must be carried out by a competent general builder, or a contractor, experienced with this type of product.

9.4 Maintenance and repair

As the product is confined within the wall cavity and has suitable durability, maintenance is not required.

10 Manufacture

10.1 The production processes for the product have been assessed, and provide assurance that the quality controls are satisfactory according to the following factors:

10.1.1 The manufacturer has provided documented information on the materials, processes, testing and control factors.

10.1.2 The quality control operated over batches of incoming materials has been assessed and deemed appropriate and adequate.

10.1.3 The quality control procedures and product testing to be undertaken have been assessed and deemed appropriate and adequate.

10.1.4 The process for management of non-conformities has been assessed and deemed appropriate and adequate.

10.1.5 An audit of each production location was undertaken, and it was confirmed that the production process was in accordance with the documented process, and that equipment has been properly tested and calibrated.

† 10.2 The BBA has undertaken to review the above measures on a regular basis through a surveillance process, to verify that the specifications and quality control operated by the manufacturer are being maintained.

11 Delivery and site handling

11.1 The Certificate holder stated that the product is delivered to site in packaging bearing the product name, the Certificate holder's name, the batch number, and the BBA Certificate number.

11.2 Delivery and site handling must be performed in accordance with the Certificate holder's instructions and this Certificate, including:

11.2.1 The product must be protected from prolonged exposure to sunlight, and must be stored under cover or protected with opaque polythene sheeting. Where possible, packs should be stored inside. If stored outside, the product must be stacked flat, and raised above ground level and not in contact with ground moisture.

11.2.2 Care must be taken when handling the boards to avoid crushing the edges or corners.

11.2.3 The product must not be exposed to open flame or other ignition sources, or solvents or other chemicals.

11.2.4 If damaged or wet, the product must be discarded.

Supporting information in this Annex is relevant to the product but has not formed part of the material assessed for the Certificate.

Construction (Design and Management) Regulations 2015

Construction (Design and Management) Regulations (Northern Ireland) 2016

Information in this Certificate may assist the client, designer (including Principal Designer) and contractor (including Principal Contractor) to address their obligations under these Regulations.

UKCA marking

The Certificate holder has taken the responsibility of UKCA marking the product in accordance with Designated Standard BS EN 13165 : 2012.

Management Systems Certification for production

The management system of the manufacturer has been assessed and registered as meeting the requirements of BS EN ISO 9001 : 2015 and BS EN ISO 14001 : 2015 by BSI Assurance UK Ltd (Certificates FM 781023 and EMS 781017 respectively).

Additional information on installation

A.1 The Certificate holder will provide on-site demonstrations on request, to ensure correct installation from the outset.

A.2 Adequate supervision of the installation must be maintained and the Certificate holder must have right of access to site to ensure correct installation.

Procedure

A.3 A section of the inner leaf is built, with the first row of wall ties, at approximately 600 mm horizontal spacing, where the insulation is to begin. The wall ties must not be placed directly on the DPC. The insulation should extend below the DPC and be at least 215 mm below the floor slab and beyond the floor insulation.

A.4 The leading leaf is then built up to the required height, with wall ties placed at a vertical spacing of 450 mm, ensuring the drip of the tie is located halfway across the residual cavity width. Excess mortar must be cleaned from the cavity face of the leading leaf, and the boards placed on the wall ties behind the retaining clips, to form a closely butt-jointed run.

A.5 The second row of wall ties is fitted to retain the tops of the boards. It is essential that all wall ties slope downwards towards the outer leaf and are placed at centres not exceeding 900 mm⁽¹⁾, to ensure that each board is secured at a minimum of three points. It is also important that the first row of insulation boards is not in contact with the ground.

(1) Where buildings need to comply with *NHBC Standards*, the spacing should be no more than 600 mm.

A.6 Additional ties may be required to satisfy the structural requirements of BS EN 845-1 : 2013, BS EN 1996-1-1 : 2005, BS EN 1996-2 : 2006 and BS EN 1996-3 : 2006 to ensure adequate retention of boards or cut pieces.

A.7 The other leaf is built up to the level of the top of the boards.

A.8 All boards should be either close-butted together (for plain edge boards) or interlocked (for tongue-and-groove boards), with vertical joints staggered. Insulation boards and wall ties must be staggered as construction proceeds and carried up to the highest level of the wall, except where protected by a cavity tray. Boards with a tongue-and-groove edge require slots to be cut in the top tongue, to allow for placement of the wall ties (including insulation retainers).

Mortar droppings

A.9 After each section of the leading leaf is built, excess mortar must be removed from the cavity face and mortar droppings cleaned from exposed edges of the installed board, before installation of the next run of boards. Use of a cavity board or a cavity batten will protect the installed board edges and help to keep the cavity clean as the following leaf is built (see Figure 1).

Figure 1 Use of cavity board

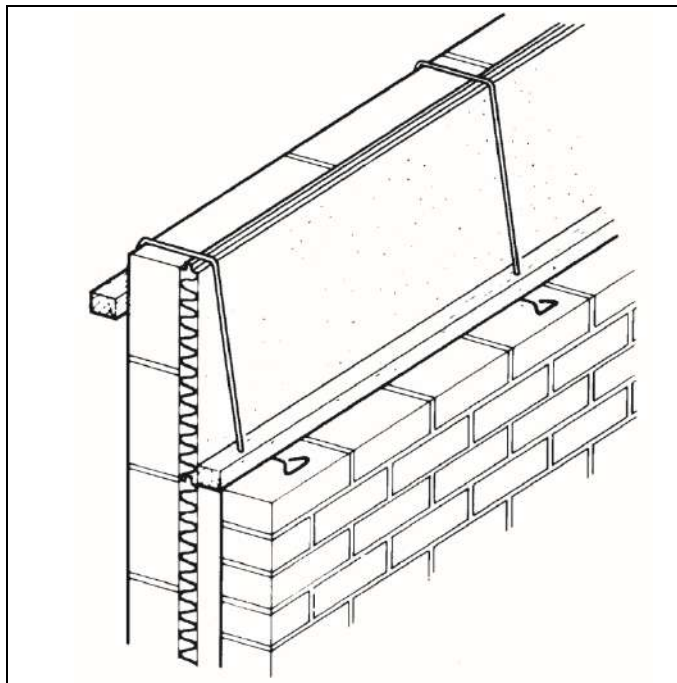

Wall openings

A.10 Where openings such as doors and windows are in close proximity, it is recommended that a continuous lintel or cavity tray is used. Individual lintels or cavity trays should have stopends and be adequately drained. Insulation boards must be cut to butt tightly against the cavity barrier/closer/DPC.

Cut pieces

A.11 The product can be cut using a sharp knife or fine-toothed saw to fit openings, eg around windows, doors and airbricks. It is essential that cut pieces completely fill the spaces for which they are intended and are adequately secured.

Protection

A.12 Exposed areas of boards must always be covered at the end of a day's work or during rainfall.

A.13 All building involving the product, particularly interrupted work, must conform to the relevant sections of BS EN 1996-2 : 2006.

Bibliography

- BRE Report BR 262 : 2002 *Thermal insulation : avoiding risk*
- BRE Report BR 443 : 2019 *Conventions for U-value calculations*
- BS 5250 : 2021 *Management of moisture in buildings — Code of practice*
- BS 5618 : 1985 *Code of practice for thermal insulation of cavity walls (with masonry or concrete inner and outer leaves) by filling with urea-formaldehyde (UF) foam systems*
- BS 8000-3 : 2020 *Workmanship on building sites — Code of practice for masonry*
- BS EN 845-1 : 2013 + A1 : 2016 *Specification for ancillary components for masonry — Wall ties, tension straps, hangers and brackets*
- BS EN 1604 : 1996 *Thermal insulating products for building applications — Determination of dimensional stability under specified temperature and humidity conditions*
- BS EN 1996-1-1 : 2005 + A1 : 2012 *Eurocode 6 — Design of masonry structures — General rules for reinforced and unreinforced masonry structures*
- NA to BS EN 1996-1-1 : 2005 + A1 : 2012 *UK National Annex to Eurocode 6 — Design of masonry structures — General rules*
- BS EN 1996-1-2 : 2005 *Eurocode 6 — Design of masonry structures — General rules for reinforced and unreinforced masonry structures*
- NA to BS EN 1996-1-2 : 2005 *UK National Annex to Eurocode 6 — Design of masonry structures — General rules*
- BS EN 1996-2 : 2006 *Eurocode 6 — Design of masonry structures — Design considerations, selection of materials and execution of masonry*
- NA to BS EN 1996-2 : 2006 *UK National Annex to Eurocode 6 — Design of masonry structures — Design considerations, selection of materials and execution of masonry*
- BS EN 1996-3 : 2006 *Eurocode 6 — Design of masonry structures — Simplified calculation methods for unreinforced masonry structures*
- NA to BS EN 1996-3 : 2006 *UK National Annex to Eurocode 6 — Design of masonry structures — Simplified calculation methods for unreinforced masonry structures*
- BS EN 13165 : 2012 + A2 : 2016 *Thermal insulation products for buildings — Factory made rigid polyurethane foam (PU) products — Specification*
- BS EN 13501-1 : 2018 *Fire classification of construction products and building elements — Classification using test data from reaction to fire tests*
- BS EN 13914-1 : 2016 *Design, preparation and application of external rendering and internal plastering — External rendering*
- BS EN 15976 : 2011 *Flexible sheets for waterproofing — Determination of emissivity*
- BS EN ISO 6946 : 2017 *Building components and building elements — Thermal resistance and thermal transmittance — Calculation method*
- BS EN ISO 9001 : 2015 *Quality management systems — Requirements*
- BS EN ISO 10456 : 2007 *Building materials and products — Hygrothermal properties — Tabulated design values and procedures for determining declared and design thermal values*
- BS EN ISO 14001 : 2015 *Environmental management systems — Requirements with guidance for use*
- BS EN ISO 29767 : 2019 *Thermal insulating products for building applications — Determination of dimensional short term water absorption by partial immersion*

Conditions

1 This Certificate:

- relates only to the product that is named and described on the front page
- is issued only to the company, firm, organisation or person named on the front page – no other company, firm, organisation or person may hold or claim that this Certificate has been issued to them
- has to be read, considered and used as a whole document – it may be misleading and will be incomplete to be selective
- is copyright of the BBA
- and any matter arising out of or in connection with it or its subject matter (including non-contractual disputes or claims) is governed by and construed in accordance with the law of England and Wales.
- the courts of England and Wales shall have exclusive jurisdiction to settle any matter arising out of or in connection with this Certificate or its subject matter (including non-contractual disputes or claims).

2 Publications, documents, specifications, legislation, regulations, standards and the like referenced in this Certificate are those that were current and/or deemed relevant by the BBA at the date of issue or reissue of this Certificate.

3 This Certificate will be displayed on the BBA website, and the Certificate Holder is entitled to use the Certificate and Certificate logo, provided that the product and its manufacture and/or fabrication, including all related and relevant parts and processes thereof:

- are maintained at or above the levels which have been assessed and found to be satisfactory by the BBA
- continue to be checked as and when deemed appropriate by the BBA under arrangements that it will determine
- are reviewed by the BBA as and when it considers appropriate.

4 The BBA has used due skill, care and diligence in preparing this Certificate, but no warranty is provided.

5 In issuing this Certificate the BBA is not responsible and is excluded from any liability to any company, firm, organisation or person, for any matters arising directly or indirectly from:

- the presence or absence of any patent, intellectual property or similar rights subsisting in the product or any other product
- the right of the Certificate holder to manufacture, supply, install, maintain or market the product
- actual installations of the product, including their nature, design, methods, performance, workmanship and maintenance
- any works and constructions in which the product is installed, including their nature, design, methods, performance, workmanship and maintenance
- any loss or damage, including personal injury, howsoever caused by the product, including its manufacture, supply, installation, use, maintenance and removal
- any claims by the manufacturer relating to UKCA marking and CE marking.

6 Any information relating to the manufacture, supply, installation, use, maintenance and removal of this product which is contained or referred to in this Certificate is the minimum required to be met when the product is manufactured, supplied, installed, used, maintained and removed. It does not purport in any way to restate the requirements of the Health and Safety at Work etc. Act 1974, or of any other statutory, common law or other duty which may exist at the date of issue or reissue of this Certificate; nor is conformity with such information to be taken as satisfying the requirements of the 1974 Act or of any statutory, common law or other duty of care.