

# Installation and Maintenance Instructions

## Wall hung rsf gas fired condensing appliance

# Greenstar Ri<sup>ErP+</sup>

For open vented & sealed system central heating systems & indirect mains fed domestic hot water



672084744-00-1W6

| These appliances are for use with:<br>Natural Gas or LPG<br>(Cat. II 2H 3P type C13, C33 & C53) |                      |           |
|---|----------------------|-----------|
|   | Model                | GC Number |
| Natural Gas   | 9Ri <sup>ErP+</sup>  | 41-406-74 |
|   | 12Ri <sup>ErP+</sup> | 41-406-75 |
|   | 15Ri <sup>ErP+</sup> | 41-406-76 |
|   | 18Ri <sup>ErP+</sup> | 41-406-77 |
|   | 21Ri <sup>ErP+</sup> | 41-406-78 |
|   | 24Ri <sup>ErP+</sup> | 41-406-79 |
| LPG   | 9Ri <sup>ErP+</sup>  | 41-406-68 |
|   | 12Ri <sup>ErP+</sup> | 41-406-69 |
|   | 15Ri <sup>ErP+</sup> | 41-406-70 |
|   | 18Ri <sup>ErP+</sup> | 41-406-71 |
|   | 21Ri <sup>ErP+</sup> | 41-406-72 |
|   | 24Ri <sup>ErP+</sup> | 41-406-73 |

If you smell gas:

- ▶ Keep well away from the building: call the National Gas Emergency Service on 0800 111 999.
- ▶ LPG appliances: Call the supplier's number on the side of the gas tank.



## CONTENTS

|          |  |           |          |   |           |
|----------|--|-----------|----------|---|-----------|
| <b>1</b> | <b>KEY TO SYMBOLS AND SAFETY PRECAUTIONS</b> .....               | <b>4</b>  | <b>5</b> | <b>INSTALLATION</b> .....   | <b>31</b> |
| 1.1      | Key to symbols .....   | 4         | 5.1      | Unpacking the wall frame & ancillary items .....                  | 31        |
| 1.2      | Safety precautions .....   | 5         | 5.2      | Position the appliance .....                                      | 32        |
| <b>2</b> | <b>Regulations</b> .....   | <b>6</b>  | 5.3      | Wall mounting template & flue opening .....                       | 32        |
| <b>3</b> | <b>APPLIANCE INFORMATION</b> .....                               | <b>7</b>  | 5.4      | Outer case removal .....  | 33        |
| 3.1      | Appliance .....  | 7         | 5.5      | appliance connection .....  | 33        |
| 3.2      | Technical data .....   | 8         | 5.5.1    | Condensate connection .....                                       | 34        |
| 3.3      | Energy efficiency .....  | 10        | 5.6      | Flue turret/adaptor installation .....                            | 35        |
| 3.4      | appliance main components .....                                  | 12        | 5.7      | Electrical connections .....                                      | 36        |
| 3.5      | Internal wiring diagram .....                                    | 13        | <b>6</b> | <b>COMMISSIONING</b> .....  | <b>37</b> |
| <b>4</b> | <b>PRE-INSTALLATION</b> .....                                    | <b>14</b> | 6.1      | Pre-Commissioning checks .....                                    | 37        |
| 4.1      | Mains supply .....   | 14        | 6.2      | Filling the system .....  | 38        |
| 4.1.1    | Electrical supply .....  | 14        | 6.3      | Water treatment .....   | 38        |
| 4.1.2    | Gas supply .....   | 14        | 6.4      | Starting the appliance .....                                      | 39        |
| 4.2      | Water systems and pipe work .....                                | 14        | 6.4.1    | Appliance controls .....  | 39        |
| 4.3      | Condensate discharge .....                                       | 16        | 6.5      | Commissioning .....   | 39        |
| 4.3.1    | Condensate pipe work .....                                       | 16        | 6.5.1    | Checking the gas inlet pressure .....                             | 39        |
| 4.3.2    | Internal connections .....                                       | 17        | 6.5.2    | Checking the gas rate .....                                       | 40        |
| 4.3.3    | External connection considerations .....                         | 18        | 6.6      | CO and Combustion checks .....                                    | 40        |
| 4.4      | Pressure relief pipe work .....                                  | 19        | 6.7      | Finishing commissioning .....                                     | 42        |
| 4.4.1    | Alternative PRV connections - Combined<br>PRV/condensate .....   | 19        | 6.7.1    | Replace the outer case: .....                                     | 42        |
| 4.5      | appliance location and clearances .....                          | 20        | 6.7.2    | Install the bottom panel .....                                    | 42        |
| 4.5.1    | Installation .....   | 20        | 6.7.3    | Hand over .....   | 42        |
| 4.5.2    | Servicing clearances -<br>Ventilated compartment .....           | 20        | 6.7.4    | Appliance guarantee .....   | 43        |
| 4.5.3    | Compartments: .....  | 20        | <b>7</b> | <b>SERVICE AND SPARES</b> .....                                   | <b>43</b> |
| 4.5.4    | appliance clearances- Unventilated<br>compartments .....         | 20        | 7.1      | Inspection and service .....                                      | 43        |
| 4.5.5    | Installation clearances - unventilated<br>compartments .....     | 20        | 7.2      | Checking gas inlet pressure .....                                 | 44        |
| 4.5.6    | Rooms containing a bath or shower .....                          | 21        | 7.3      | Checking flue integrity .....                                     | 45        |
| 4.6      | Plumbing manifold .....  | 22        | 7.4      | Fan pressure test .....   | 45        |
| 4.6.1    | Connections .....  | 22        | 7.5      | Flue gas analysis .....   | 46        |
| 4.7      | Flue options .....   | 23        | 7.6      | Setting the air/gas ratio .....                                   | 47        |
| 4.7.1    | Flue lengths .....   | 23        | 7.6.1    | Setting the CO/CO2 .....  | 47        |
| 4.8      | Flue terminal positions .....                                    | 25        | 7.7      | Cleaning the heat exchanger .....                                 | 47        |
| 4.8.1    | Vertical flue terminal positions .....                           | 25        | 7.7.1    | Syphon removal and cleaning .....                                 | 49        |
| 4.8.2    | Horizontal flue terminal positions .....                         | 26        | 7.8      | Replacement of parts .....  | 50        |
| 4.8.3    | Plume re-direct and plume management terminal<br>positions ..... | 28        | 7.8.1    | Removing the outer casing .....                                   | 50        |
| 4.9      | Cleaning primary systems .....                                   | 30        | 7.8.2    | Primary sensor (CHNTC) .....                                      | 50        |
| 4.9.1    | Flushing the system .....  | 30        | 7.8.3    | Overheat thermostat .....   | 51        |
|          |  |           | 7.8.4    | Flue overheat thermostat<br>(with grommet) .....                  | 51        |
|          |  |           | 7.8.5    | Lowering the appliance controls to the service<br>position: ..... | 52        |
|          |  |           | 7.8.6    | Gas valve .....   | 52        |
|          |  |           | 7.8.7    | Air/gas manifold and fan assembly .....                           | 52        |
|          |  |           | 7.8.8    | Air pressure switch .....   | 53        |
|          |  |           | 7.8.9    | Fan .....   | 53        |
|          |  |           | 7.8.10   | Electrode assembly and burner .....                               | 54        |
|          |  |           | 7.8.11   | Re-assembly of the burner clamping plate .....                    | 54        |
|          |  |           | 7.8.12   | Heat exchanger .....  | 55        |
|          |  |           | 7.8.13   | Syphon removal .....  | 56        |
|          |  |           | 7.8.14   | Access to electrical control panel .....                          | 57        |
|          |  |           | 7.8.15   | PCB Fuse and code plug .....                                      | 57        |
|          |  |           | 7.8.16   | PCB .....   | 57        |

---

|          |                                    |           |
|----------|------------------------------------|-----------|
| <b>8</b> | <b>FAULT FINDING AND DIAGNOSIS</b> | <b>58</b> |
| 8.1      | Fault finding                      | 59        |

---

|          |   |           |
|----------|---|-----------|
| <b>9</b> | <b>OPERATIONAL FUNCTIONS</b>              | <b>60</b> |
| 9.1      | Appliance function                        | 60        |
| 9.2      | Protection function                       | 61        |
| 9.3      | Component Characteristics                 | 62        |
| 9.3.1    | Flow temperature (NTC) Sensor resistances | 62        |
| 9.3.2    | Flue overheat thermostat                  | 62        |
| 9.3.3    | Overheat thermostat                       | 62        |
| 9.3.4    | Gas valve coil resistances                | 62        |
| 9.3.5    | Code plug numbers                         | 62        |

## 1 KEY TO SYMBOLS AND SAFETY PRECAUTIONS

### 1.1 KEY TO SYMBOLS

#### WARNINGS

|   |   |
|---|---|
|  | <p>Warnings in this document are identified by a warning triangle printed against a grey background.</p> <p>Keywords at the start of a warning indicate the type and seriousness of the ensuing risk if measures to prevent the risk are not taken.</p> |
|---|---|

The following keywords are defined and can be used in this document:

- **NOTICE** indicates a situation that could result in damage to property or equipment.
- **CAUTION** indicates a situation that could result in minor to medium injury.
- **WARNING** indicates a situation that could result in severe injury or death.
- **DANGER** indicates a situation that will result in severe injury or death.

#### IMPORTANT INFORMATION

|   |  |
|---|--|
|  | <p>This symbol indicates important information where there is no risk to people or property.</p> |
|---|--|

#### ADDITIONAL SYMBOLS

| Symbol | Meaning   |
|--------|---|
| 1.     | a numbered step in an action sequence                                       |
| ▶      | a step in an action sequence  |
| →      | a reference to a related part in the document or to other related documents |
| ①      | a reference number to identify or refer to a part or item                   |
| .      | a list entry  |
| -      | a list entry (second level)   |

Table 1 Symbols

#### Examples of additional symbols used

##### A numbered step in an action sequence

A sequence of numbered steps or actions carried out in a specific order to complete a task.

1. First action
2. Second action
3. Third action
- etc.

##### A step in an action sequence

A sequence of defined actions or steps carried out in order to complete a task.

- ▶ Action
- ▶ Next action
- ▶ etc

##### A reference to a related part in the document or to other related documents.

To refer the reader to a specific figure/table/section within the manual.

→ e.g. figure 1.

##### A reference number to identify or refer to a part or item.

In a related figure, items or parts identified by a sequential number.

#### List entries, first and second levels

- A single component/item
- A component/list, made up of multiple parts/items.
  - Sub component or sublist of main component/list.
  - etc.

#### SYMBOLS USED IN THIS MANUAL





|   |                            |
|---|----------------------------|
|  | Domestic Hot Water         |
|  | Central Heating            |
|  | Hot Water Storage Cylinder |
|  | Domestic Cold Water Supply |
|  | Gas Supply                 |

Table 2 Commonly used symbols

#### PLEASE READ THESE INSTRUCTIONS CAREFULLY BEFORE STARTING INSTALLATION.

|  |
|--|
| <p>These instructions are applicable to the Worcester appliance model(s) stated on the front cover of this manual only and must not be used with any other make or model of appliance.</p>   |
| <p>These instructions apply in the UK and Ireland only and must be followed except for any statutory obligations.</p>  |
| <p>This appliance must be installed and serviced by a <b>GAS SAFE</b> registered, competent person. Failure to install correctly could lead to prosecution.</p>  |
| <p>If you are in any doubt, contact the Worcester Technical helpline (0330 123 3366).</p>  |
| <p>Please leave these instructions with the completed BENCHMARK CHECKLIST, (or a certificate confirming compliance with IS 813, Eire only) and the user manual with the owner or at the gas meter after installation or servicing.</p> |
| <p>Distance learning and training courses are available from Worcester.</p>  |
| <p>The BENCHMARK CHECKLIST can be found in the back of this Installation manual.</p>   |

|        |   |
|--------|---|
| ∅      | Diameter  |
| NG     | Natural Gas   |
| LPG    | Liquid Petroleum Gas  |
| CH     | Central Heating   |
| DHW    | Domestic Hot Water  |
| DCW    | Domestic Cold Water   |
| DWTA   | Domestic Water Treatment Association                          |
| PRV    | Pressure Relief Valve   |
| NTC    | Negative Temperature Coefficient (sensor)                     |
| IP     | Ingress Protection  |
| RCD    | Residual Current Device                                       |
| TRV    | Thermostatic Radiator Valve                                   |
| ECV    | Emergency Control Valve                                       |
| WRAS   | Water Regulations Advisory Scheme                             |
| SEDBUK | Seasonal Efficiency of Domestic Boilers in the United Kingdom |

Table 3 Abbreviations use in this manual

## 1.2 SAFETY PRECAUTIONS

### IF YOU SMELL GAS

A gas leak could potentially cause an explosion. If you smell gas, observe the following rules.

- ▶ Prevent flames or sparks:
  - Do not smoke, use a lighter or strike matches.
  - Do not operate any electrical switches or unplug any equipment.
  - Do not use the telephone or ring doorbells.
- ▶ Turn off the gas at the meter or regulator.
- ▶ Open windows and doors.
- ▶ Warn your neighbours and leave the building.
- ▶ Prevent anyone from entering the building.
- ▶ Well away from the building: call the National Gas Emergency Service on 0800 111 999.
- ▶ LPG appliances: Call the supplier's number on the side of the gas tank.



Benchmark places responsibilities on both manufacturers and installers.

The purpose is to ensure that customers are provided with the correct equipment for their needs, that it is installed, commissioned and serviced in accordance with the manufacturer's instructions by competent persons and that it meets the requirements of the appropriate Building Regulations. The Benchmark Checklist can be used to demonstrate compliance with Building Regulations and should be provided to the customer for future reference.

Installers are required to carry out installation, commissioning and servicing work in accordance with the Benchmark Code of Practice which is available from the Heating and Hotwater Industry Council who manage and promote the scheme.

Visit [centralheating.co.uk](http://centralheating.co.uk) for more information.

### Health and safety

The appliance contains no asbestos and no substances have been used in the construction process that contravene the COSHH Regulations (Control of Substances Hazardous to Health Regulations 1988).

### Combustion and corrosive materials

Do not store or use any combustible materials (paper, thinners, paints etc.) inside or within the vicinity of the appliance.

Chemically aggressive substances can corrode the appliance and invalidate any warranty.

### Fittings and modifications

Fitting the appliance and any controls to the appliance may only be carried out by a competent engineer in accordance with the current Gas Safety (Installation and Use) Regulations.

Flue systems must not be modified in any way other than as described in the fitting instructions. Any misuse or unauthorised modifications to the appliance, flue or associated components and systems could invalidate the warranty. The manufacturer accepts no liability arising from any such actions, excluding statutory rights.

### Servicing

Advise the user to have the system serviced annually by a competent, qualified Gas Safe registered engineer. Approved spares must be used to help maintain the economy, safety and reliability of the appliance.

### Important

The service engineer must complete the Service Record on the Benchmark Checklist after each service.

### FLUE SYSTEM



Only use the approved Worcester Condensfit II flue system with this appliance.

### WORCESTER ORIGINAL SPARE PARTS

Only use Worcester original spare parts with this appliance.

Non Worcester original spare parts will invalidate the guarantee (if applicable) and any warranty.

## 2 Regulations

### Installation regulations

Current Gas Safety (Installation & Use) Regulations:

All gas appliances must be installed by a competent person in accordance with the above regulations.

Failure to install appliances correctly could lead to prosecution.

The appliance must be installed in accordance with, and comply to, the current: Gas Safety Regulations, IET Regulations, Building Regulations, Building Standards (Scotland) (Consolidation), Building Regulations (Northern Ireland), local water by-laws, Health & Safety Document 635 (The Electricity at Work Regulations 1989), EU Regulations No. 811/2013 - Energy Labelling and any other local requirements.

### British standards

Where no specific instruction is given, reference should be made to the relevant British Standard codes of Practice.

|          |  |
|----------|--|
| BS7074:1 | Code of practice for domestic and hot water supply   |
| BS6891   | Installation of low pressure gas pipe work up to 28mm (R1)                                     |
| BS5546   | Installation of gas hot water supplies for domestic purposes                                   |
| EN12828  | Central heating for domestic premises  |
| BS5440:1 | Flues and ventilation for gas appliances of rated heating not exceeding 70kW (net): Flues      |
| BS5440:2 | Flues and ventilation for gas appliances of rated heating not exceeding 70kW (net): Air Supply |
| BS7593   | Treatment of water in domestic hot water central heating systems                               |
| BS6798   | Installation of gas fired boilers of rated input up to 70kW (net)                              |

### LPG Installations

An appliance using LPG must not be installed in a room or internal space below ground level unless one side of the building is open to the ground.

### Irish Standards

The relevant Irish standards should be followed, including:

- ECTI National rules for electrical installations
- IS 813:2002 for Domestic Gas Installations.

### Timber Framed Buildings

Where the boiler is to be fitted to a timber framed building the guidelines laid down in BS5440: Part 1 and IGE "Gas Installations in Timber Frame Buildings" should be adhered to.

### Potable Water

All seals, joints and compounds (including flux and solder) and components used as part of the secondary domestic water system must be approved by WRAS.

### CH Water

Artificially softened water must not be used to fill the central heating system.

### 3 APPLIANCE INFORMATION

#### 3.1 APPLIANCE

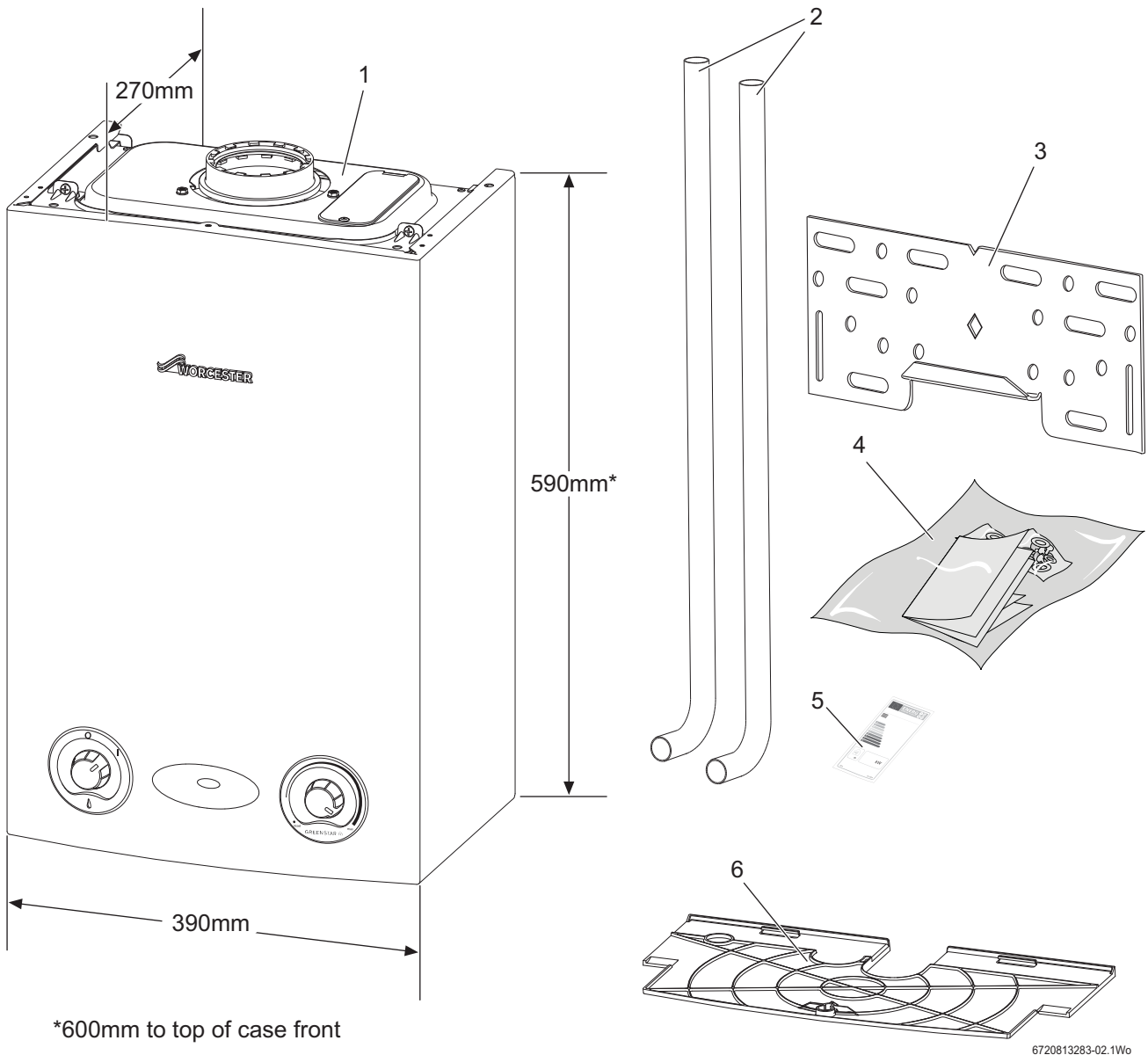

Fig. 1 Appliance



Do not use the pre-formed copper pipes supplied with the appliance for the gas supply. These copper pipes are for water only.

#### STANDARD PACKAGE:

|   |   |
|---|---|
| 1 | Wall hung gas fired condensing regular appliance for central heating and domestic hot water |
| 2 | Tail pipes - water only   |
| 3 | Wall plate  |
| 4 | Hardware literature pack (see checklist)  |
| 5 | ErP Label   |
| 6 | Bottom panel and wall mounting template   |

| CHECK LIST   | Qty. |
|--|------|
| <b>- HARDWARE LITERATURE PACK:</b>                               |      |
| Appliance Installation, Commissioning and Servicing Instructions | 1    |
| Users Instructions   | 1    |
| Consumer Guarantee Card  | 1    |
| Sealing Pack:  | 1    |
| - Compression Nut 22mm   | 3    |
| - Compression Ring 22mm  | 3    |
| Elbow assembly pack  | 1    |
| - Elbow Assembly   | 1    |
| - Fibre Washer   | 1    |

Table 4 Hardware lit pack - checklist

### 3.2 TECHNICAL DATA

#### Natural Gas Appliances

| DESCRIPTION  | UNIT              | NATURAL GAS                           |        |        |        |        |        |
|--|-------------------|---------------------------------------|--------|--------|--------|--------|--------|
|  |                   | 9kW                                   | 12kW   | 15kW   | 18kW   | 21kW   | 24kW   |
| <b>Gas flow rate - Max. 10 minutes from lighting</b>           |                   |                                       |        |        |        |        |        |
| Natural Gas G20  | m <sup>3</sup> /h | 0.95                                  | 1.30   | 1.63   | 1.96   | 2.26   | 2.60   |
| <b>Central Heating</b>   |                   |                                       |        |        |        |        |        |
| Max. rated heat input (net)                                    | kW                | 9.24                                  | 12.32  | 15.40  | 18.48  | 21.54  | 24.62  |
| Min. heat input  | kW                | 3.45                                  | 3.45   | 4.62   | 5.54   | 7.38   | 7.38   |
| Maximum rated heat output 40/30 °C                             | kW                | 9.64                                  | 12.85  | 16.06  | 19.28  | 22.47  | 25.67  |
| Maximum rated heat output 50/30 °C                             | kW                | 9.55                                  | 12.74  | 15.92  | 19.11  | 22.27  | 25.45  |
| Maximum rated heat output 80/60 °C                             | kW                | 9                                     | 12     | 15     | 18     | 21     | 24     |
| Maximum flow temperature                                       | °C                | 82                                    | 82     | 82     | 82     | 82     | 82     |
| Maximum possible flow temperature                              | °C                | 87                                    | 87     | 87     | 87     | 87     | 87     |
| Maximum permissible operating pressure                         | bar               | 2.5                                   | 2.5    | 2.5    | 2.5    | 2.5    | 2.5    |
| <b>Flue</b>  |                   |                                       |        |        |        |        |        |
| Flue gas temp. 80/60 °C, rated/min. load                       | °C                | 60/56                                 | 62/56  | 66/58  | 70/60  | 74/63  | 78/63  |
| Flue gas temp. 40/30 °C, rated/min. load                       | °C                | 38/33                                 | 41/33  | 44/33  | 48/34  | 51/35  | 54/35  |
| CO <sub>2</sub> level at max. rated heat output (after 30 min) | %                 | 9.6                                   | 9.6    | 9.6    | 9.6    | 9.6    | 9.55   |
| CO <sub>2</sub> level at min. rated heat output (after 30 min) | %                 | 8.6                                   | 8.6    | 8.6    | 8.6    | 8.6    | 8.55   |
| NOx class  |                   | 6                                     | 6      | 6      | 6      | 6      | 6      |
| NOx rating   | mg/kWh            | 36.0                                  | 38.6   | 44.3   | 48.7   | 55.5   | 56.0   |
| <b>Condensate</b>  |                   |                                       |        |        |        |        |        |
| Maximum condensate rate  | l/h               | 0.60                                  | 0.93   | 1.20   | 1.50   | 1.80   | 2.00   |
| pH value, approx.  |                   | 4.8                                   | 4.8    | 4.8    | 4.8    | 4.8    | 4.8    |
| <b>Electrical</b>  |                   |                                       |        |        |        |        |        |
| Electrical power supply voltage                                | A.C. V            | 230                                   | 230    | 230    | 230    | 230    | 230    |
| Frequency  | Hz                | 50                                    | 50     | 50     | 50     | 50     | 50     |
| Maximum power consumption                                      | W                 | 25                                    | 33     | 44     | 49     | 42     | 51     |
| <b>General data</b>  |                   |                                       |        |        |        |        |        |
| Appliance protection rating                                    | IP                | 20                                    | 20     | 20     | 20     | 20     | 20     |
| Permissible ambient temperatures                               | °C                | 0 - 50                                | 0 - 50 | 0 - 50 | 0 - 50 | 0 - 50 | 0 - 50 |
| Nominal capacity of appliance                                  | litre             | 1.1                                   | 1.1    | 1.1    | 1.1    | 1.1    | 1.1    |
| Packaged appliance weight                                      | kg                | 31                                    | 31     | 31     | 31     | 31     | 31     |
| Total appliance weight   | kg                | 27.4                                  | 27.4   | 27.4   | 27.4   | 27.4   | 27.4   |
| Lift weight  | kg                | 22.6                                  | 22.6   | 22.6   | 22.6   | 22.6   | 22.6   |
| SEDBUK 2005  | %                 | 89.8                                  | 89.8   | 89.7   | 89.7   | 89.6   | 89.6   |
| SEDBUK 2009  | %                 | 89.1                                  | 89.1   | 88.9   | 88.9   | 88.7   | 88.7   |
| Flue system  |                   | Category II 2H 3P type C13, C33 & C53 |        |        |        |        |        |

Table 5 Technical data Natural Gas

**LPG Appliances**

| DESCRIPTION  | UNIT   | LPG                                   |        |        |        |        |        |
|--|--------|---------------------------------------|--------|--------|--------|--------|--------|
|  |        | 9kW                                   | 12kW   | 15kW   | 18kW   | 21kW   | 24kW   |
| <b>Gas flow rate - Max. 10 minutes from lighting</b>           |        |                                       |        |        |        |        |        |
| Propane Gas (LPG)  | kg/h   | 0.71                                  | 0.96   | 1.20   | 1.44   | 1.77   | 1.91   |
| <b>Central Heating</b>   |        |                                       |        |        |        |        |        |
| Max. rated heat input (net)                                    | kW     | 9.24                                  | 12.32  | 15.40  | 18.48  | 21.54  | 24.62  |
| Min. heat input  | kW     | 5.95                                  | 5.95   | 5.95   | 9.64   | 9.64   | 9.64   |
| Maximum rated heat output 40/30 °C                             | kW     | 9.64                                  | 12.85  | 16.06  | 19.28  | 22.47  | 25.67  |
| Maximum rated heat output 50/30 °C                             | kW     | 9.55                                  | 12.74  | 15.92  | 19.11  | 22.27  | 25.45  |
| Maximum rated heat output 80/60 °C                             | kW     | 9                                     | 12     | 15     | 18     | 21     | 24     |
| Maximum flow temperature                                       | °C     | 82                                    | 82     | 82     | 82     | 82     | 82     |
| Maximum possible flow temperature                              | °C     | 87                                    | 87     | 87     | 87     | 87     | 87     |
| Maximum permissible operating pressure                         | bar    | 2.5                                   | 2.5    | 2.5    | 2.5    | 2.5    | 2.5    |
| <b>Flue</b>  |        |                                       |        |        |        |        |        |
| Flue gas temp. 80/60 °C, rated/min. load                       | °C     | 59/57                                 | 62/57  | 66/59  | 71/61  | 75/64  | 79/64  |
| Flue gas temp. 40/30 °C, rated/min. load                       | °C     | 40/35                                 | 43/35  | 46/36  | 49/37  | 52/37  | 55/38  |
| CO <sub>2</sub> level at max. rated heat output (after 30 min) | %      | 10.5                                  | 10.5   | 10.5   | 10.5   | 10.5   | 10.5   |
| CO <sub>2</sub> level at min. rated heat output (after 30 min) | %      | 10                                    | 10     | 10     | 10     | 10     | 10     |
| NOx class  |        | 6                                     | 6      | 6      | 6      | 6      | 6      |
| NOx rating   | mg/kWh | 36.0                                  | 38.6   | 44.3   | 48.7   | 55.5   | 56.0   |
| <b>Condensate</b>  |        |                                       |        |        |        |        |        |
| Maximum condensate rate  | l/h    | 0.5                                   | 0.7    | 0.9    | 1.2    | 1.4    | 1.5    |
| pH value, approx.  |        | 4.8                                   | 4.8    | 4.8    | 4.8    | 4.8    | 4.8    |
| <b>Electrical</b>  |        |                                       |        |        |        |        |        |
| Electrical power supply voltage                                | A.C. V | 230                                   | 230    | 230    | 230    | 230    | 230    |
| Frequency  | Hz     | 50                                    | 50     | 50     | 50     | 50     | 50     |
| Maximum power consumption                                      | W      | 26                                    | 36     | 52     | 55     | 44     | 54     |
| <b>General data</b>  |        |                                       |        |        |        |        |        |
| Appliance protection rating                                    | IP     | 20                                    | 20     | 20     | 20     | 20     | 20     |
| Permissible ambient temperatures                               | °C     | 0 - 50                                | 0 - 50 | 0 - 50 | 0 - 50 | 0 - 50 | 0 - 50 |
| Nominal capacity of appliance                                  | litre  | 1.1                                   | 1.1    | 1.1    | 1.1    | 1.1    | 1.1    |
| Packaged appliance weight                                      | kg     | 31                                    | 31     | 31     | 31     | 31     | 31     |
| Total appliance weight   | kg     | 27.4                                  | 27.4   | 27.4   | 27.4   | 27.4   | 27.4   |
| Lift weight  | kg     | 22.6                                  | 22.6   | 22.6   | 22.6   | 22.6   | 22.6   |
| SEDBUK 2005  | %      | 90.1                                  | 90.1   | 90.5   | 90.4   | 90.0   | 90.0   |
| SEDBUK 2009  | %      | 89.0                                  | 89.0   | 89.1   | 89.2   | 88.9   | 88.9   |
| Flue system  |        | Category II 2H 3P type C13, C33 & C53 |        |        |        |        |        |

*Table 6 Technical data LPG*

### 3.3 Energy efficiency

#### Natural Gas appliances

The following product data satisfy the requirements of the EU Regulations No. 811/2013 and No. 812/2013 supplementing Directive 2010/30/EU.

| Product data   | Symbol             | Unit   | 7733600306            | 7733600307             | 7733600308             | 7733600309             | 7733600310             | 7733600311             |
|--|--------------------|--------|-----------------------|------------------------|------------------------|------------------------|------------------------|------------------------|
| Product type   | –                  | –      | 9Ri <sup>EP+</sup> NG | 12Ri <sup>EP+</sup> NG | 15Ri <sup>EP+</sup> NG | 18Ri <sup>EP+</sup> NG | 21Ri <sup>EP+</sup> NG | 24Ri <sup>EP+</sup> NG |
| Condensing boiler  | –                  | –      | Yes                   | Yes                    | Yes                    | Yes                    | Yes                    | Yes                    |
| Low temperature boiler   | –                  | –      | No                    | No                     | No                     | No                     | No                     | No                     |
| B1 boiler  | –                  | –      | No                    | No                     | No                     | No                     | No                     | No                     |
| Cogeneration space heater (CHP)                                      | –                  | –      | No                    | No                     | No                     | No                     | No                     | No                     |
| Combination heater   | –                  | –      | No                    | No                     | No                     | No                     | No                     | No                     |
| Rated heat output  | P <sub>rated</sub> | kW     | 9                     | 12                     | 15                     | 18                     | 21                     | 24                     |
| Seasonal space heating energy efficiency                             | η <sub>s</sub>     | %      | 92                    | 92                     | 92                     | 92                     | 92                     | 92                     |
| Energy efficiency class  | –                  | –      | A                     | A                      | A                      | A                      | A                      | A                      |
| <b>Useful heat output</b>  |                    |        |                       |                        |                        |                        |                        |                        |
| At rated heat output and high temperature regime <sup>1)</sup>       | P <sub>4</sub>     | kW     | 9                     | 12                     | 15                     | 18                     | 21                     | 24                     |
| At 30% of rated heat output and low temperature regime <sup>2)</sup> | P <sub>1</sub>     | kW     | 4                     | 4                      | 5                      | 6                      | 8                      | 8                      |
| <b>Useful efficiency</b>   |                    |        |                       |                        |                        |                        |                        |                        |
| At rated heat output and high temperature regime <sup>1)</sup>       | η <sub>4</sub>     | %      | 87.2                  | 87.2                   | 86.9                   | 86.9                   | 86.7                   | 86.7                   |
| At 30% of rated heat output and low temperature regime <sup>2)</sup> | η <sub>1</sub>     | %      | 98.1                  | 98.1                   | 97.6                   | 97.6                   | 97.2                   | 97.2                   |
| <b>Auxiliary electricity consumption</b>                             |                    |        |                       |                        |                        |                        |                        |                        |
| At full load   | e <sub>l,max</sub> | kW     | 0.025                 | 0.033                  | 0.044                  | 0.049                  | 0.042                  | 0.051                  |
| At part load   | e <sub>l,min</sub> | kW     | 0.016                 | 0.016                  | 0.018                  | 0.018                  | 0.017                  | 0.017                  |
| In standby mode  | P <sub>SB</sub>    | kW     | 0.003                 | 0.003                  | 0.003                  | 0.003                  | 0.003                  | 0.003                  |
| <b>Other items</b>   |                    |        |                       |                        |                        |                        |                        |                        |
| Standby heat loss  | P <sub>stby</sub>  | kW     | 0.059                 | 0.059                  | 0.059                  | 0.059                  | 0.059                  | 0.059                  |
| Ignition burner power consumption                                    | P <sub>ign</sub>   | kW     | 0                     | 0                      | 0                      | 0                      | 0                      | 0                      |
| Emissions of nitrogen oxides   | NO <sub>x</sub>    | mg/kWh | 32                    | 35                     | 40                     | 44                     | 50                     | 51                     |
| Annual energy consumption  | Q <sub>HE</sub>    | kWh    | -                     | -                      | -                      | -                      | -                      | -                      |
| Sound power level, indoors   | L <sub>WA</sub>    | dB(A)  | 45                    | 45                     | 48                     | 50                     | 50                     | 50                     |

Table 7 Product data for energy consumption

1) High-temperature regime means 60 °C return temperature at heater inlet and 80 °C feed temperature at heater outlet.

2) Low temperature means for condensing boilers 30 °C, for low-temperature boilers 37 °C and for other heaters 50 °C return temperature (at heater inlet).

**LPG appliances**

The following product data satisfy the requirements of the EU Regulations No. 811/2013 and No. 812/2013 supplementing Directive 2010/30/EU.

| Product data   | Symbol             | Unit   | 7733600300               | 7733600301                | 7733600302                | 7733600303                | 7733600304                | 7733600305                |
|--|--------------------|--------|--------------------------|---------------------------|---------------------------|---------------------------|---------------------------|---------------------------|
| Product type   | -                  | -      | 9Ri <sup>ErP</sup> + LPG | 12Ri <sup>ErP</sup> + LPG | 15Ri <sup>ErP</sup> + LPG | 18Ri <sup>ErP</sup> + LPG | 21Ri <sup>ErP</sup> + LPG | 24Ri <sup>ErP</sup> + LPG |
| Condensing boiler  | -                  | -      | Yes                      | Yes                       | Yes                       | Yes                       | Yes                       | Yes                       |
| Low temperature boiler   | -                  | -      | No                       | No                        | No                        | No                        | No                        | No                        |
| B1 boiler  | -                  | -      | No                       | No                        | No                        | No                        | No                        | No                        |
| Cogeneration space heater (CHP)                                      | -                  | -      | No                       | No                        | No                        | No                        | No                        | No                        |
| Combination heater   | -                  | -      | No                       | No                        | No                        | No                        | No                        | No                        |
| Rated heat output  | P <sub>rated</sub> | kW     | 9                        | 12                        | 15                        | 18                        | 21                        | 24                        |
| Seasonal space heating energy efficiency                             | η <sub>s</sub>     | %      | 92                       | 92                        | 92                        | 92                        | 92                        | 92                        |
| Energy efficiency class  | -                  | -      | A                        | A                         | A                         | A                         | A                         | A                         |
| <b>Useful heat output</b>  |                    |        |                          |                           |                           |                           |                           |                           |
| At rated heat output and high temperature regime <sup>1)</sup>       | P <sub>4</sub>     | kW     | 9                        | 12                        | 15                        | 18                        | 21                        | 24                        |
| At 30% of rated heat output and low temperature regime <sup>2)</sup> | P <sub>1</sub>     | kW     | 6                        | 6                         | 6                         | 10                        | 10                        | 10                        |
| <b>Useful efficiency</b>   |                    |        |                          |                           |                           |                           |                           |                           |
| At rated heat output and high temperature regime <sup>1)</sup>       | η <sub>4</sub>     | %      | 87.2                     | 87.2                      | 86.9                      | 86.9                      | 86.7                      | 86.7                      |
| At 30% of rated heat output and low temperature regime <sup>2)</sup> | η <sub>1</sub>     | %      | 98.1                     | 98.1                      | 97.6                      | 97.6                      | 97.2                      | 97.2                      |
| <b>Auxiliary electricity consumption</b>                             |                    |        |                          |                           |                           |                           |                           |                           |
| At full load   | e <sub>l,max</sub> | kW     | 0.026                    | 0.036                     | 0.052                     | 0.055                     | 0.044                     | 0.054                     |
| At part load   | e <sub>l,min</sub> | kW     | 0.019                    | 0.019                     | 0.018                     | 0.023                     | 0.019                     | 0.019                     |
| In standby mode  | P <sub>SB</sub>    | kW     | 0.003                    | 0.003                     | 0.003                     | 0.003                     | 0.003                     | 0.003                     |
| <b>Other items</b>   |                    |        |                          |                           |                           |                           |                           |                           |
| Standby heat loss  | P <sub>stby</sub>  | kW     | 0.059                    | 0.059                     | 0.059                     | 0.059                     | 0.059                     | 0.059                     |
| Ignition burner power consumption                                    | P <sub>ign</sub>   | kW     | 0                        | 0                         | 0                         | 0                         | 0                         | 0                         |
| Emissions of nitrogen oxides   | NO <sub>x</sub>    | mg/kWh | 32                       | 35                        | 40                        | 44                        | 50                        | 51                        |
| Annual energy consumption  | Q <sub>HE</sub>    | kWh    | -                        | -                         | -                         | -                         | -                         | -                         |
| Sound power level, indoors   | L <sub>WA</sub>    | dB(A)  | 45                       | 45                        | 48                        | 50                        | 50                        | 50                        |

Table 8 Product data for energy consumption

1) High-temperature regime means 60 °C return temperature at heater inlet and 80 °C feed temperature at heater outlet.

2) Low temperature means for condensing boilers 30 °C, for low-temperature boilers 37 °C and for other heaters 50 °C return temperature (at heater inlet).

**3.4 APPLIANCE MAIN COMPONENTS**

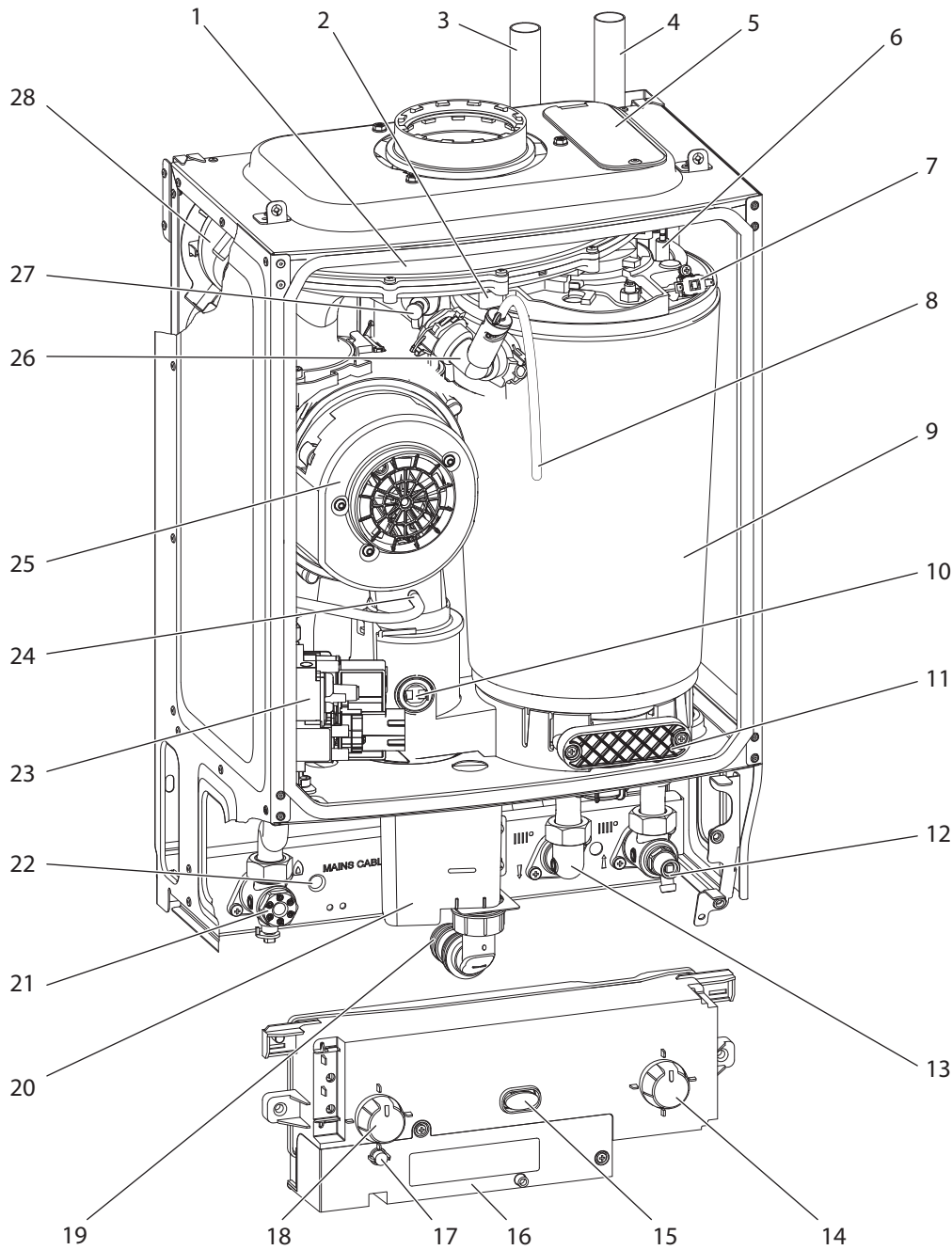

6720804541-01.1W6

|    |  |
|----|--|
| 1  | Air/Gas Manifold                             |
| 2  | Sensor - appliance flow                      |
| 3  | Flow pipe                                    |
| 4  | Return pipe                                  |
| 5  | Removable servicing panel                    |
| 6  | Electrode assembly                           |
| 7  | Overheat thermostat                          |
| 8  | Silicon tube - Heat Exchanger air vent       |
| 9  | Heat Exchanger                               |
| 10 | Flue overheat thermostat                     |
| 11 | Access panel - Heat Exchanger/Sump cleaning  |
| 12 | Return connector with drain point            |
| 13 | Flow connector                               |
| 14 | Appliance Temperature control and Reset knob |

|    |                                     |
|----|-------------------------------------|
| 15 | Power and fault indicator (blue)    |
| 16 | Wiring connections cover            |
| 17 | Burner indicator (green)            |
| 18 | Appliance ON/OFF switch             |
| 19 | Condensate connection               |
| 20 | Syphon / Trap                       |
| 21 | Gas inlet connection                |
| 22 | Mains cable inlet                   |
| 23 | Gas Valve                           |
| 24 | Flue air pressure switch connection |
| 25 | Fan                                 |
| 26 | Manual vent point                   |
| 27 | Fan pressure test point             |
| 28 | Air pressure switch                 |



## 4 PRE-INSTALLATION



**NOTICE:** All the following Pre-Installation sections must be read and requirements met before starting appliance or flue installations.



**CAUTION:** Isolate the mains supplies before starting any work and observe all relevant safety precautions.

### 4.1 MAINS SUPPLY

#### 4.1.1 ELECTRICAL SUPPLY

- Supply: 230V - 50 Hz, 140 Watts
- Cable: PVC insulated 0.75mm<sup>2</sup> (24 x 0.2mm) temp. rated to 90 °C.
- External 3A fuse to BS1362.
- The appliance must be earthed.
- Do not connected the appliance to a 3 phase supply.
- IP20.
- Wiring must comply with the latest edition of BS 7671 (IET wiring regulations).

#### 4.1.2 GAS SUPPLY

To ensure that the equipment is in good working order and can meet the gas flow and pressure requirements, in addition to the demand from any other appliance being served, the following applies:

- Appliances using Natural Gas (NG) must be connected to a governed meter.
- Liquid Petroleum Gas (LPG) must be connected to a regulator.
- Installation and connection of the gas supply to the appliance must be in accordance with BS6891.
- Gas pipe sizing should be calculated to ensure no more than the permitted mbar drop between the meter/governor to the appliance inlet. (→ Commissioning section).
- The meter or regulator and pipe work to the meter must be checked, preferably by the gas supplier.

## 4.2 WATER SYSTEMS AND PIPE WORK

### PLASTIC PIPE WORK:

- Any plastic pipe work must have a polymeric barrier with 600mm (minimum) length of copper pipe connected to the appliance.
- Plastic pipe work used for underfloor heating must be correctly controlled with a thermostatic blending valve limiting the temperature of the circuits to approximately 50 °C.

### PRIMARY SYSTEMS CONNECTIONS/VALVES:

- All system connections, taps and mixing valves must be capable of sustaining a pressure up to 3 bar.
- Radiator valves should conform to BS2767:10.
- All other valves should conform to BS1010.
- It is best practice to fit Thermostatic Radiator Valves (TRV's) to all radiators except the area where the room thermostat is sited which must be fitted with lockshield valves that are left open.
- If the circulating pump speed is fixed and system circulation can be significantly adjusted or stopped by TRV's or zone valves, a system bypass should be installed to give at least a 3 metre circuit when activated. However; any appliance fitted with a modulating pump may not require a system bypass.
- A drain cock is required at the lowest point in the system.
- An air vent is required at all high points in the system.



**NOTICE:** To prevent reverse circulation

- ▶ The cylinder return must be the last connection on the common return pipe.



**NOTICE:** Artificially softened water must not be used to fill the central heating system.



Pump speed characteristics

- ▶ In order to save as much energy as possible and the minimise the possibility of water circulation noise. The circulating pump should be selected and adjusted to suit the system resistance.

### OPEN VENT PRIMARY SYSTEM CONSIDERATIONS:

- The open vent pipe and feed and expansion pipe must rise continuously from the appliance.
- Close coupled feed and expansion pipe maximum separation of 150mm.
- The feed and expansion cistern must be positioned to provide a minimum static head of 250mm above the highest point in the heating system to the water level in the feed and expansion cistern.
- Ensure adequate space is left in the expansion cistern for expansion of the system water.
- No valve shall be fitted in the open vent pipe or the feed and expansion pipe.
- The open vent pipe must be at least 22mmØ.
- **Do not use galvanised pipes or radiators.**

### SEALED PRIMARY SYSTEM CONSIDERATIONS:

- The CH sealed system must be filled using a WRAS approved filling loop or comply with figure 3 for system fill.
- An expansion vessel, of a size suitable for the system, must be fitted as close as possible to the appliance in the central heating return.
- Also fit a pressure gauge, a 3 bar pressure relief valve and stop cock (fixed cylinder type or sealed system approved connection).
- No valve shall be fitted that can isolate the appliance from the expansion vessel or pressure relief valve.
- An automatic air vent must be fitted.
- **Do not use galvanised pipes or radiators.**

**SYSTEM FILL**

**SYSTEM FILL**

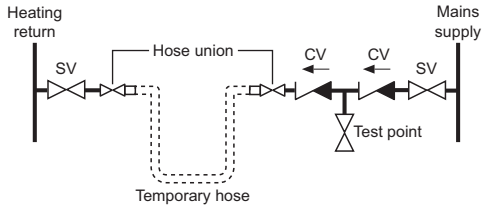

CV = Check Valve  
SV = Stop Valve  
AA = Auto Air vent  
CV = Check Valve

**SYSTEM MAKE UP**

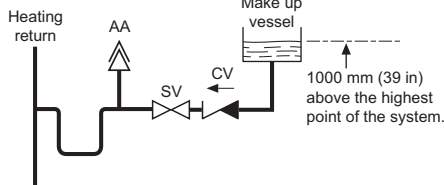

6720644743-08.2W0

Fig. 3 System fill/System make-up

**S AND Y PLAN SYSTEMS:**

**NOTICE:** Bypass considerations  
▶ Appliances fitted with a modulating pump may not require a system bypass.

|    |   |
|----|---|
| 1  | Static head - Minimum static head 250mm measured from the highest point in the heating system (top surface of the appliance or the highest point in the heating system) to the water level in the feed and expansion tank |
| 2  | Heating vent (22mm minimum)   |
| 3  | Primary cold feed (15mm minimum)  |
| 4  | Diverter/Zone valve   |
| 5  | Pump, maximum power 90 Watts  |
| 6  | Automatic bypass  |
| 7  | Radiator valve (Flow)   |
| 8  | Lock shield valve (Return)  |
| 9  | Expansion vessel  |
| 10 | Pressure gauge  |
| 11 | 3 bar pressure relief valve   |
| 12 | Stop cock   |

Table 9 Key to figures 4, 5, 6, 7 & 8

**NOTICE:** A drain cock should be fitted at the lowest point of the heating circuit and beneath the appliance.

**SYSTEM LAYOUTS EXAMPLES:**

**S PLAN LAYOUT - OPEN VENT**

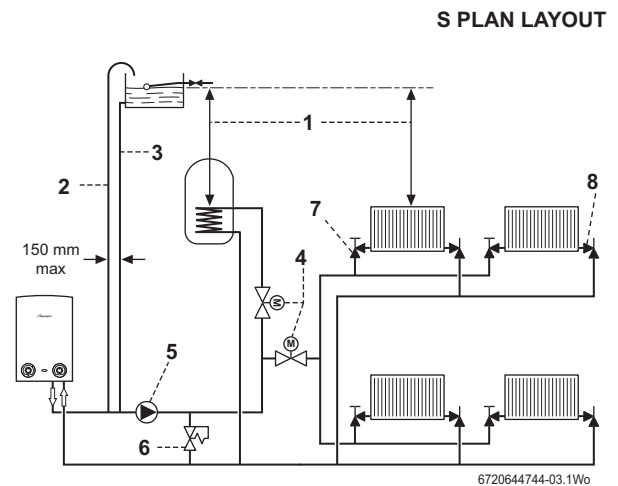

Fig. 4 S plan open vent

**Y PLAN LAYOUT - OPEN VENT**

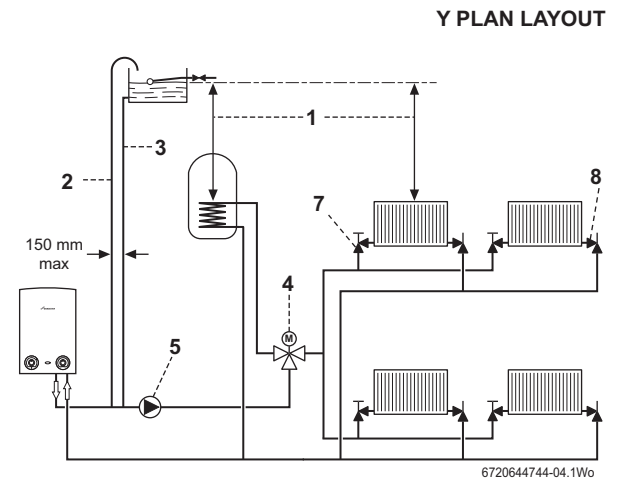

Fig. 5 Y plan open vent

**SEALED SYSTEM Y PLAN LAYOUT**

The central heating sealed system must be filled using a WRAS approved filling loop or comply with figure 3 for System fill.

**SEALED SYSTEM LAYOUT**

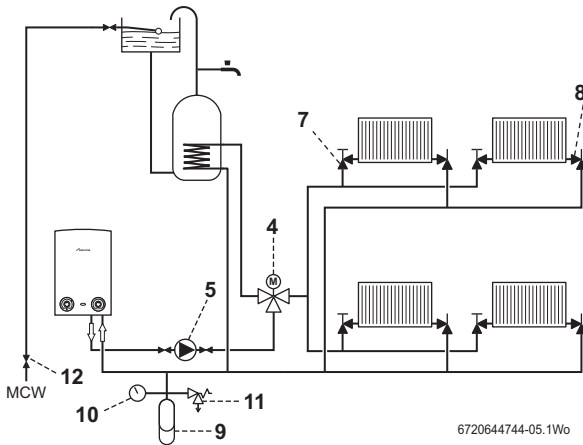

Fig. 6 Y plan sealed system

**NEW BUILD SYSTEM LAYOUTS**

The latest Part L 1a regulation for new installations require separate zone controls for the central heating.

**Open vent with two heat zones**

**OPEN VENT LAYOUT**

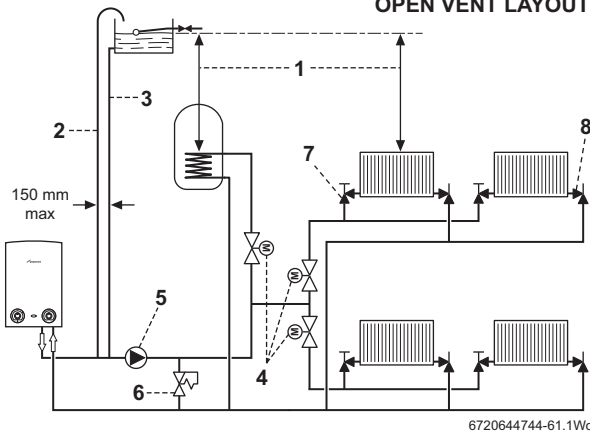

Fig. 7 Two heating zones open vent

**Sealed system with two heat zones**

**SEALED SYSTEM LAYOUT**

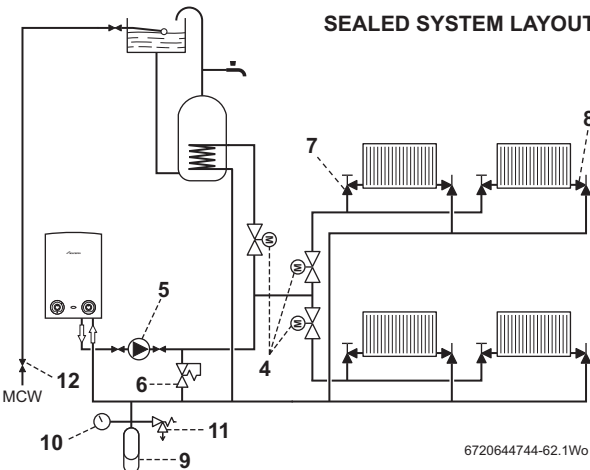

Fig. 8 Two heating zones sealed system

**4.3 Condensate discharge**



- Full details on condensate discharge.
- Follow the latest version of **BS6798** and HHIC guidance.

For correct installation and trouble free operation of the appliance the following advice should be followed:

- All condensate pipework must 'fall' from the appliance by a minimum of 3 degrees (52mm per metre) to ensure adequate Condensate flow.
  - The pipework route must allow air to be supplied back to the appliance for correct operation of the siphon.
  - Connection to a rainwater down pipe must include an air break.
- Also:

- Keep external pipework as short as possible and not exceed 3 metres length.
- External pipework should be increased to a minimum diameter of 32mm and ideally be insulated.
- Minimise the number of bends and connectors.
- Remove burrs after cutting pipe.
- Remove surplus solvent from the interior of the pipe.

**4.3.1 CONDENSATE PIPE WORK**



**NOTICE:**

- Where a new or replacement appliance is being installed, access to an internal "gravity discharge" point should be one of the factors considered in determining appliance location.
- The condensate pipe must be nominally 22mm Ø plastic pipe.
- The condensate pipe work must fall at least 52mm per metre towards the outlet and should take the shortest practicable route.
- Ensure there are no blockages in the pipe run.



**NOTICE: Unheated internal areas.**

- Although the large volume siphon will reduce the risk of freezing, condensate discharge may freeze in areas of prolonged cold temperatures.
- Internal pipe runs in unheated areas such as lofts, basements and garages should be treated as external runs.

Key to condensate illustrations, figures 9, 10, & 11

|   |  |
|---|--|
| 1 | Condensate discharge from appliance    |
| 2 | Soil and vent stack                    |
| 3 | Minimum 450mm and up to three storeys  |
| 4 | Visible air break at plug hole         |
| 5 | Sink or basin with integrated overflow |
| 6 | 75mm sink waste trap                   |
| 7 | Condensate pump                        |

Table 10 Key to Internal condensate disposal methods

**4.3.2 INTERNAL CONNECTIONS**

In order to minimise risk of freezing during prolonged cold spells, the following methods of installing condensate drainage pipe should be adopted, in order of priority.

Wherever possible, the condensate drainage pipe should be routed and terminated so that the condensate drains away from the appliance under gravity to a suitable internal foul water discharge point such as an internal soil and vent stack. A suitable permanent connection to the foul waste pipe should be used.

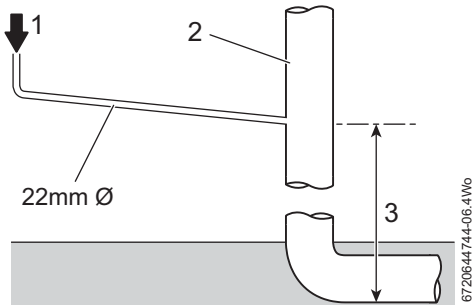

Fig. 9 Disposal to soil vent stack

Alternatively if the first option is not possible an internal kitchen, bathroom or washing machine waste pipe etc. can be used. Ensure that the condensate drain pipe is connected “down stream” of the waste trap.

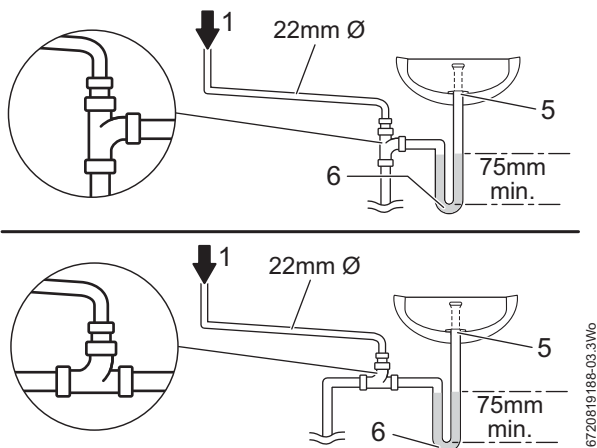

Fig. 10 Disposal to a waste pipe

**CONDENSATE PUMP**

Where “gravity discharge” to an internal termination is not physically possible, or where very long internal runs would be required to reach a suitable discharge point, condensate should be removed using a proprietary condensate pump, of a specification recommended by the appliance or condensate pump manufacturer.

The pump outlet pipe should discharge to a suitable internal foul water discharge point such as an internal soil and vent stack or if not possible to internal kitchen, bathroom or washing machine waste pipe etc. A suitable permanent connection to the foul waste pipe should be used.

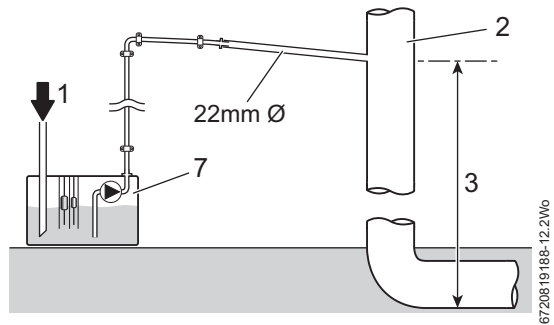

Fig. 11 Condensate pump disposal

**4.3.3 External connection considerations**

**NOTICE:** Rainwater or external drain disposal  
Untreated condensate must not be allowed to flow into streams or rivers

- ▶ A rainwater down pipe or an external drain shall only be used for condensate disposal if the down pipe or external drain is connected to a combined foul and rainwater system
- ▶ Refer to BS 6798 for more information

**NOTICE:** Grey water systems  
Contamination of recovered water

- ▶ Condensate disposal shall not be allowed into a grey water recovery system that is intended for re-use

**NOTICE:** Freezing conditions

- ▶ Pipe work length should be kept to a minimum and the route as vertical as possible.
- ▶ When required, use only weather proof insulation.

**NOTICE:** Condensate waste

- ▶ Care should be taken when siting a soak-away to avoid causing damage to existing services.

**Continued - Key to condensate illustrations, figures 12, 13, 14 & 15**

|    |   |
|----|---|
| 1  | Condensate discharge from appliance                                       |
| 7  | Condensate pump   |
| 8  | Pipe work transition  |
| 9  | Insulate and increase pipe size   |
| 10 | External rain water pipe into foul water                                  |
| 11 | External air break  |
| 12 | Air gap   |
| 13 | Strap-on fitting  |
| 14 | 43mm 90° male/female bend   |
| 15 | 100mm Ø minimum plastic pipe  |
| 16 | Drainage holes  |
| 17 | Limestone chippings   |
| 18 | Bottom of sealed tube   |
| 19 | Increase size of soak away with limestones chippings if in clay soil area |

Table 11 Key to external condensate disposal methods

**i** Condensate drainage pipe can be run above or below ground. If the pipe work is run under ground, care must be taken to ensure that the pipe work "fall" towards the disposal point is maintained

If no other discharge method is possible then the use of an externally run condensate drainage pipe terminating at a suitable foul water discharge point, or purpose-designed soak away, may be considered. If this method is chosen then the following measures should be adopted:

- ▶ Use a CondenseSure siphon to help prevent the condensate freezing.
- ▶ The external run be kept as short as possible and not exceed 3 metres.
- ▶ The pipe should be run internally as far as possible before going externally and the pipe diameter should be increased to 32mm before it passes through the wall to the exterior. The pipe should be insulated using suitable waterproof and weather resistant insulation, if not using a CondenseSure siphon.
- ▶ The external pipe should take the shortest and least exposed route to the discharge point, and should "fall" as steeply as possible away from the appliance, with no horizontal runs in which condensate might stand.

- ▶ The use of fittings, elbows etc. should be kept to a minimum and any internal "burrs" on cut pipe work should be removed so that the internal pipe section is as smooth as possible.

**FITTING AN EXTERNAL AIR BREAK**

- Refer to figure 12 when a rain water down pipe is used to dispose of condensate.
- An air break must be installed in the 43mm pipe work, between the appliance condensate outlet and the drainpipe, outside the property, to avoid flooding during adverse weather conditions.

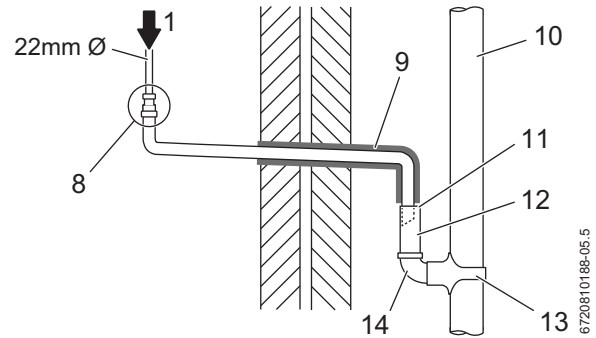

Fig. 12 Disposal into a rainwater down pipe

Where the pipe terminates over an open drain or gully, the pipe should terminate below the grating level, but above water level, in order to minimise "wind chill" at the open end.

The use of a drain cover (such as those used to prevent blockage by leaves) may offer further protection from wind chill.

Pipe drainage will be improved if the end is cut at 45° as opposed to a straight cut.

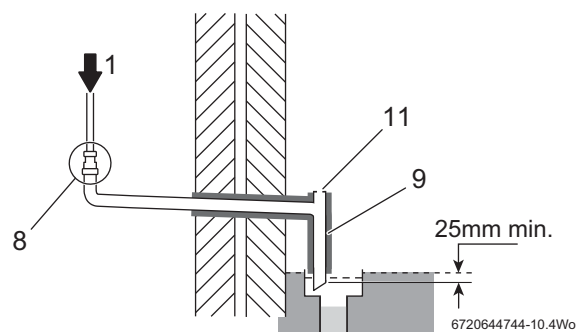

Fig. 13 External disposal

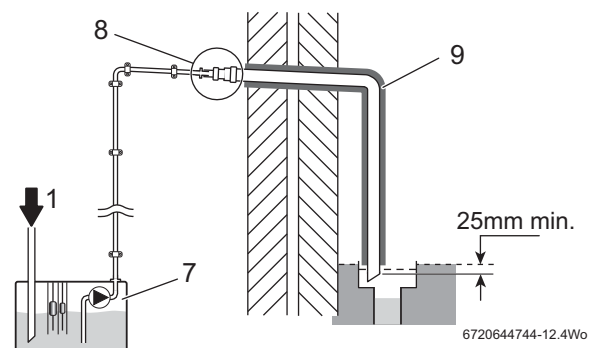

Fig. 14 Condensate pump to external disposal

**CONDENSATE SOAK AWAY**

- The condensate soak away must be sited at least 500mm away from building footings.
- The condensate drainage pipe may be run above or below the ground to the soak away. The examples shown on this page run above ground.
- The soak away must use a 100mm Ø plastic tube with two rows of three 12mm holes on 25mm centres and 50mm from the bottom of the tube. The holes must face away from the house.
- The tube must be surrounded by at least 100mm of limestone chippings to a depth of 400mm.



Minimum hole size for the condensate soak away must be 400mm deep by 300mmØ.

In situations where there are likely to be extremes of temperature or exposure, the use of a proprietary trace-heating system for external pipe work, incorporating an external frost thermostat, should be considered. If such a system is used, the requirement to use 32mm pipe does not apply. However, all other guidance above and the instructions for the trace heating system, should be closely followed.



**NOTICE:** Unheated internal areas.

- ▶ Internal pipe runs in unheated areas such as lofts, basements and garages should be treated as external runs and consideration should be given to using a CondenseSure siphon.

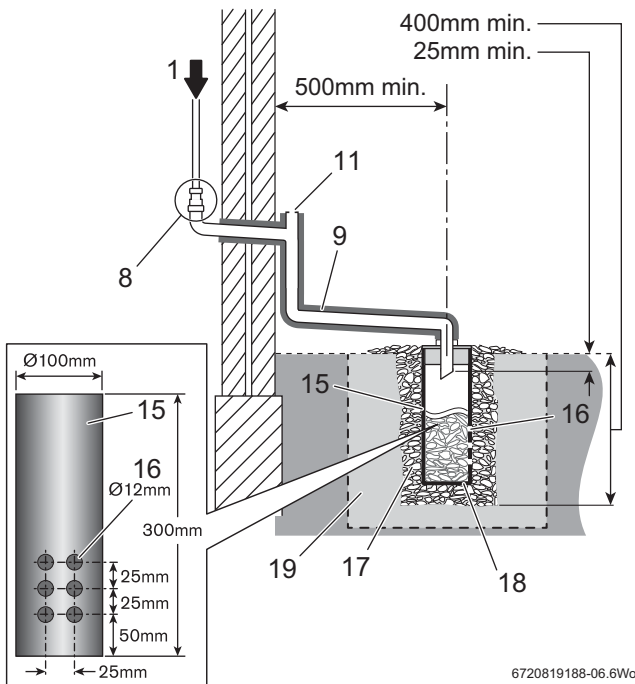

Fig. 15 To a soakaway

**4.4 PRESSURE RELIEF PIPE WORK**



**NOTICE:**

- ▶ The pressure relief valve is a safety device for the appliance and if activated may discharge boiling water or steam through the relief valve drain pipe.
- ▶ Care should be taken when siting the outlet pipe so that it does not cause an obstruction or discharge above a window, entrance or other public access where it could cause a hazard.

- The pressure relief discharge pipe [1 or 3] should be run in at least 15mm diameter copper pipe or pipe made of a material that will withstand PRV discharge temperatures and pressures and which complies to BS 5252 or BS EN 1451.
- The connection to the PRV must be made in copper pipe. Plastic pipe work must be properly supported with a maximum of 300mm between supports to prevent sagging and run downwards away from the appliance.
- The pressure relief should discharge away from any electrical or other hazard, preferably to an external drain or soak away.
- Pipe [1 or 3] should be finished with a partial bend, near the outlet to face the external wall (as shown) to help prevent freezing.

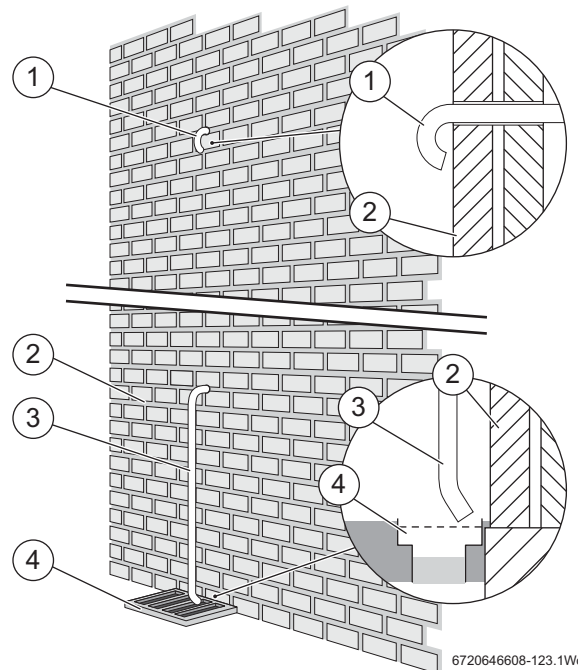

Fig. 16 Pressure relief pipe work

- [1] Discharge pipe (turned back onto external wall example)
- [2] Outside wall
- [1] Discharge pipe (into drain or gully example)
- [4] External drain

**4.4.1 Alternative PRV connections - Combined PRV/condensate**

The PRV or a combined PRV/ condensate discharge can be connected into a suitable internal waste system, the installer must ensure that all the pipe work, including the waste pipe, is capable of withstanding PRV temperatures and pressures.

Worcester, Bosch Group endorses a PRV or a combined PRV/ Condensate internal discharge system, provided that a Hotun hiflo tundish is employed. The tundish is manufactured by RA Tech UK and is WRAS approved, information on the tundish can be found at [www.hotun.co.uk](http://www.hotun.co.uk).

The guidance of BS 6798 sections 6.3.5 and 6.4.3.2a and RA Tech UK and must be followed.

## 4.5 APPLIANCE LOCATION AND CLEARANCES

### 4.5.1 Installation

This appliance is only suitable for installing internally within a property at a suitable location onto a fixed, rigid surface at least the same size as the appliance and capable of supporting the appliance weight.



No surface protection is required against heat transfer from the appliance.

The appliance must be installed where:

- An engineer can gain clear and safe access to work on the product or component, including making adequate provision for visual inspection of flues in voids.
- The homeowner can gain clear and safe access to the controls, check, top up or reset the appliance.
- Products in loft cavities must have permanent fixed lighting, a permanent fixed retractable ladder and a fixed floor area sufficient to allow access for normal use and servicing directly under and around the product and between and the access hatch.

### 4.5.2 SERVICING CLEARANCES - VENTILATED COMPARTMENT

Figure 17 shows the minimum space required to install and service the appliance in a ventilated compartment.

- If a appliance is installed in a compartment with clearances less than shown in the tables 14, 15, or 16 ventilation is required. Refer to table 12 for ventilation requirements.

| Vent position | To room or internal space         | Direct to outside                   |
|---------------|-----------------------------------|-------------------------------------|
| High level    | Min. free area 122cm <sup>2</sup> | Minimum free area 61cm <sup>2</sup> |
| Low level     | Min. free area 122cm <sup>2</sup> | Minimum free area 61cm <sup>2</sup> |

Table 12 Compartment ventilation

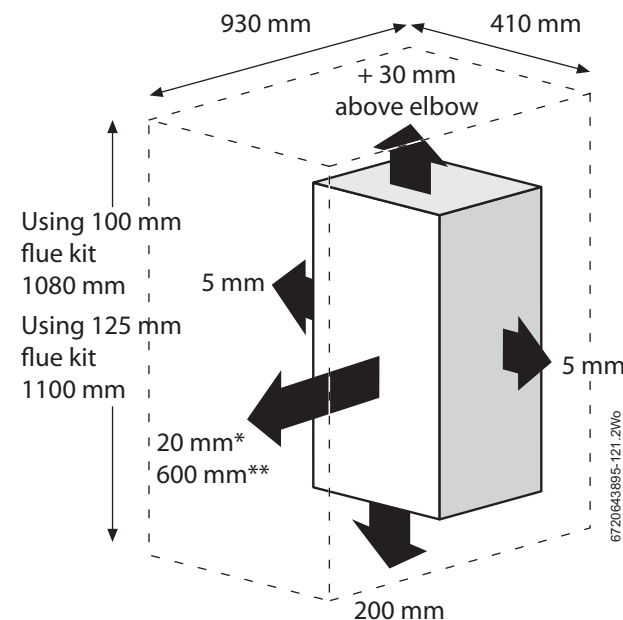

Fig. 17 Ventilated compartment

|    |  |
|----|--|
| *  | Minimum clearance to removable door      |
| ** | Minimum clearance required for servicing |

Table 13 Minimum clearances

### 4.5.3 COMPARTMENTS:

Follow the requirements of BS6798 and BS5440 Part 2 and note:

- Minimum clearances must be maintained.
- An access door is required to install, service and maintain the appliance and any ancillary equipment.
- If the appliance is installed in an unventilated airing/storage cupboard, there is no requirement to make a partition between the appliance and the storage space as long as the minimum clearances around the appliance are maintained.
- Ideally, storage should be below the appliance, where the appliance is mounted in the upper part of the cupboard, whilst maintaining the clearances given in tables 14, 15, or 16.

### 4.5.4 APPLIANCE CLEARANCES- UNVENTILATED COMPARTMENTS

The tables below show the options for the minimum space required to install and service the appliance inside an unventilated compartment.

### 4.5.5 INSTALLATION CLEARANCES - UNVENTILATED COMPARTMENTS

**CAUTION: CLEARANCES**

▶ Top and bottom clearances must not be reduced below the values shown in table 14 as they are the minimum clearances required for servicing.

| Unventilated Compartment Installation Clearances (millimetres)   |                                     |       |                           |
|--|-------------------------------------|-------|---------------------------|
| Suggested total unventilated compartment minimum clearances are: |                                     |       |                           |
| Side   | Above                               | Below | Front (to removable door) |
| 400mm  | 170mm approx.<br>(30mm above elbow) | 200mm | 100mm                     |

Table 14 Minimum unventilated compartment clearances

| If Side Clearances are Reduced (millimetres)  |   |  |
|---|---|--|
| If total side clearance is reduced to: (Combined left and right clearances excluding the appliance) | Increase height clearances to (approx.): (Combined top & bottom clearances excluding the appliance) | OR Front clearance (to removable door) must be increased to: |
| 350   | 441   | 129  |
| 300   | 523   | 161  |
| 250   | 617   | 200  |
| 200   | 717   | 243  |
| 150   | 856   | 295  |
| 100   | 1012  | 358  |
| 50  | 1202  | 434  |

Table 15 Reduced side clearances

| If Front Clearance is Reduced (millimetres)           |   |   |
|---|---|---|
| If front clearance (to removable door) is reduced to: | Increase overall height clearances to (approx.): (Combined top and bottom clearances excluding the appliance) | OR Increase total side clearance to: (Combined left and right clearances excluding the appliance) |
| 50mm  | 511mm   | 505mm   |
| 25mm  | 596mm   | 569mm   |

Table 16 Reduced front clearances

**4.5.6 ROOMS CONTAINING A BATH OR SHOWER**

 **NOTICE:** Any switch or appliance control using mains electricity must not be within reach of a person using the bath or shower.

- The installation **must be in accordance with the latest edition of the IET Wiring Regulations BS7671.**
- Circuit breaking devices should be used in accordance with the regulations.
- The diagram is for guidance only.

The appliance must only be installed outside zone 2.

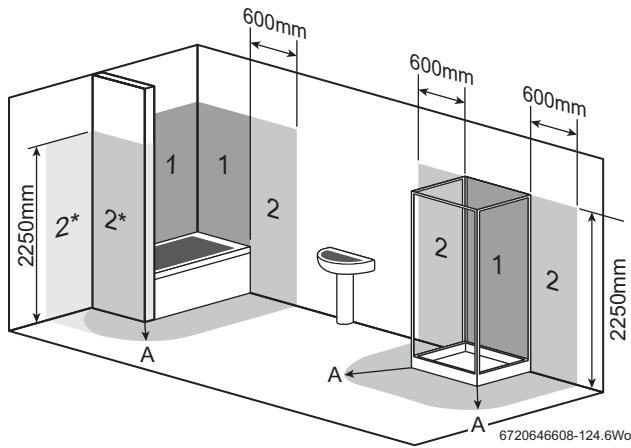

*Fig. 18 Bathroom installations*

- [1] Zone 1
- [2] Zone 2
- [2\*] Without the end wall, zone 2 must extend 600mm from the bath
- [A] 600mm radius from bath or shower

## 4.6 PLUMBING MANIFOLD

### 4.6.1 CONNECTIONS

|                |                           |
|----------------|---------------------------|
| Heating System | 22mm compression fittings |
| Gas            | 22mm compression fittings |

Use the fittings supplied in the Hardware literature pack:

**i** Do not use the pre-formed copper pipes supplied with the appliance for the gas supply. These copper pipes are for water only.

- Use the 22mm copper pipes (1 & 2) provided with the appliance, as shown in the diagram opposite.
- If the flow and return pipes are to be run behind the appliance it maybe an advantage to connect the pipes before hanging on the wall especially if space is limited.

**i** Further guidance on pipe routing can be found printed on the appliance template (supplied with the appliance).  
 ▶ Ensure that the pipes are adequately supported and room between the pipes to avoid noise.

| # | Function             | From left case edge | Diameter of pipe |
|---|----------------------|---------------------|------------------|
| 1 | Gas                  | 55mm                | 22mm             |
| 2 | Condensate           | 210mm               | 22mm             |
| 3 | Cylinder & CH Flow   | 285mm               | 22mm             |
| 4 | Cylinder & CH Return | 350mm               | 22mm             |

Table 17 Key to figures 19 & 20

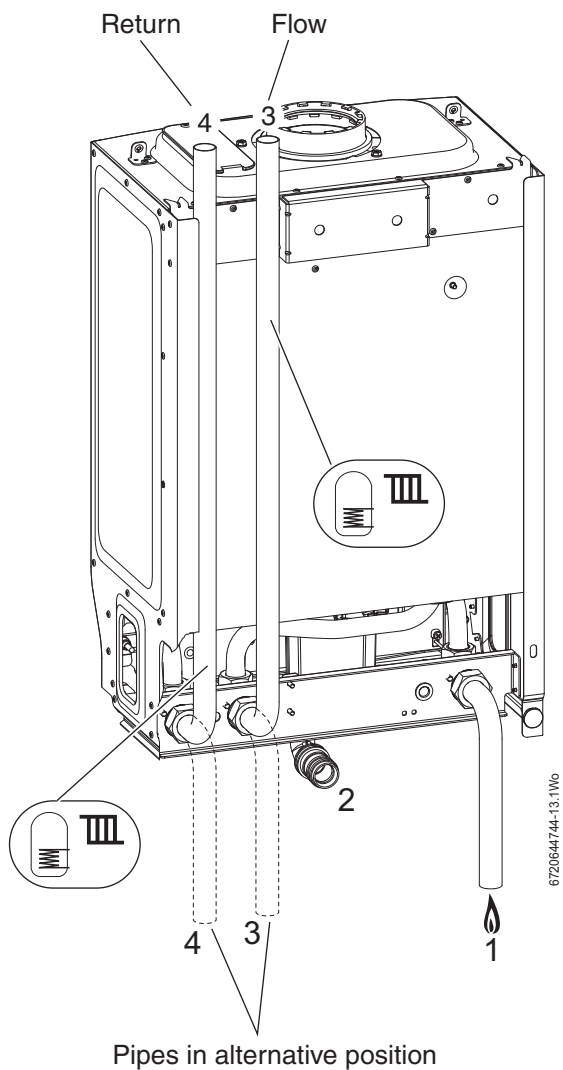

Fig. 19 Plumbing manifold



Fig. 20 Pipe work dimensions

## 4.7 FLUE OPTIONS

**WARNING:** Flue systems

- ▶ Only use Worcester, Bosch approved flue systems, no other manufacturer's flue systems have been approved for use with Worcester appliances.

**CAUTION:** Non accessible flue systems:

- ▶ Where a flue system is not going to be accessible, provision must be made for service and inspection.
- ▶ Voids containing concealed flues must have at least one inspection hatch no less than 300mm square.
- ▶ Flue joints within the void must not be more than 1.5 metres from the edge of the inspection hatch.
- ▶ Inspection hatches should be located at changes of direction.
- ▶ If this is not possible, bends should be viewable from both directions.

**NOTICE:** Effective flue lengths:

- ▶ each 90° bend is equivalent to 2 metres of straight flue
- ▶ each 45° bend is equivalent to 1 metre of straight flue

**i** Plume management kits are available for the 60/100 horizontal flue system.  
Refer to the manual supplied with the plume management kits for complete installation instructions

| Part number   | Flue   | Description                                |
|---------------|--------|--|
| 7 716 191 082 | 60/100 | Telescopic horizontal flue assembly        |
| 7 716 191 171 | 60/100 | Longer telescopic horizontal flue assembly |
| 7 733 600 048 | 60/100 | Horizontal high level telescopic flue kit  |
| 7 719 003 702 | 80/125 | Telescopic horizontal flue assembly        |
| 7 719 002 430 | 60/100 | Vertical flue assembly                     |
| 7 719 002 431 | 80/125 | Vertical flue assembly                     |

Table 18 Flue kit part numbers

### 4.7.1 Flue lengths

The flue systems have different maximum flue lengths

The Greenstar series has the option of two horizontal 60/100 RSF (telescopic and longer telescopic) and one horizontal 80/125 RSF (telescopic) flue system and two vertical RSF (60/100 or 80/125) flue systems:

Refer to the following example Flue options for the maximum flue lengths.



#### Horizontal high level flue assembly

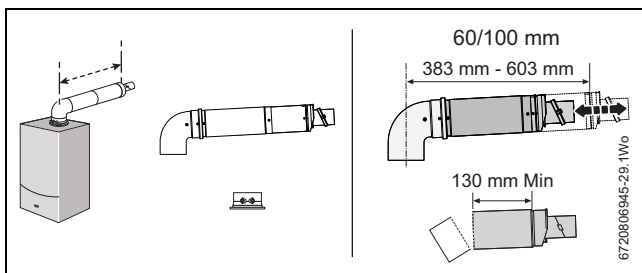

|  | Flue length (mm) |        |
|--|------------------|--------|
|  | 60/100           | 80/125 |
| Horizontal high level telescopic flue assembly | 202 - 603        | N/A    |

Table 19

#### TELESCOPIC HORIZONTAL FLUE ASSEMBLY

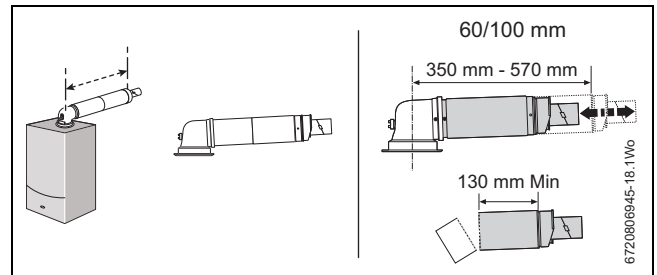

|  | Flue length (mm) |           |
|--|------------------|-----------|
|  | 60/100           | 80/125    |
| Telescopic horizontal flue assembly        | 180 - 570        | 405 - 600 |
| Longer telescopic horizontal flue assembly | 570 - 790        | N/A       |

Table 20

#### Extended horizontal flue

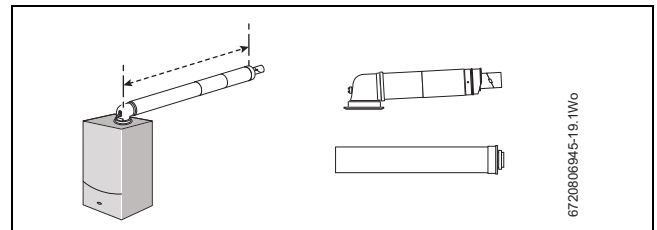

|                          | Maximum flue length (mm) |        |
|--------------------------|--------------------------|--------|
|                          | 60/100                   | 80/125 |
| Extended horizontal flue | 4,600                    | 13,000 |

Table 21

#### Horizontal flue with additional elbow (1 x 90° bend)

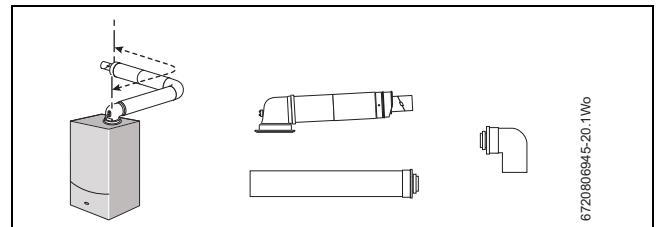

|                                   | Maximum flue length (mm) |        |
|-----------------------------------|--------------------------|--------|
|                                   | 60/100                   | 80/125 |
| Horizontal flue with 1 x 90° bend | 2,600                    | 11,000 |

Table 22

#### Horizontal flue with additional elbows (2 x 90° bends)

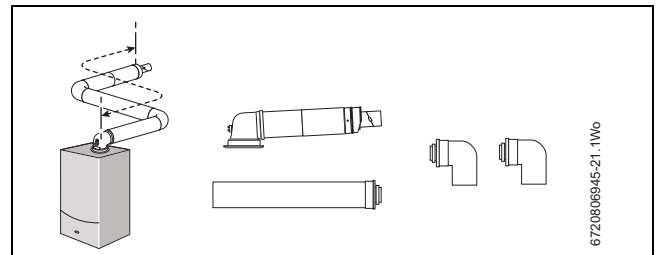

|                                    | Maximum flue length (mm) |        |
|------------------------------------|--------------------------|--------|
|                                    | 60/100                   | 80/125 |
| Horizontal flue with 2 x 90° bends | N/A                      | 9,000  |

Table 23

**High level horizontal flue**

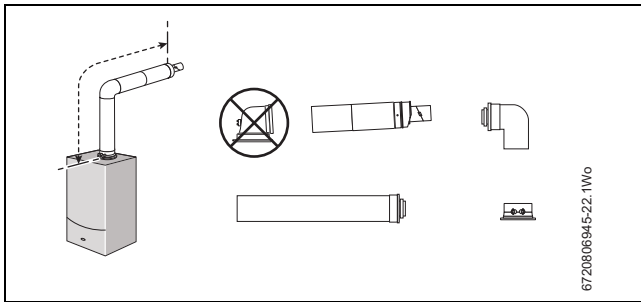

|                            | Maximum flue length (mm) |        |
|----------------------------|--------------------------|--------|
|                            | 60/100                   | 80/125 |
| High level horizontal flue | 4,600                    | 13,000 |

Table 24

**High level horizontal flue with additional elbows**

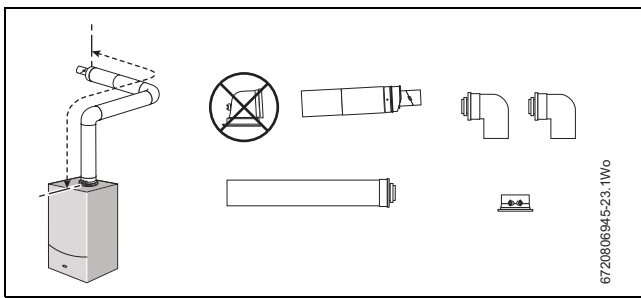

|   | Maximum flue length (mm) |        |
|---|--------------------------|--------|
|   | 60/100                   | 80/125 |
| High level horizontal flue with 2 x 90° bends | 2,600                    | 11,000 |

Table 25

**High level horizontal flue with additional elbows**

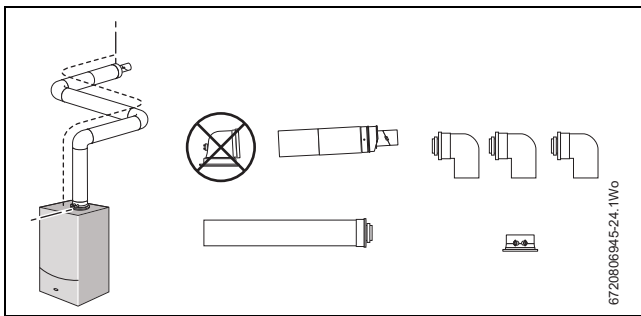

|   | Maximum flue length (mm) |        |
|---|--------------------------|--------|
|   | 60/100                   | 80/125 |
| High level horizontal flue with 3 x 90° bends | N/A                      | 9,000  |

Table 26

**Vertical balanced flue assembly**

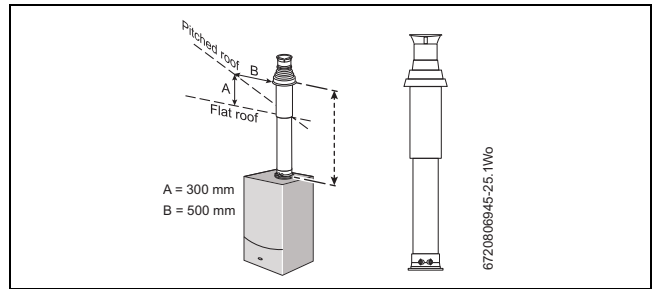

|                                 | Maximum flue length (mm) |        |
|---------------------------------|--------------------------|--------|
|                                 | 60/100                   | 80/125 |
| Vertical balanced flue assembly | 6,400                    | 15,000 |

Table 27

**Vertical balanced flue with elbow offset (2 x 90° bends)**

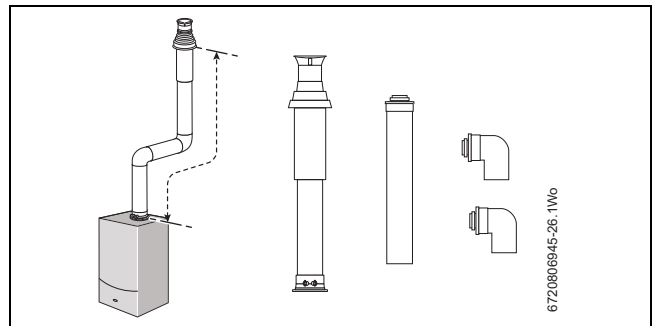

|   | Maximum flue length (mm) |        |
|---|--------------------------|--------|
|   | 60/100                   | 80/125 |
| Vertical balanced flue with 2 x 90° bends | 2,400                    | 11,000 |

Table 28

**Vertical balanced flue with elbow offset (2 x 45° bends)**

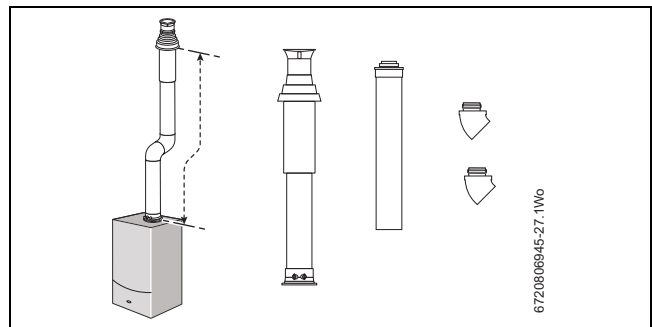

|   | Maximum flue length (mm) |        |
|---|--------------------------|--------|
|   | 60/100                   | 80/125 |
| Vertical balanced flue with 2 x 45° bends | 4,400                    | 13,000 |

Table 29

## 4.8 Flue terminal positions

**CAUTION:**  
**Flue terminal positions**

- ▶ All measurements are the minimum clearances required.
- ▶ Terminals must be positioned so to avoid combustion products entering the building.

### 4.8.1 Vertical flue terminal positions

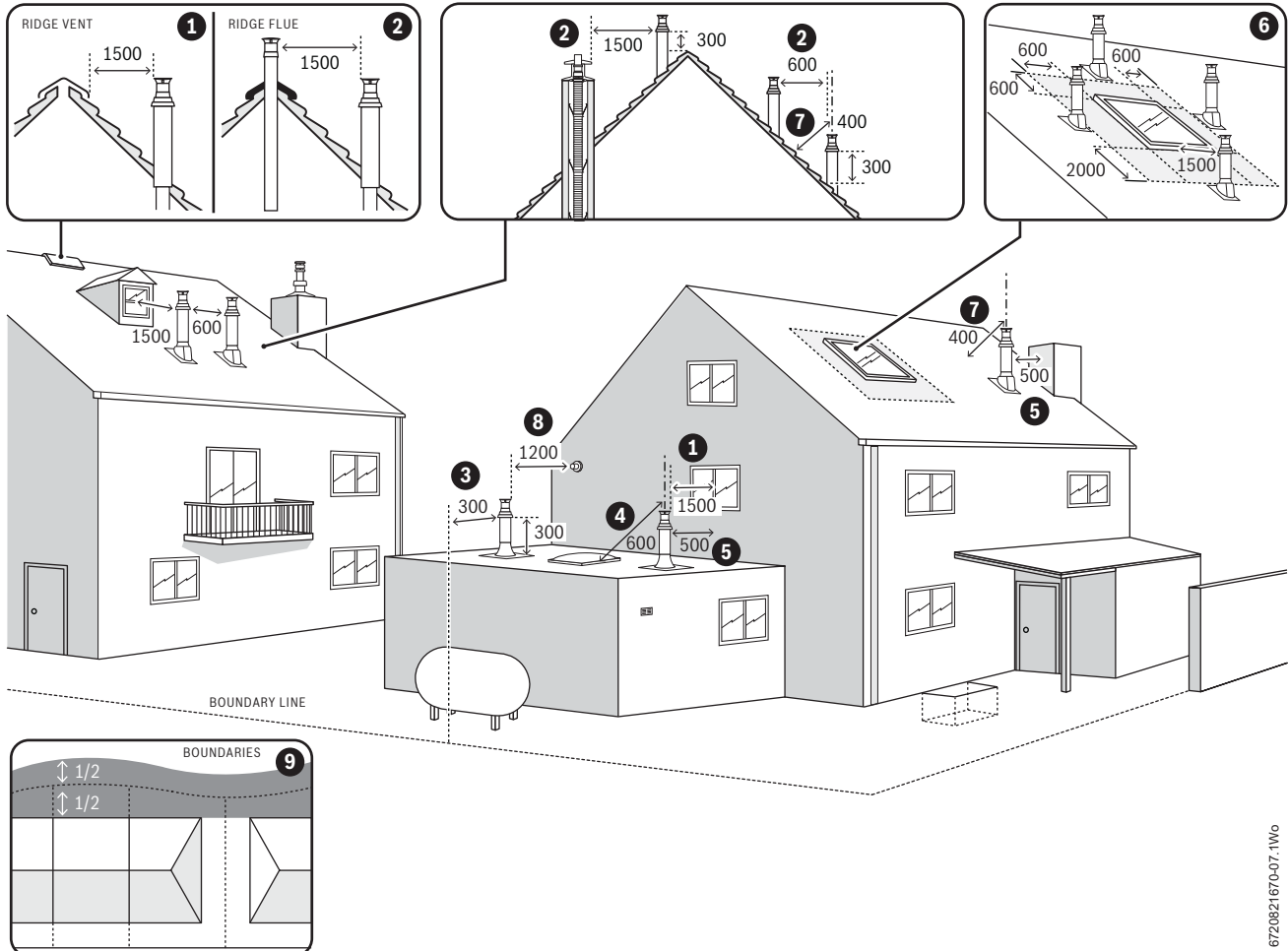

Fig. 21 Vertical flue terminal positions

#### Key to figure 21:

- [1] 1,500mm measured horizontally between a vertical flue terminal and an opening or vented window. 500mm measured horizontally between a vertical flue terminal and an opening or vented window providing the flue terminal is at least 300mm above the opening.
- [2] Minimum clearance to an additional flue, 600mm to a room sealed flue or 1,500mm to an open flue.
- [3] 300mm clearance from a vertical flue terminal adjacent to a boundary line, unless it will cause a nuisance. BS 5440: Part 1 recommends that care is taken when siting a terminal in relation to boundary lines.
- [4] 600mm minimum clearance measured from an opening or vented skylight to a vertical flue terminal. If the terminal is within 1,500mm of the opening or vented skylight then it must be at least 300mm above the opening.
- [5] 500mm clearance measured horizontally from a vertical flue to a vertical structure.
- [6] The flue must not penetrate the roof in the shaded area. The terminal must be at least 1500mm from the opening or vent when sited below the window or 600mm when sited to either side or above.
- [7] 400mm from a pitched roof or 500mm in regions with heavy snow fall.
- [8] 1,200mm separation between a vertical flue measured horizontally and a horizontal flue terminal. Not required if the horizontal flue is 1,200mm above.
- [9] For the purpose of determining suitable flue terminal positions for gas appliances, the boundary can be considered to extend to the centre line of any adjacent routes or waterways e.g. paths, streets, rights of way, canals, rivers or railways.



#### Note:

- ▶ Where a vertical flue terminates in an area that is enclosed on 3 sides, the flue must be no more than 1,000mm below the lowest roof line. You must ensure that all clearances are maintained and that products of combustion disperse safely from the area.

4.8.2 Horizontal flue terminal positions

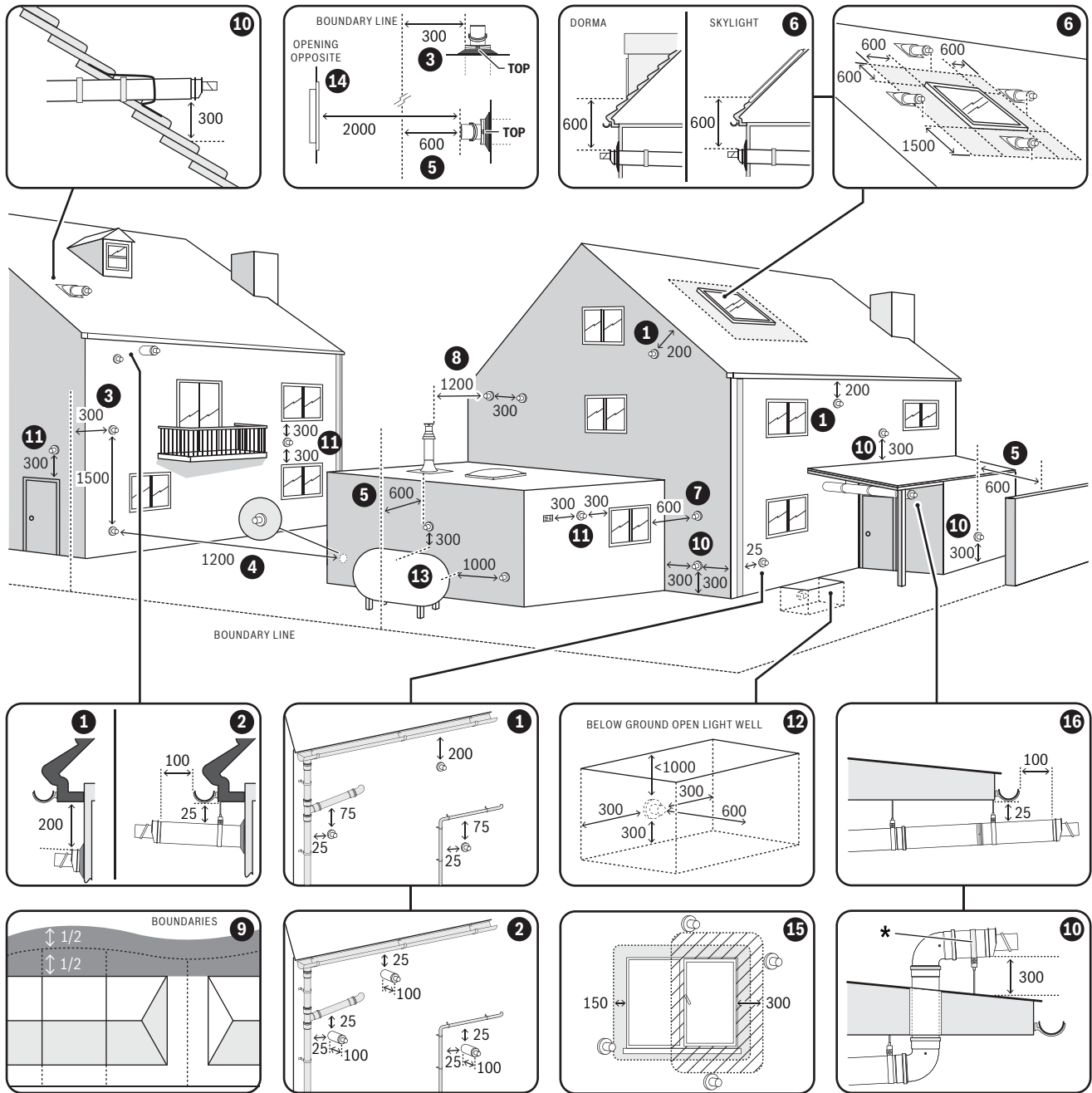

6720821670-08.1W0

Fig. 22 Horizontal flue terminal positions

**Key to Figure 22:**

- [1] 200mm below eaves and 75mm below gutters, pipe and drains.
- [2] The dimension below eaves, gutters, pipes and drains can be reduced to 25mm, as long as the flue terminal is extended by 100mm past any overhang. The telescopic flue joint must be sealed with suitable silicone sealant if it is external to the building.
- [3] 300mm adjacent to a boundary line, unless it will cause a nuisance. BS 5440: Part 1 recommends that care is taken when siting terminal in relation to surfaces or boundary lines.
- [4] 1,200mm separation measured between terminals facing each other.
- [5] 600mm distance to a surface or boundary line facing a terminal, unless it will cause a nuisance. BS 5440: Part 1 recommends that care is taken when siting terminal in relation to surfaces or boundary lines.
- [6] The terminal must be at least 1500mm from the opening or vent when sited below the window or 600mm when sited to either side or above.
- [7] 600mm diagonally to an opening door, air vent or opening window.
- [8] 1,200mm separation between a vertical flue measured horizontally and a horizontal flue terminal.  
Not required if the horizontal flue is 1,200mm above.
- [9] For the purpose of determining suitable flue terminal positions for gas appliances, the boundary can be considered to extend to the centre line of any adjacent routes or waterways e.g. paths, streets, rights of way, canals, rivers or railways.
- [10] 300mm to an internal or external corner. 300mm above a surface, such as the ground/ floor level or roof surface.  
\* If the terminal section is less than 150mm and has two screws securing it to the elbow, the terminal section will not require a supporting bracket.
- [11] 300mm above, below and either side of an opening door, air vent or opening window.
- [12] Below ground level in an open lightwell. The flue must be at least 600mm from the opposing surface and have at least 300mm clearance either side and below. The flue terminal must be no more than 1000mm from the top of the lightwell.
- [13] Flues should clear any LPG storage by 1,000mm horizontally and 300mm above.
- [14] Proximity of flue duct outlet to boundaries, 2000mm distance to an opening in adjacent building facing a terminal. BS 5440: Part 1 recommends that care is taken when siting terminal in relation to boundary lines.
- [15] 300mm from an opening or vented window, 150mm to a fixed unvented window.
- [16] The dimension below eaves, balconies and car ports can be reduced to 25mm, as long as the flue terminal is extended to clear any overhang. The telescopic flue joint of the terminal must be sealed with suitable silicon sealant if it is external to the building.



**Note:**

- ▶ Installations in car ports are not recommended.
- ▶ The flue cannot be lower than 1,000mm from the top of a light well due to the build up of combustion products.
- ▶ Dimensions from a flue terminal to a fanned air inlet to be determined by the ventilation equipment manufacturer.
- ▶ A flue terminal guard shall be fitted whenever a terminal or air inlet is fitted less than 2,000mm above ground, above a balcony or above a flat roof to which people have access.

**4.8.3 Plume re-direct and plume management terminal positions**



Maximum and minimum plume management lengths:

- ▶ A minimum distance of 500mm must be maintained between the plume management outlet and the flue air intake.
- ▶ The maximum plume management length is 4.5 metres for the appliances detailed on the front of this manual.
- ▶ The 45° bend is equivalent to 0.75 metres of straight plume management and the 90° bend is equivalent to 1.5 metres.



**NOTICE:**

- ▶ All measurements are the minimum clearances required.
- ▶ Refer to “Horizontal flue terminal positions” for all concentric flue terminal positions unless the flue position is specified in figure 23 for “Plume re-direct and plume management terminal positions”.
- ▶ Terminals must be positioned so to avoid combustion products entering the building.
- ▶ Support the flue at approximately one metre intervals and at a change of direction, use suitable brackets and fittings.

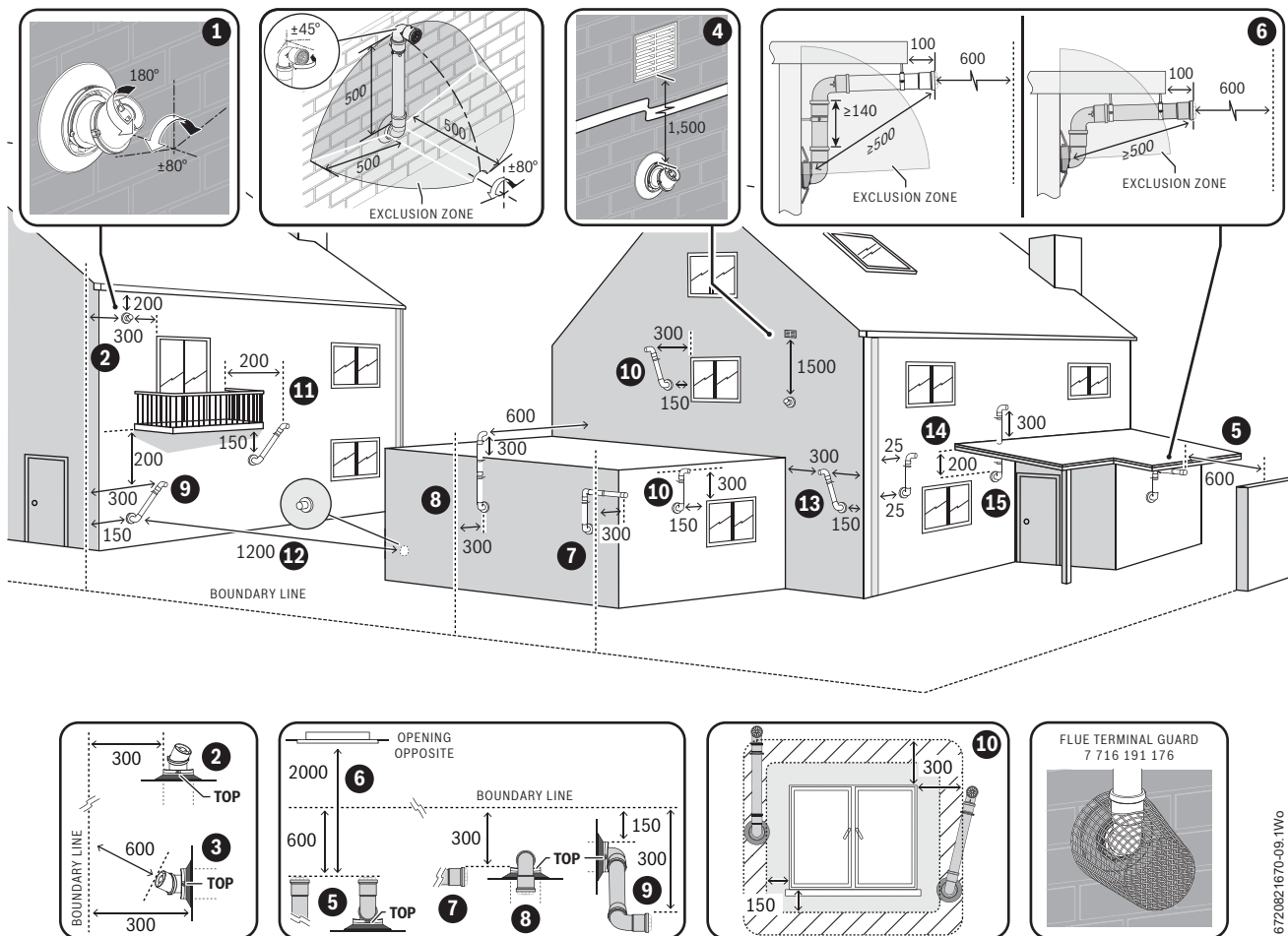

Fig. 23 Plume re-direct and plume management terminal positions

6720821670-09-1Wo

**Key to Figure 23 - Plume re-direct terminal positions:**

- [1] This feature allows some basic plume re-direction options on a standard telescopic horizontal flue terminal.  
300mm minimum clearances to an opening e.g. window.  
However the minimum clearances to an opening in the direction that the plume management is facing, must be increased to 1,500mm.  
Where the flue is less than 150mm to a drainpipe and plume redirection is used the deflector should not be directed towards the drainpipe.
- [2] 300mm adjacent to a boundary line, unless it will cause a nuisance. BS 5440: Part 1 recommends that care is taken when siting terminal in relation to surfaces or boundary lines.
- [3] Where the flow of products of combustion is not at right angles to the boundary, the 600mm dimension may be measured in the direction of flow as long as the terminal is not less than 300mm from the boundary.
- [4] When redirecting the flue discharge the terminal end must be at least 1,500mm from any opening in the direction of the discharge to prevent combustion products from entering the building.

**Key to Figure 23 - Plume management terminal positions:**

- [5] 600mm distance to a surface or a boundary line, unless it will cause a nuisance. BS 5440:Part 1 recommends that care is taken when siting a terminal in relation to surfaces or boundary lines.
- [6] Proximity of flue duct outlet to boundaries, 2000mm distance to an opening in adjacent building facing a terminal. BS 5440: Part 1 recommends that care is taken when siting terminal in relation to boundary lines.
- [7] 300mm adjacent to a boundary line, unless it will cause a nuisance. BS 5440: Part 1 recommends that care is taken when siting terminal in relation to surfaces or boundary lines.
- [8] 300mm distance from a boundary line to the air intake as long as the exhaust terminal faces away from the boundary line. The exhaust terminal must have a minimum 300mm clearance to a surface below and there must be at least 600mm clearance when measured horizontally in a straight line from the exhaust terminal to any other surface.
- [9] Plume Management kit air intake can be reduced to 150mm providing the flue exhaust outlet is no less than 300mm adjacent to a boundary line.
- [10] Above, below and either side of an opening door, air vent or opening window.  
Using a Plume Management kit the air intake measurement can be reduced to 150mm providing the flue exhaust outlet has a 300mm clearance.
- [11] Below balcony or overhang. The air intake clearance can be reduced to 150mm providing the flue exhaust outlet has a 200mm clearance.
- [12] 1,200mm between terminals facing each other.
- [13] Internal/external corners. The air intake clearance can be reduced to 150mm providing the flue exhaust outlet has a 300mm clearance.
- [14] Clearances no less than 200mm from the lowest point of the balcony or overhang.

- [15] If a plume management kit is installed within the confines of a carport or other covered, partially enclosed extension, then the exhaust terminal must be positioned at least 1200mm away from any opening into the building which is sited within the footprint of the carport.

If the exhaust terminal is extended at least 300mm beyond the footprint of the carport then the distance from the terminal to an opening within the carport can be reduced to 600mm.

The exhaust terminal can also be routed though the roof of the carport providing 25mm clearance is provided around the flue pipe to any flammable material and that it extends at least 300mm above the roof.

The air intake must have a minimum 150mm clearance to any opening in the building in order to ensure the integrity of the structure is maintained. If the exhaust terminates within the footprint of the carport then the carport must have at least 2 sides completely open. If the exhaust terminates at least 300mm beyond the footprint of the carport then the carport must have at least one completely open side. The exhaust terminal must be positioned to ensure that plume will not cause nuisance or damage to vehicles and that minimum clear distances in front of the terminal will not be impeded by vehicles.



**Note:**

- ▶ Installations in car ports are not recommended.
- ▶ The flue cannot be lower than 1,000mm from the top of a light well due to the build up of combustion products.
- ▶ Dimensions from a flue terminal to a fanned air inlet to be determined by the ventilation equipment manufacturer.
- ▶ Plume kits running horizontally must have at least a 3° fall back to the appliance for proper disposal of condensate, except or the initial horizontal run from the terminal.  
The initial plume kit horizontal run will have at least a 10° fall back to the appliance, due to the terminal elbow design, for proper disposal of the condensate.

## 4.9 CLEANING PRIMARY SYSTEMS



**NOTICE:** Debris from the system can damage the appliance and reduce efficiency.

Failure to comply with the guidelines for the use of water treatment with the appliance will invalidate the appliance guarantee and contravene the Building Regulations.

- ▶ It is a requirement of the Building Services Compliance Guide which is a second tier document to the Building Regulations to flush and inhibit the primary water system in accordance with BS 7593.
- ▶ The Building Services Compliance Guide recommends that a primary water cleanser is fitted to the system.
- ▶ Worcester Bosch recommend fitting a filter that will help remove both magnetite and non-magnetic debris.
- ▶ Worcester offers two filters that helps remove both magnetite and non-magnetic debris; 22mm version, part number 7 733 600 236 and a 28mm version, part number 7 733 600 237.



**NOTICE: Risk of damage to system or appliance!**

Artificially softened water must not be used to fill the central heating system.

- ▶ Salt based, artificially softened water **MUST NOT** be used to fill the system.



**NOTICE: Sealing agents**

When an appliance is installed onto a new system.

- ▶ In cases where all attempts to find a system micro leak have failed, Worcester, Bosch Group supports the use of Fernox F4 leak sealer.

### Before cleaning the system:

- ▶ Ensure that the system and pipe work is in good working order.
- ▶ **Where possible keep the existing appliance/circulating pump in place when flushing the system before installing the new appliance. Alternatively use an after market power flushing system or similar to remove magnetite and other debris from the central heating system.**
  - Even new central heating systems contain contaminants that need to be removed before treating the system with inhibitor/antifreeze.
  - When an appliance is installed onto a new system then it is possible to use the appliance whilst cleaning the system. There is a risk that debris could damage the appliance and reduce efficiency. A system filter must be fitted to the return to reduce the risk of contaminants entering the appliance.
- ▶ **Follow the guidance of BS7593.**

### Inhibitor

Add a suitable inhibitor or combined inhibitor/anti-freeze, if the system is exposed to freezing conditions, to the heating system in accordance with the DWTA code of practice and manufacturer's guidelines.

Products approved to the BuildCert standard are deemed as compatible with the components and equipment within the appliance and system.



**WARNING: Sealing agents**

- ▶ The addition of sealing agents to the system water is not permitted as this can cause problems with deposits left in the heat exchanger.
- ▶ In cases where all attempts to find a micro leak have failed, Worcester, Bosch Group supports the use of Fernox F4 leak sealer.

### Water treatment products

Suitable water treatment products can be obtain from the following manufacturers:

|          |   |
|----------|---|
| ADEY     | 01242 546717<br>www.adey.com                |
| FERNOX   | 0870 601 5000<br>www.fernox.com             |
| SENTINEL | 0800 389 4670<br>www.sentinel-solutions.net |

Table 30

### 4.9.1 Flushing the system

- ▶ Fill the system with cold water and check for leaks.
- ▶ **Open vented systems only:**
  - Turn off the water to the system header tank.
- ▶ Open all drain cocks and drain the system.
- ▶ Close drain cocks and add a suitable flushing agent **compatible with aluminium** at the correct strength for the system conditions in accordance with the manufacturer's instructions.
 

**The pH value of the system water must be between 6.5 and 8 or the appliance guarantee will be invalidated.**
- ▶ Mark the position of the lockshield valves and open them fully.
- ▶ Fully open all TRVs.
- ▶ Circulate the flushing agent before the appliance is fired up.
- ▶ Run the appliance/system at normal operating temperature as directed by the manufacturer of the flushing agent.
- ▶ Drain and thoroughly flush the system to remove the flushing agent and debris. Do not drain the system through the PRV of new appliances.
- ▶ It may be necessary to use a power flushing machine to aid the cleansing procedure in some circumstances.
- ▶ Close the drain cocks and manual air vents.
- ▶ **Existing appliance/circulating pump if continuing to use before new appliance is installed.**
  - Add a suitable inhibitor to the system in accordance with the manufacturers instructions.
  - **Open vented systems only:** Turn on the water to the system header tank and allow the system to fill.
  - **Sealed systems only:** Fill the system to between 1 and 1.5 bar via a WRAS approved filling loop.
  - Vent any air from the appliance and system.
- ▶ **New appliance.**
  - Once the new appliance has been installed follow the guidance in Filling the appliance and adding inhibitor section.

## 5 INSTALLATION

**WARNING:** All the previous "Pre-Installation" sections must be read and the requirements met before starting appliance or flue installation.

### 5.1 UNPACKING THE WALL FRAME & ANCILLARY ITEMS

**CAUTION: LIFTING AND CARRYING**

- ▶ Only lift a manageable weight, or ask for help.
- ▶ Bend the knee and keep the back straight with feet apart, when lifting or putting down heavy objects.
- ▶ DO NOT lift and twist at the same time.
- ▶ Lift and carry object close to the body.

**i** Do not use the pre-formed water pipes on the gas supply, they must only be used for water.

Remove the straps and open the top of the appliance packaging.

1. Remove the two 22mm water pipes (1)
2. Remove the following items:
  - Wall mounting plate (2).
  - Wall mounting template and bottom panel (3).
  - Literature pack and pipe connectors and olives (4).
  - ErP label (5)

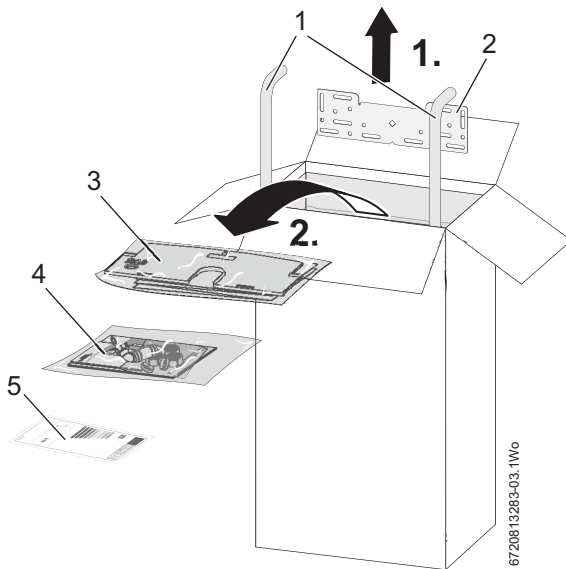

Fig. 24 Unpacking 1

3. Remove the top carton (5).
4. Remove the outer cardboard sleeve (6).
5. Remove the plastic cover (7).

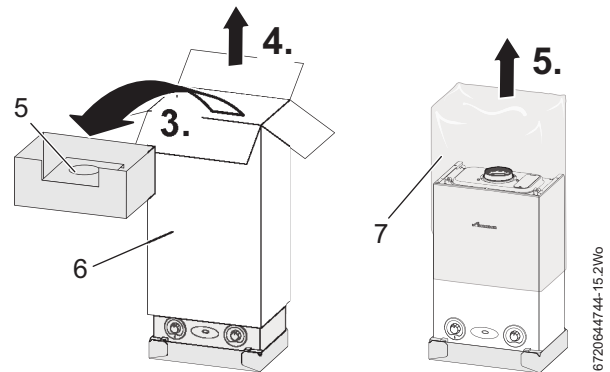

Fig. 25 Unpacking 2

- ▶ Flatten the outer cardboard sleeve and place on the floor behind the appliance.
- ▶ Lay the appliance on its back on the cardboard.
- ▶ Remove the bottom tray.

#### IMPORTANT HANDLING INSTRUCTIONS:

- It is advised that two people are used to carry the carton from the van to the point of delivery.
- Once the carton has been delivered, remove the outer carton. Care should be taken when releasing the straps. If a sharp implement is used, ensure the outer carton is not pierced and that the implement is used in such a way that it will not cause personal injury.
- All sharp objects must be covered or the blade retracted after use and put away in a safe place. The wall mounting frame, Installer pack, template and bottom panel can now be removed. Care should be taken when lifting the appliance from the base and the proper technique for safe lifting of any heavy object must be strictly observed.

#### Additional requirements for roof space installation:

- The appliance must be unpacked before ascending the steps to loft space.
- Two sets of steps should be used.
- Two people should share the lifting of the appliance up to the loft hatch, where the appliance is entered into the loft space, tilted, and slid on its back into the loft.
- Once the appliance is removed from its packaging check the contents against the packing list.

**Before installing the appliance, ensure that the system has been cleaned as explained on page 30.**

## 5.2 POSITION THE APPLIANCE

**WARNING:**

- ▶ Ensure the mains gas supply is isolated before starting any work and follow all relevant safety precautions.

**i** Appliance positioning

- ▶ Ensure the appliance is mounted onto a level, fixed rigid surface capable of supporting the appliance weight.
- ▶ Ensure all aspects of the installation are considered when positioning the appliance, flue run and discharge, condensate disposal, PRV discharge etc.

**WARNING:** Damage to property!  
Damage caused by drilling into pipes, electrical cables, damp proof course or other hazards.

- ▶ Before drilling ensure that there are no obstructions or other hazards.

**NOTICE:** Damage to appliance!  
Residue, metal shavings, and contaminants in the system pipe work can damage the appliance.

- ▶ Flushing the system pipe work thoroughly and completely to remove all residue.
- ▶ Follow the instructions with respect to cleaning primary systems.

**i** Flue outlet position

- ▶ Ensure all horizontal flue sections rise away from the appliance by 52mm per metre to ensure that condensate flows back into the appliance for safe discharge via the condensate waste pipe.

## 5.3 Wall mounting template & flue opening

### SAFETY:

All relevant safety precautions must be undertaken. Protective clothing, footwear, gloves and safety goggles must be worn as appropriate.

### FIXING THE MOUNTING FRAME:

- ▶ The appliance template shows the relative positions of the flue and the top and bottom fixing of the mounting frame.
1. Fix the template to the wall in the desired position.
  2. Drill four holes for the wall mounting frame through the template.  
Drill two holes for the bottom fixing screws.

**i** The template has been sized to allow for minimum clearances of 5mm sides, 200mm base and 30mm above a 100mm diameter flue elbow.

### REAR FLUE OUTLET

- ▶ The drawing opposite shows the appliance template with the flue centre lines of both the 100mm and 125mm flue systems.
3. Mark centre line of flue to be used (3); the external diameter of the hole can also be marked if required.
  - ▶ If a 100mm diameter flue is to be used, a 125mm diameter hole is required. However, if using the weather sealing collar by pushing it through from inside the property, then a 150 mm diameter hole is required to accommodate this.
  - ▶ The flue turret of the 100mm flue has an in-built 3° angle.
  - ▶ If extensions are to be added then the complete flue must rise at an angle of 3°.
  - ▶ The 125mm diameter flue system will require the flue to rise at an angle of 3°.
  - ▶ Drill hole using a core drill or similar.

### SIDE OUTLET:

4. Mark from the centre line of the wall template to the wall which the flue will pass through (4).
- ▶ Allow for a rise of 52mm per metre length of flue, to give a 3° angle.
- ▶ Clear any debris from the site.

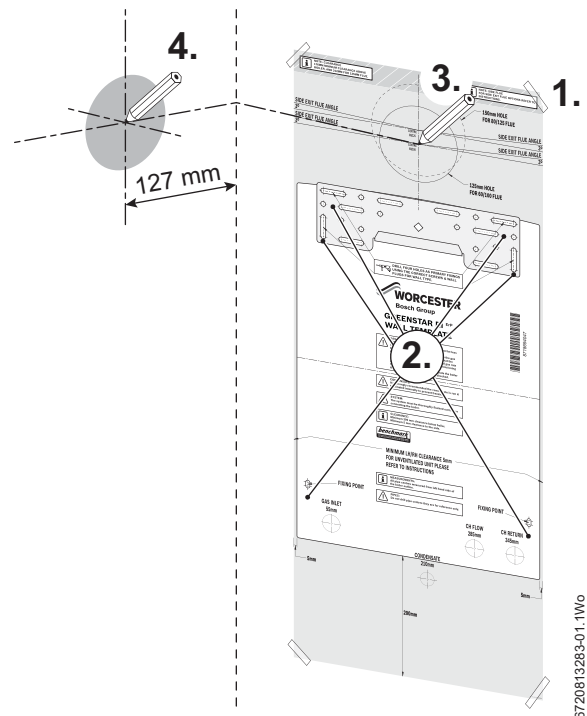
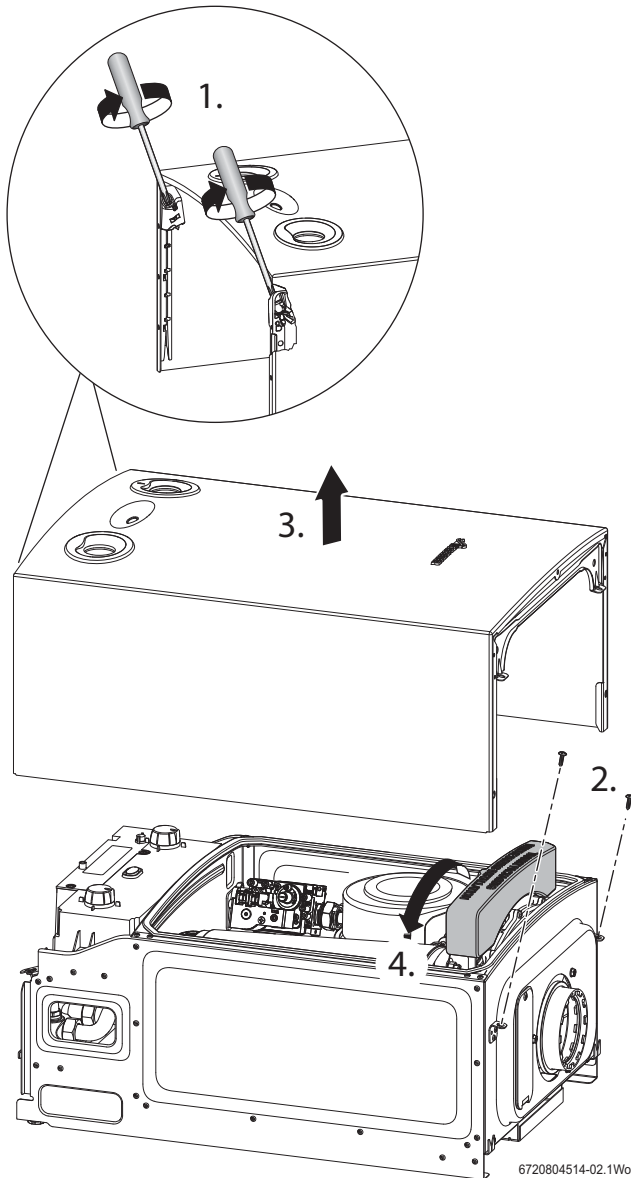

Fig. 26 Marking the flue position

### 5.4 OUTER CASE REMOVAL

1. Undo the two captive screws securing appliance casing at the bottom of the appliance.
2. Undo the two screws securing appliance casing at the top of the appliance.
3. Pull case upwards.
4. Remove the transit packing piece from appliance and discard.

With the outer case removed the appliance is suitable for a one man lift (<25kg).



6720804514-02.1W6

Fig. 27 Case removal

### 5.5 APPLIANCE CONNECTION



**CAUTION:**

- ▶ ISOLATE THE MAINS GAS SUPPLY BEFORE STARTING ANY WORK AND OBSERVE ALL RELEVANT SAFETY PRECAUTIONS.



**WARNING:**

- ▶ Caps fitted to pipes must be removed before hanging the appliance

**GAS AND WATER CONNECTIONS:**

- ▶ Remove wall mounting template and secure the wall mounting frame to the wall with the appropriate fittings for the appliance weight and wall type.
- ▶ If there is greater than 600mm clearance below the appliance it is possible to fit the flow and return pipes, supplied, with the appliance installed on the wall.
- ▶ If clearance is less than 600mm below the appliance it may be necessary to fit the flow and return pipes before hanging the appliance.



The copper pipes supplied with the appliance are not to be used for the gas supply. These copper pipes are for water only.



**NOTICE:**

- ▶ Lift the appliance using the handling holes at either side of the frame. Do not lift the appliance by the air gas manifold or control box.

System pipes may be run vertically up behind the appliance or below it.



**NOTICE:**

- ▶ If pipes require reducing in length this is best done before they are fitted to the appliance.

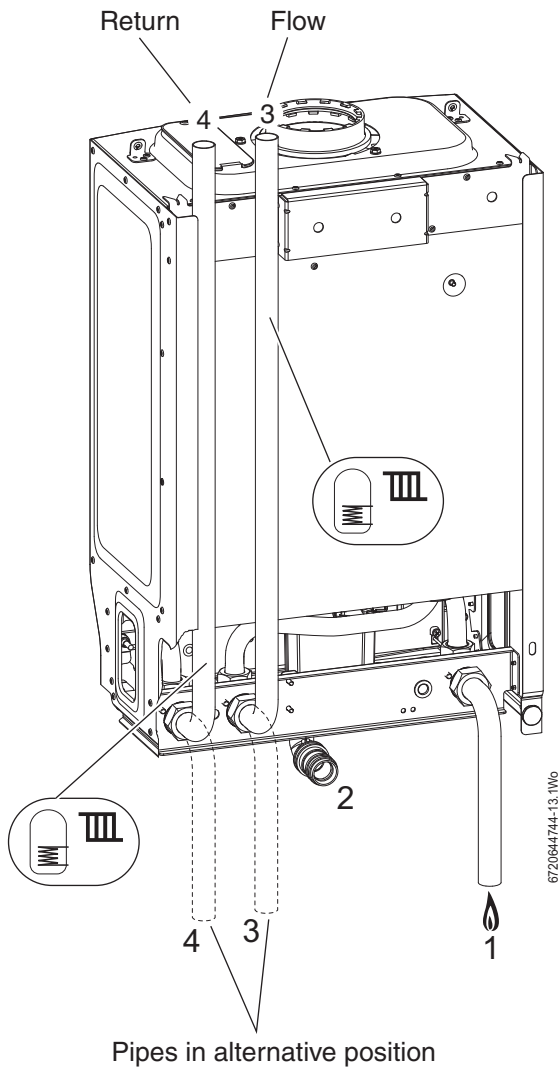

Fig. 28 Plumbing manifold

- [1] Gas inlet (22mm)
- [2] Condensate
- [3] Flow (22mm)
- [4] Return (22mm)

- ▶ Lift the appliance onto the wall plate.
- ▶ Level vertically using the feet (1) at the bottom rear of the appliance casing.
- ▶ Fit retaining screws through the holes (2) in the appliance frame to secure the appliance.
- ▶ Make connections to the heating system pipes.

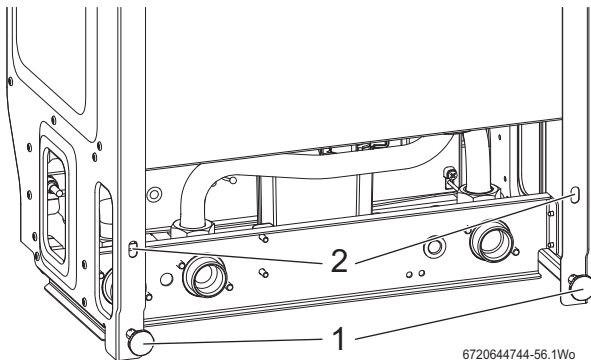

Fig. 29 Levelling and securing detail

### 5.5.1 CONDENSATE CONNECTION

Never terminate or discharge into any open source, including: sink, bath, shower, bidet, toilet etc.



**NOTICE:** Condensate disposal

- ▶ Follow the recommendations given in section 4.3 “Condensate pipe work” for all condensate disposal installation.
- ▶ Ensure that the condensate pipe work falls continuously at least 50mm per metre towards the outlet.
- ▶ \* Do not use solvents, adhesive or lubricant when pushing the pipe onto the rubber connector.

Figure 31 gives the pipe work dimensions with respect to the mounting surface.



When using the pre-formed water pipes provided with the appliance, offset the water pipes connecting to them by 5mm to enable pipe clamps to be fitted.

A sealing washer (1) and 22mm adaptor (2) are supplied in the fitting pack

1. Fit washer (1) inside the plastic nut and attach firmly to the connection on the syphon.
2. Connect the condensate disposal pipe work to the elbow (2), refer to figure 31 and insert the condensate pipe 25mm into the elbow.

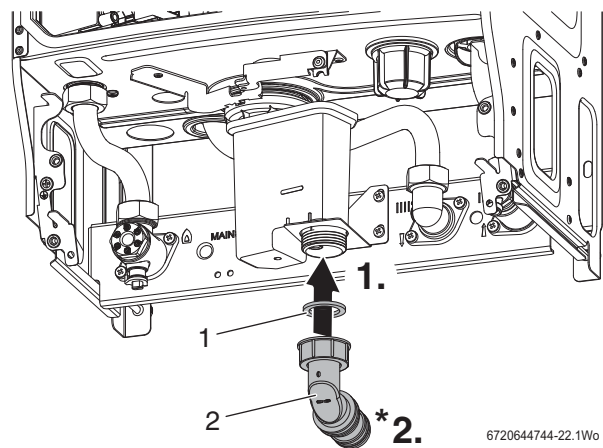

Fig. 30 Condensate connections

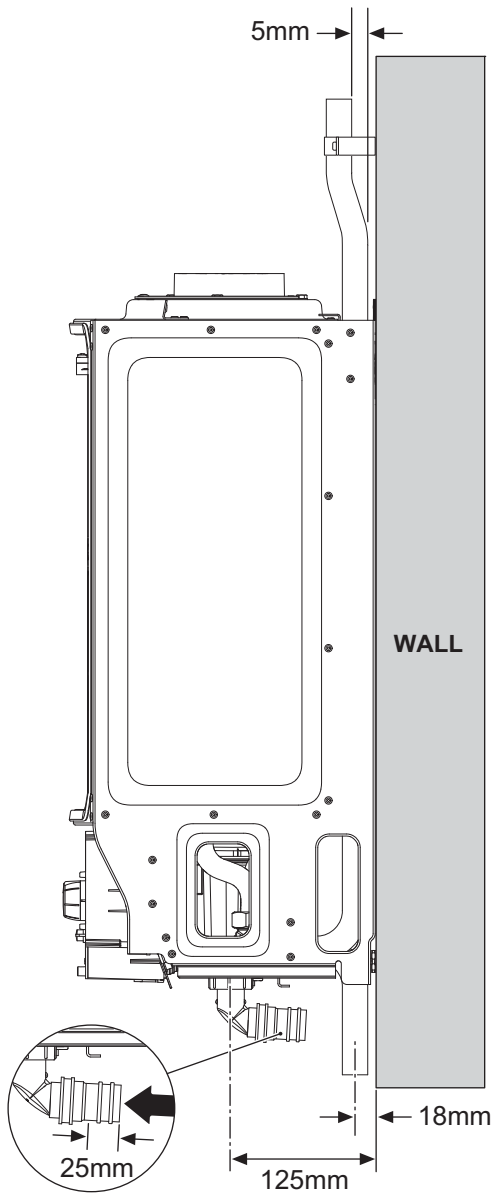

Fig. 31 Pipe work dimensions

### 5.6 Flue turret/adaptor installation

The flue turret/adaptor for the appliance is secured using three retaining screws (figure 32, item [1]) which come in position on the appliance.



To ease assembly of flue components, apply silicone lubricant to sealing surfaces. Refer to the manual supplied with the flue kit for complete installation instructions. For plume management effective lengths and the effective flue lengths, refer to details in section 4.7.

Refer to figures 32 & 33.

- ▶ Remove the three inner flue tube retaining screws [1]. The inner tube will be held in place in the appliance.
- ▶ Check the appliance flue seal [2] is correctly seated and apply silicone grease.

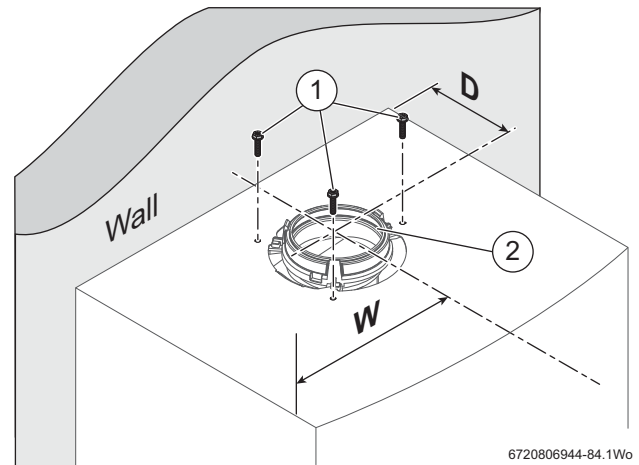

Fig. 32 Flue turret centre

[D] 127mm  
[W] 195mm

- ▶ Align the flue turret/vertical adaptor to the appliance flue outlet with flat facing [3] to the rear of the appliance. The flue turret/adaptor should be pushed straight down, on to the appliance.
- ▶ The three inner flue tube retaining screws [1] are, re-used for the flue turret and replacement retaining screws [4] supplied with the adaptor kit are used to secure turret/adaptor to the appliance.

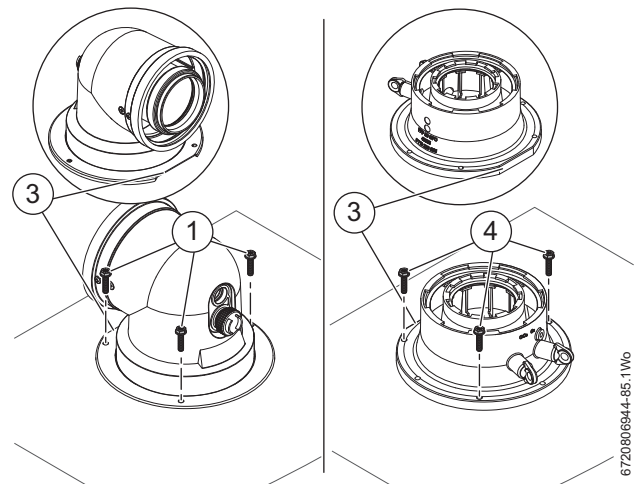

Fig. 33 Flue turret/adaptor connection

#### Additional notes and reminders:

- Ensure that all cut lengths are square and free from burrs.
- Ensure that the flue and seals are not damaged.
- The flue is sealed when assembled correctly, the components are pushed fully home and secured.
- The flue is set at an angle of 3° or 52mm per metre length.
- Support the flue at approximately one metre intervals and at a change of direction, use suitable brackets and fittings (flue bracket 100mm part number: 7 716 191 177, flue brackets 100mm x 6 part number: 7 716 191 178, flue bracket 125mm part number: 7 716 191 179)

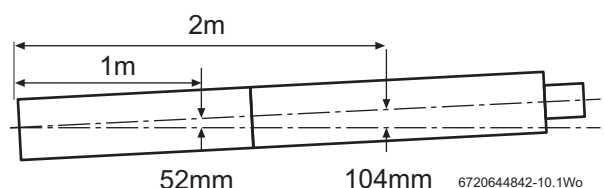

Fig. 34 Slope for condensate disposal

**5.7 ELECTRICAL CONNECTIONS**



**CAUTION:** Isolate the mains electrical supply before starting any work and observe all relevant safety precautions.



The appliance is already wired with a mains supply cable. A spare strain relief block is supplied in case the pre-wired cable is replaced.1

- ▶ The mains supply to the appliance and system wiring centre must be common, and through either a fused double pole isolator or a fused three pin plug and unswitched socket.
- ▶ The isolator/socket, where practicable, should be situated next to the appliance.
- ▶ The isolator must have a contact separation of 3mm minimum in both poles.
- ▶ Any system connected to the appliance must not have a separate electrical supply.
- ▶ External fuse rating 3A.

**ACCESS TO ELECTRICAL CONTROL PANEL:**

- ▶ Remove appliance casing to access control panel.
  1. Unscrew the three screws in the control panel.
  2. Remove the connections cover.
- ▶ Unclip cable clamp.
- ▶ Cut off the tapered cable entry to fit cable diameter required.
- ▶ Turn cable retaining screw anti-clockwise
- ▶ Run cable through the hole in the main crossbar marked "mains cable" and through the cable clamp, ensure there is ample cable to reach the connectors.
- ▶ Turn cable clamping screw clockwise to secure cable and replace clamp into control panel.
- 3. **Mains power 230v connection (ST1):**
  - Separate wires from cable end and strip to 6mm
  - Connect LIVE wire to terminal (L)
  - Connect NEUTRAL wire to the terminal (N)
  - Connect EARTH wire to earth bracket
- 4. **External Pump (ST2): Max power 90 W**
  - Connect NEUTRAL wire to terminal (Np)
  - Connect LIVE wire to terminal (Lp)
  - Connect EARTH wire to earth bracket
- 5. **Appliance Demand (from external wiring centre) (ST2):**
  - Connect SWITCHED LIVE wire to terminal (LR).



**NOTICE:** Mains supply and system pump

- ▶ The appliance must have a permanent 230V power supply to the PCB connections L, N & E.
- ▶ The system pump must be powered from the pump connections on the PCB Lp, Np and the earth bracket.

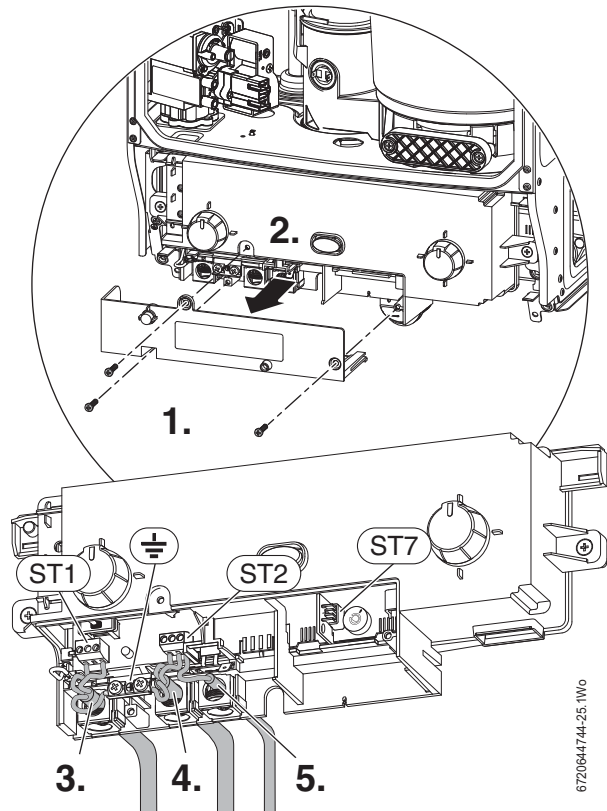





Fig. 35 Wiring detail

| Installer connections   |       |   |
|---|-------|---|
| Connection  |       | Function  |
|  | ST1   | 230V supply to the appliance<br>• Live input (L)<br>• Neutral input (N)   |
|  | ST2   | External pump supply connections and Switched live (Live Return) to the appliance<br>• Pump Live (LP)<br>• Pump Neutral (NP)<br>• Demand input (LR) |
|  | Earth | • Earth connection, appliance 230V supply<br>• Earth connection, external pump supply   |

**NEW COMPLETE SYSTEM INSTALLATIONS**

If a new complete heating system is installed in a new build property or it is a first time installation in an existing property, the heating systems must conform to current building regulations Part L 1a.

The exception to this are single storey, open plan dwellings where the living area is more than 70% of the total usable floor area. Then this type of dwelling can be controlled as one zone.

An alternative would be individual electronically controlled TRVs.

For dwellings with a floor area over 150m<sup>2</sup>, separate time and temperature control for each zone is required. All radiators must have TRVs fitted in all rooms except bathrooms and rooms with thermostats.

**EXISTING INSTALLATIONS**

For appliance replacements on an existing system, it is not necessary to zone the upstairs and downstairs differently, compliance with the zone requirements can be achieved by a single room thermostat or programmable room thermostat.

While the system is drained down, TRVs must be fitted to all rooms except the bathrooms and the room with the thermostat.

## EXTERNAL WIRING CENTRE

System components wired into terminal strip in accordance with system manufacturers instructions.

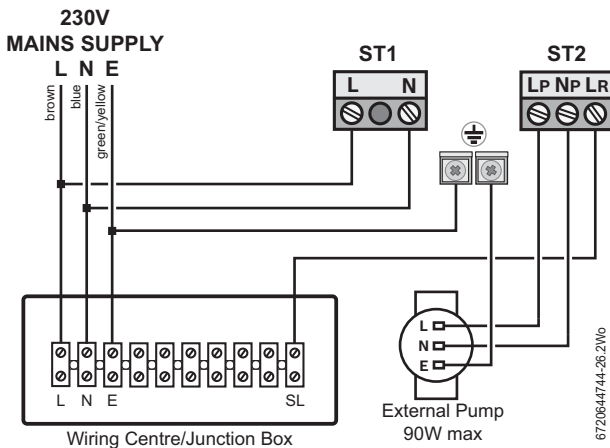

Fig. 36 External wiring centre

[⏚] Earth connection

### Appliance connection - ST1:

- [L] Permanent Live feed to the appliance
- [N] Permanent Neutral feed to the appliance

### Appliance connection - ST2:

- [LP] External pump Live feed from the appliance
- [NP] External pump Neutral feed from the appliance
- [LR] Demand (Live Return), input from wiring centre/junction box to call the appliance to fire for heating/hot water

### Wiring centre/junction box connection :

- [L] Permanent Live feed to the wiring centre/junction box
- [N] Permanent Neutral feed to the wiring centre/junction box
- [E] Earth connection on the wiring centre/junction box
- [SL] Demand (Switched Live), output to the appliance to fire for heating/hot water

Refit electric control panel covers:

- ▶ Refit panel and secure with screws.

## 6 COMMISSIONING

### 6.1 PRE-COMMISSIONING CHECKS



#### WARNING: ELECTRIC SHOCK

- ▶ ISOLATE THE MAINS SUPPLIES BEFORE STARTING ANY WORK AND OBSERVE ALL RELEVANT SAFETY PRECAUTIONS

- ▶ Check that the gas service pipe and water pipes are connected to the correct position on the manifold.

1. Gas inlet (22mm)
2. Flow (22mm)
3. Return (22mm)

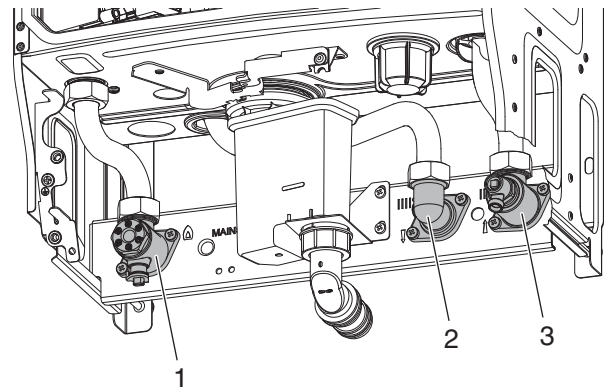

Fig. 37

- ▶ Check the gas type specified on the identification plate (1) matches that of the gas supply.

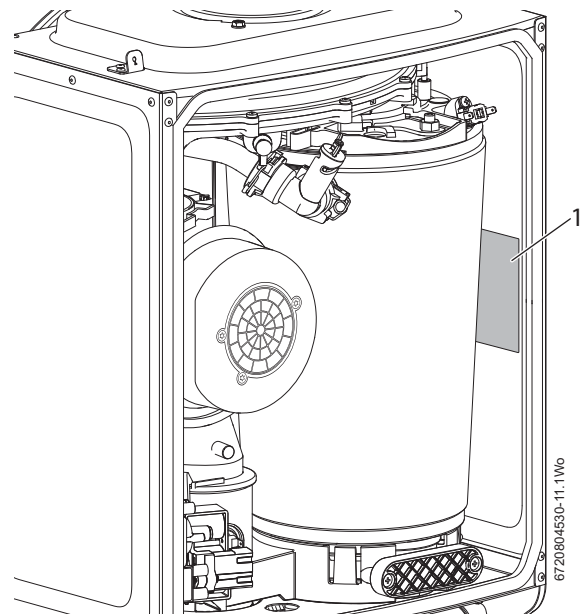



Fig. 38 Data plate location

- ▶ Turn on the main gas supply, check the gas pipe work, connections and rectify any leaks.

 **NOTICE:** Do not use solvents, adhesive or lubricant when pushing the pipe onto the rubber connector.

- ▶ Check that the condensate pipe has been connected to the syphon.
- ▶ Ensure that the condensate pipe has been inserted at least 25mm into the elbow

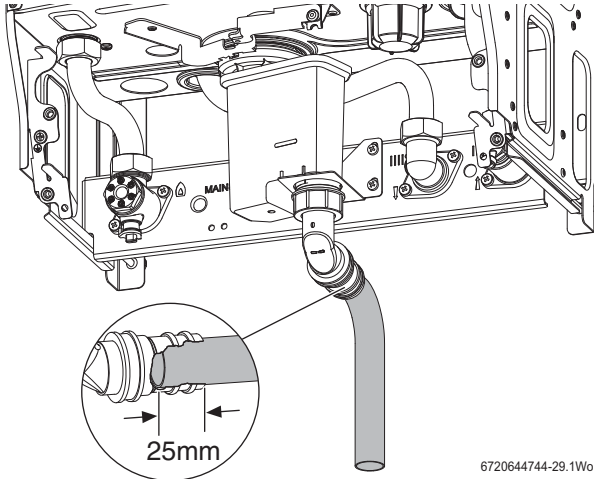



Fig. 39 Condensate connection

 If the appliance is not to be commissioned immediately then, after successfully completing all of the checks and any rectification work, shut off the gas and water supply and electrically isolate the appliance.

**6.2 FILLING THE SYSTEM**

Open vented systems:

- ▶ Ensure all system and appliance drain points are closed.
- ▶ Open all radiator valves.
- ▶ Turn on the water supply to the system header tank and allow the system to fill.

Sealed systems:

- ▶ Fill the system via a WRAS approved filling loop to 1 bar then turn the valve anti-clockwise to close.

Opened vented and sealed systems:

- ▶ Vent (1) any air from the appliance heat exchanger using a suitable container to collect any water. Ensure tube outlet (2) is directed away from the fan or any other electrical component to prevent any water damage. Also place a suitable cover over the fan to prevent any spillage of water on to electrical connections. Ensure the cover is removed after venting.

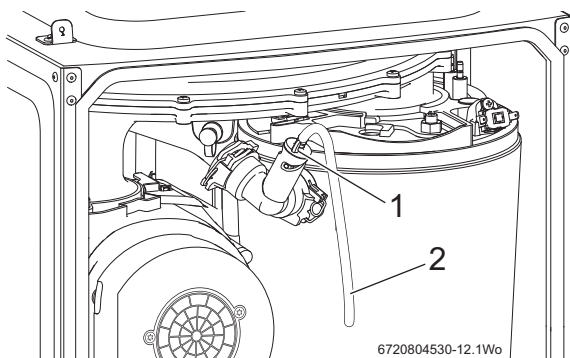



Fig. 40 Venting

- ▶ Vent all radiators and the primary side of the hot water cylinder, tighten when completed and check the system and correct any leaks.
- Sealed systems only:
- ▶ If required increase system pressure back to 1 bar.
  - ▶ Isolate and remove filling loop connection to system.

**6.3 WATER TREATMENT**

 **NOTICE:**

- ▶ ARTIFICIALLY SOFTENED WATER MUST NOT BE USED TO FILL THE CENTRAL HEATING SYSTEM.

It is possible to have an ion exchange water softener fitted to the cold water system of the property. However, the appliance requires an untreated cold water connection taken from the mains supply, before the water softener, to the primary water filling point of the heating system.

Alternatively there are water softening/treatment devices that do not adjust or alter the pH levels of the water. With these devices it may not be necessary to provide an untreated water by-pass to the primary water filling point of the heat system.

**ENSURE THAT THE SYSTEM HAS BEEN CLEANED AS ON PAGE 30 OF THESE INSTRUCTIONS.**

**FLUSHING (Central Heating):**

- ▶ Switch off the appliance.
- ▶ Open all drain cocks and drain the system while the appliance is hot.
- ▶ Close drain cocks and add a suitable flushing agent at the correct strength for the system condition in accordance with the manufacturer's instructions.
- ▶ Run the appliance/system at normal operating temperature for the time stated by the manufacturer of the flushing agent.
- ▶ Drain and thoroughly flush the system to remove the flushing agent and debris.

**INHIBITOR (Central Heating):**

- ▶ Check drain cocks are closed and all radiator valves are open before adding a suitable inhibitor compatible with aluminium (or combined inhibitor/anti-freeze if the system is exposed to freezing conditions) to the heating system water in accordance with the manufacturers instructions.

 The pH value of the system water must be less than 8 or the appliance guarantee will be invalidated.

- ▶ Fill system as described in section 6.2.
- ▶ Set all controls to maximum.
- ▶ Record the date when the inhibitor was added to the system on the guarantee card.

 **NOTICE:**

- ▶ The concentration of inhibitor in the system should be checked every 12 months or sooner if system content is lost.
- ▶ Normally the addition of sealing agents to the system water is not permitted as this can cause problems with deposits left in the heat exchanger.
- ▶ In cases where all attempts to find a micro leak have failed, Worcester, Bosch Group supports the use of Fernox F4 leak sealer.

**WATER TREATMENT PRODUCTS**

Suitable water treatment products can be obtained from the following manufacturers:

|          |   |
|----------|---|
| ADEY     | 01242 546717<br>www.adey.com                |
| FERNOX   | 0870 601 5000<br>www.fernox.com             |
| SENTINEL | 0800 389 4670<br>www.sentinel-solutions.net |

Table 31

**6.4 STARTING THE APPLIANCE**

**CAUTION: RUNNING THE APPLIANCE**

- ▶ Never run the appliance when the appliance/system is empty or partially filled.

**6.4.1 APPLIANCE CONTROLS**

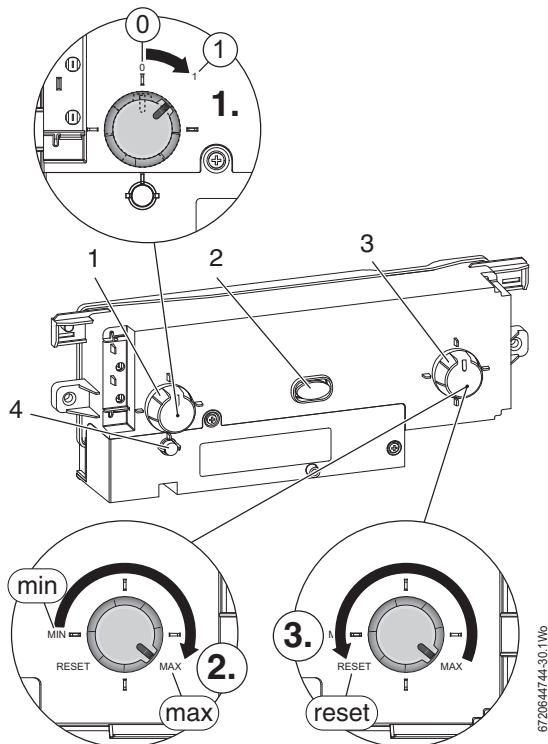

Fig. 41 Appliance controls

Switching the appliance ON/OFF:

- ▶ Turn on mains power, the power ON indicator (2) illuminates BLUE.
- ▶ Turn on any external controls
- ▶ Set the thermostatic radiator controls to maximum temperature
- ▶ Set the clock/programmer to continuously ON and the room thermostat to maximum temperature

1. Turn Power ON/OFF knob (1) from 0 (OFF position) to I (ON position), after two seconds the Power ON indicator (2) illuminates.

|   |                                     |
|---|-------------------------------------|
| 1 | Power ON/OFF knob                   |
| 2 | Power ON and fault indicator (Blue) |
| 3 | Central heating temperature control |
| 4 | Burner indicator (Green)            |

Table 32 Control panel legend

2. Turn the appliance CH temperature control (3) to maximum. The burner on indicator (4) illuminates GREEN when the burner has lit.
- ▶ If the appliance fails to light and the appliance goes to flame lock-out, the BLUE power indicator (2) will flash.



**NOTICE: RESET**

- ▶ Do not press the blue power indicator to reset the appliance.

3. To reset the lockout turn the appliance thermostat control to minimum, then passed minimum where the control knob will click at reset position, wait 5 seconds then turn to maximum. The appliance will be reset.

**6.5 COMMISSIONING**

Having checked:

- ▶ That the appliance has been installed in accordance with the installation instructions.
- ▶ The integrity of the flue system and flue seals, as described in section 7.3 of this manual.
- ▶ The integrity of the appliance combustion circuit and relevant seals.

**6.5.1 CHECKING THE GAS INLET PRESSURE**

The inlet pressure to the appliance must be checked using the following procedure:

**MEASURING THE INLET PRESSURE**

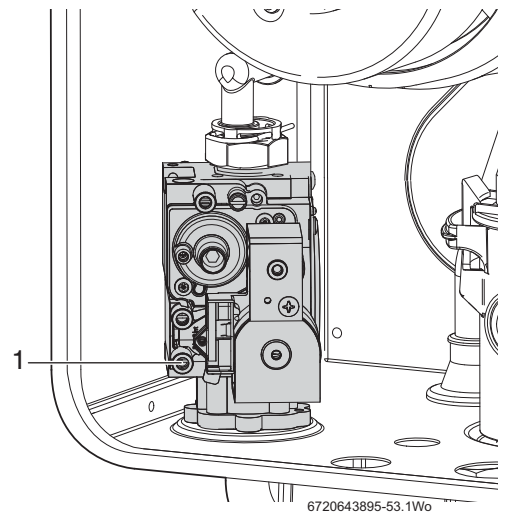

Fig. 42 Inlet pressure test point

- ▶ Close gas isolation valve.
- ▶ Slacken the screw in the inlet pressure test point (1) and connect a manometer.
- ▶ Open gas isolation valve.
- ▶ Measure the pressure with the appliance running at maximum.
  - Refer to section 7.4 to set the appliance to maximum output.
  - The appliance will stay at maximum for 15 minutes.
  - Return the appliance to normal after the checks.
- ▶ Check the gas supply working pressure at the gas valve conforms to values shown in Fig. 43 or Fig. 44 .

**GAS PRESSURE WITHIN THE SYSTEM**

Refer to the figures below for natural gas or L.P.G gas pressures.

The pressure at the appliance must not be less than the pressure read at the meter minus:

- 1mbar for Natural Gas
- 2.5mbar for LPG

The pressure drop from the meter to the gas valve must not be more than:

- 2.5mbar for Natural Gas
- 4mbar for LPG

If the pressure drops are greater than shown below, then this would indicate a problem with the pipe work or connections within the system.

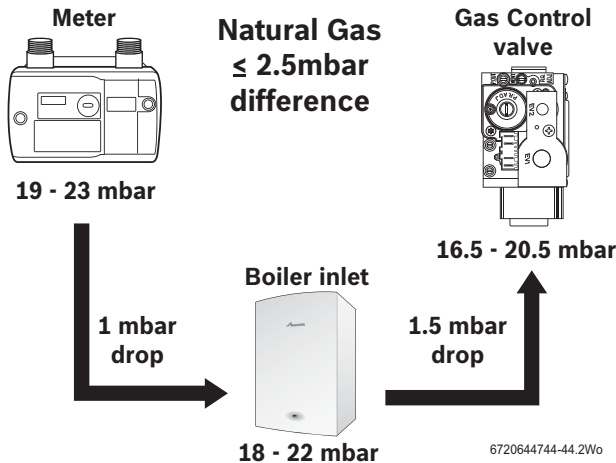

Fig. 43 Natural gas pressures

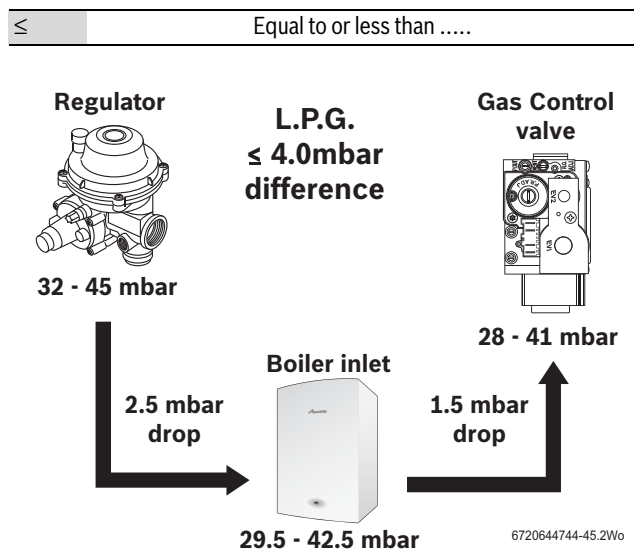

Fig. 44 LPG pressures

**NOTICE:**  
Do not continue commissioning until the correct gas pressure is achieved.

**6.5.2 Checking the gas rate**

- ▶ The gas rate should be measured at the gas meter after 10 minutes operation at maximum.  
See technical data section at the front of this manual.
- ▶ Where a gas meter is not available (e.g. LPG) the CO/CO<sub>2</sub> must be checked to the units shown in the setting of the air/gas ratio, refer to section 7.6.
- ▶ If pressure and gas rate are satisfactory press the service button and the appliance will return to normal operation.
  - If left in the service mode the control will return to normal operation after 15 minutes.
- ▶ Close the gas isolation valve.
- ▶ Remove the manometer.
- ▶ Re-seal the screw in the gas inlet pressure test point.
- ▶ Open the gas isolation valve.
- ▶ Ensure that there are no gas leaks.
- ▶ Replace the outer case.

**6.6 CO AND COMBUSTION CHECKS**

The following combustion and flue integrity checks are mandatory from April 2014 and these values must be recorded on the Benchmark check list, at the back of this manual.

Once the gas rate and pressure have been confirmed as acceptable then the CO and combustion checks can be undertaken.

The flow chart is given for guidance, the details of the checks are given in the following sections:

- Checking flue integrity, refer to section 7.3, page 45
- Flue gas analysis, refer to section 7.5, page 46

**NOTICE: BEFORE CO AND COMBUSTION CHECKS:**

- ▶ Refer to section 6.5.1 and 6.5.2 to verify gas type, gas inlet pressure, and gas rate.  
Visually check the integrity of the whole flue system and confirm that all the components are correctly assembled, fixed and supported.
- ▶ The flue gas analyser must be the correct type as specified in BS 7967. Before use the analyser must have been calibrated as specified by the manufacturer.  
The installer must be competent in the use of the analyser.  
Check and zero the analyser in fresh air as specified by the manufacturer.
- ▶ The gas valve is factory set and must not be adjusted during commissioning if found to be out of tolerance, please contact the Worcester, Bosch Group help line 0330 123 3366.

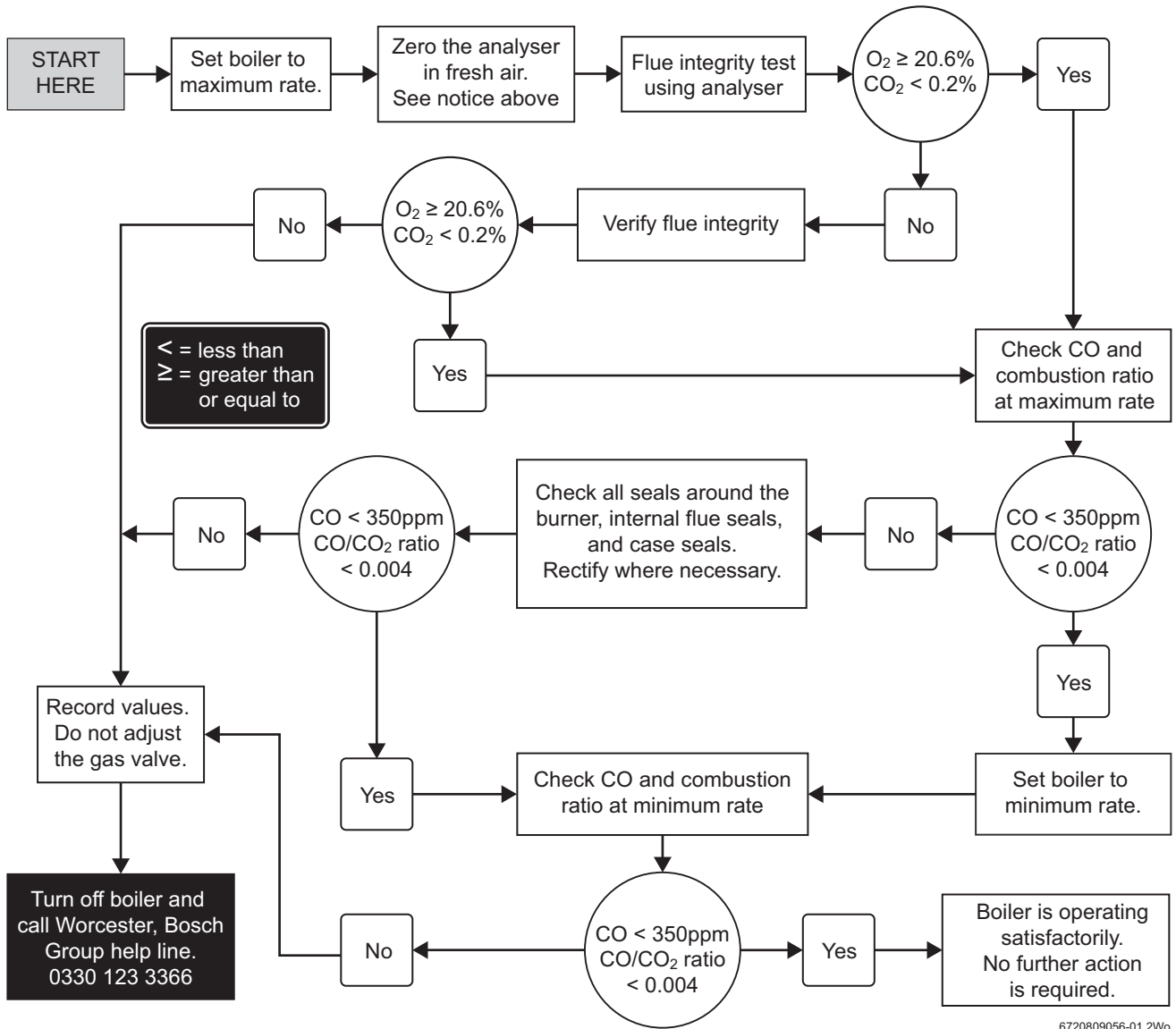

6720809056-01.2Wo

Fig. 45 Combustion check flow chart

## 6.7 FINISHING COMMISSIONING

### 6.7.1 REPLACE THE OUTER CASE:

Replace outer casing making sure that the securing points are properly located.

1. Replace top two screws.
2. Re-tighten bottom two screws.

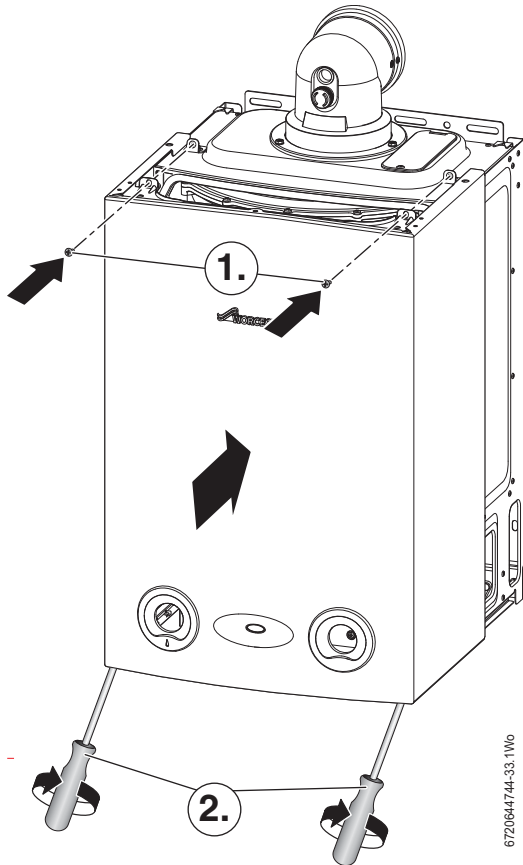

Fig. 46 Replacing outer case

### 6.7.2 INSTALL THE BOTTOM PANEL

The cut out in the bottom panel fits easily over the syphon elbow and outlet, however care should be taken not to disturb any sealed components.

1. Hook the lip at the back of the bottom panel over the angled edge at the base of the connections manifold.
2. Push up into position.
3. Secure in position the screw provided.

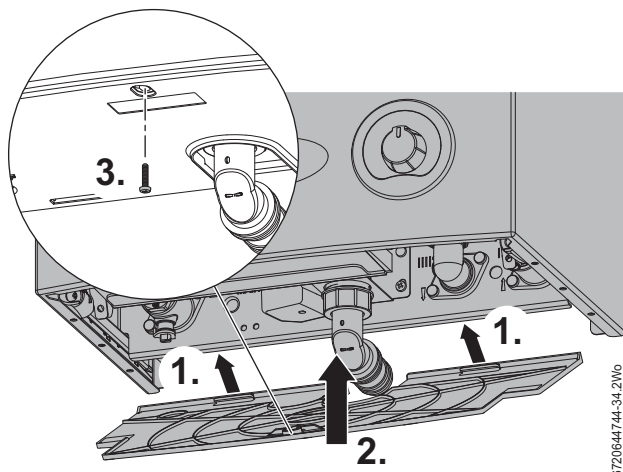

Fig. 47 Bottom panel

### 6.7.3 HAND OVER

- ▶ Complete the Benchmark Gas Boiler Commissioning Checklist.
- ▶ Set up the appliance controls and show the customer how to operate all the control unit/s for central heating operation.
  - Also show where in the appliance/controls documentation where this information can be found.
- ▶ Where applicable, instruct the customer on:
  - the need to occasionally re-pressurise the appliance and the pressure expected at the pressure gauge.
  - location of the filling loop and system pressure gauge.
  - the use of the filling loop and how to re-pressurise the system.
  - where to find and store the filling loop key, if necessary.
  - how to set the TRVs.
  - how to reset the appliance.
- ▶ Show the customer the fault finding information in the User instructions.
- ▶ Show the customer where the serial number/appliance information is located, they will need this information if they call in with a problem (Benchmark Commissioning checklist contains all relevant appliance information).
- ▶ Give the customer details of how to contact the installer/ gas emergency numbers.
- ▶ Show the customer how to safely isolate the appliance.
- ▶ Advise the customer where they can find information on the Worcester, Bosch Group website, [www.worcester-bosch.co.uk](http://www.worcester-bosch.co.uk).
- ▶ Advise the customer that outside temperatures will affect the output of the appliance, especially the DHW.
- ▶ Ensure that all documentation, is left with the appliance or homeowner.
  - Appliance documentation.
  - Controls documentation.
  - Any other equipment documentation that is connected to the appliance or system.
- ▶ Appliance not in use
  - If the appliance is not going to be used immediately and may be exposed to freezing conditions, advise the customer of the precautions necessary to prevent damage to the appliance, system and building.
  - If the appliance is unused and exposed to freezing conditions, shut off all the mains supplies and drain the system and appliance, label accordingly.
- ▶ Show the customer the location of the condensate pipe run in unheated or external areas that may be at risk of freezing during prolonged cold spells.
- ▶ **User recommendation:** Arrange an inspection/maintenance contract with an approved heating contractor.

#### 6.7.4 Appliance guarantee

This appliance has a guarantee against faulty materials or workmanship for a period from the date of installation subject to the following terms and conditions:

- The guarantee period for your product/component will vary depending on its type and the accreditation of your installer. To confirm the guarantee period applicable to your product, please visit our website [www.worcester-bosch.co.uk](http://www.worcester-bosch.co.uk).
- The guarantee must be registered within 30 days of installation.
- The householder may be asked to prove the date of installation and that the appliance was correctly commissioned. This should be documented as a part of the Commissioning Checklist.
- The product must be correctly installed and commissioned in accordance with the Installation instruction for your product and meet the requirements of the Benchmark initiative if applicable.
- The product must be maintained, inspected/serviced in accordance with the manufacturer's product instructions by a Bosch Thermotechnology Ltd or other competent Engineer. Proof of inspection/servicing may be required to validate a guarantee.
- During the period of this guarantee any components of the appliance that are proven to be faulty or defective in manufacture will be exchanged or repaired free of charge if repaired directly by Bosch Thermotechnology Ltd.
- Invoices for attendance and repair of this appliance by third parties will not be accepted for payment by Bosch Thermotechnology Ltd.
- That any product or part thereof returned for servicing under the guarantee must be accompanied by a claim stating the Model, Serial Number, Date of Installation.
- That Bosch Thermotechnology Ltd will not accept responsibility for damage caused by faulty installation, neglect, misuse or accidental damage or the nonobservance of the instructions contained in the Installation and Users Instructions leaflets.
- The appliance has been used only for the normal domestic purposes for which it was designed.
- That this guarantee applies only to equipment purchased and used in the United Kingdom of Great Britain and Northern Ireland, the Republic of Ireland, the Isle of Man or the Channel Islands.

**For full terms and conditions, please visit:**

[www.worcester-bosch.co.uk/guarantee-terms-and-conditions](http://www.worcester-bosch.co.uk/guarantee-terms-and-conditions)

**Guarantee registration**

Your Greenstar appliance carries a guarantee against faulty material or manufacture subject to Terms and Conditions.

Guarantee Registration can be completed:

- On-line
  - You can register on our website:  
[www.worcester-bosch.co.uk/guarantee](http://www.worcester-bosch.co.uk/guarantee)
- By phone
  - You can register by ringing 0330 123 2552
- By post
  - Please send your completed form to:  
Worcester, Bosch Group, Cotswold Way, Warndon, Worcester, WR4 9SW.

To read the full Terms & Conditions please visit us on-line at [www.worcester-bosch.co.uk/guarantee](http://www.worcester-bosch.co.uk/guarantee).

Your statutory rights are not affected by the manufacturer's guarantee.

## 7 SERVICE AND SPARES

### 7.1 INSPECTION AND SERVICE



**CAUTION:** TURN OFF THE GAS SUPPLY AND ISOLATE THE MAINS SUPPLIES BEFORE STARTING ANY WORK AND OBSERVE ALL RELEVANT SAFETY PRECAUTIONS.



**NOTICE:** COMPONENTS.

- ▶ After replacement of any components always check for gas tightness where relevant and carry out functional checks as described in Commissioning. Damaged O-rings or gaskets must be replaced.



**NOTICE:** Service work

- ▶ Service work must be carried out by a competent engineer, such as Gas Safe registered personnel!



**NOTICE:** FLUE GAS ANALYSER

- ▶ Service work must not be attempted if a flue gas analyser is not available.

- To ensure the continued efficient operation of the appliance it must be checked at regular intervals.
- The frequency of servicing will depend upon the particular installation conditions and usage however, an annual service is recommended.
- The extent of the service required by the appliance is determined by the operating condition of the appliance when tested by fully qualified engineers.
- The service interval record sheet at the rear of these instructions must be completed after each service.

**INSPECTION**

1. Check that the terminal and the terminal guard, if fitted, are clear and undamaged.
2. If the appliance is in a compartment or cupboard check that the specified service space around the appliance is clear.
3. Check all the joints and connections in the system and remake any that show signs of leakage.  
Refill and re-pressurise if applicable as described in Commissioning, section 6.2.
4. Operate the appliance and take note of any irregularities.  
Refer to Fault Finding on page 58 for rectification procedures.

**COMPONENT ACCESS**

Removing outer case

1. Undo and remove two screws securing appliance casing at the top of the appliance.
  2. Undo but do not remove the two screws securing appliance casing at the bottom of the appliance.
- Pull case forward and remove.

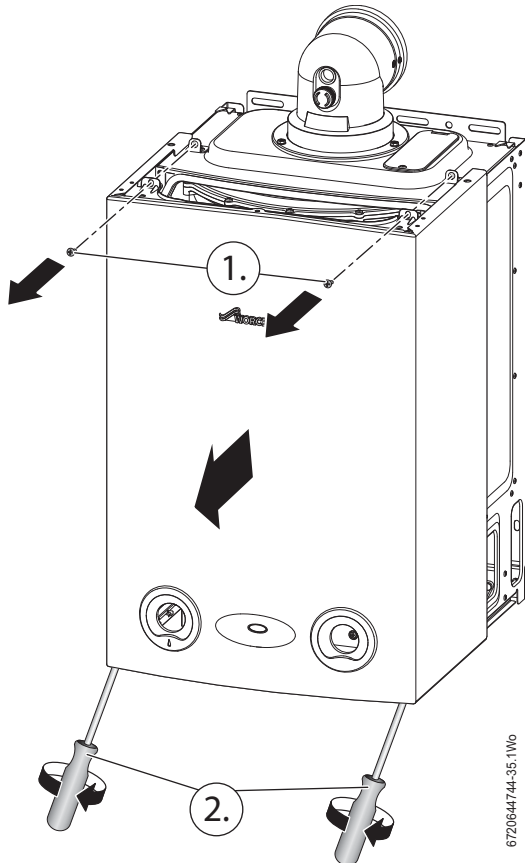

Fig. 48 Remove outer case

**LOWERING THE APPLIANCE CONTROLS TO THE SERVICE POSITION:**

1. Remove two screws securing the control.
2. Pull the control forward.
3. Lower the control to align the slots at the top of the control with the lugs on the appliance framework.
4. Hang control on two lugs on appliance framework.

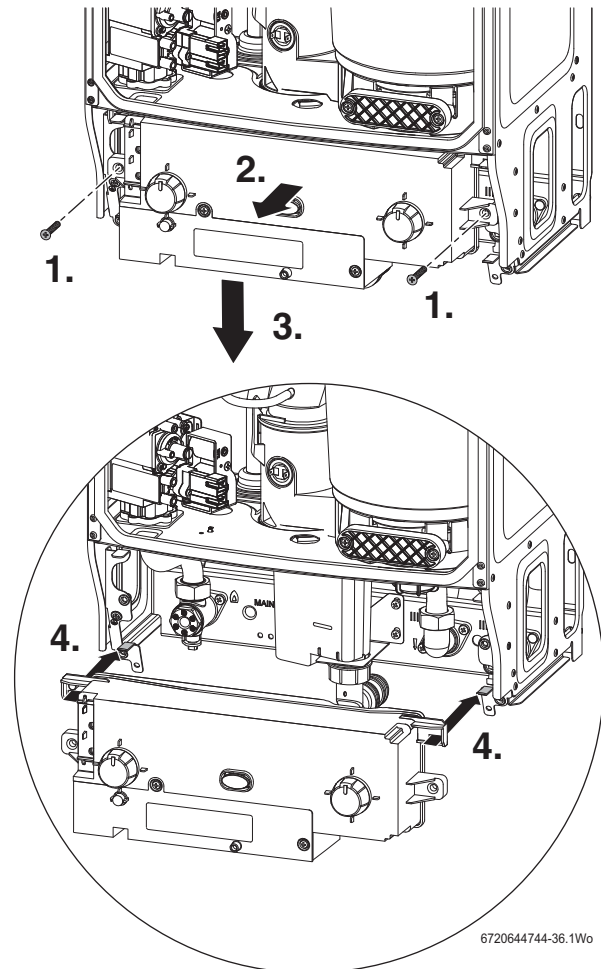

Fig. 49 Control panel into service position

**7.2 CHECKING GAS INLET PRESSURE**

Refer to section 6.5.1 for checking the gas inlet pressure

|  |   |
|--|---|
|  | <p><b>NOTICE:</b></p> <p>► Do not continue with the other checks if the correct gas inlet pressure can not be achieved.</p> |
|--|---|

### 7.3 CHECKING FLUE INTEGRITY

The integrity of the flue system and performance of the appliance can be checked via the flue turret sample points.

|                        |   |
|------------------------|---|
| Flue gas sample point  | 1 |
| Air inlet sample point | 2 |

Table 33 Key to figure 50

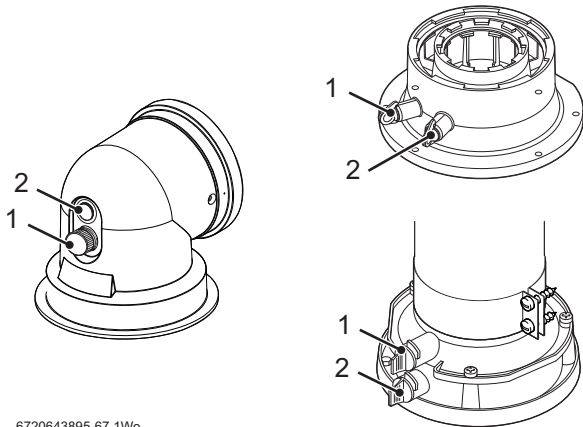

6720643895-67.1Wo

Fig. 50 Flue test points

- ▶ With the appliance case on and the appliance running at maximum.
- ▶ Insert the analyser probe into the air intake test point.
- ▶ Allow the readings to stabilise and check that:
  - O<sub>2</sub> is equal to, or greater than 20.6%
  - CO<sub>2</sub> is less than 0.2%
- ▶ If the readings are outside these limits then this indicates that there is a problem with the flue system or combustion circuit, e.g. missing or dislodged seals.

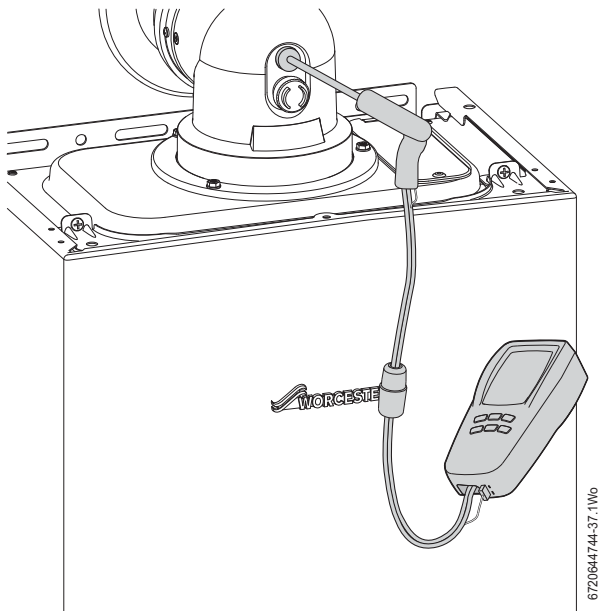

Fig. 51 Flue integrity test

### 7.4 FAN PRESSURE TEST



**This test is to** determine if the heat cell requires cleaning/attention.

#### SETTING THE APPLIANCE TO MAXIMUM

1. Remove the three screws retaining the control cover.
2. Remove the control cover.
3. Remove the plastic tool clipped inside the cover.
4. Insert the tool into the switch.
5. Using the tool set the mode switch to maximum output (MAX).

Ensure the appliance is powered up and there is a demand from the external controls.

The power indicator will flash and the appliance will stay in this mode for 15 minutes if no further change is made to the switch.

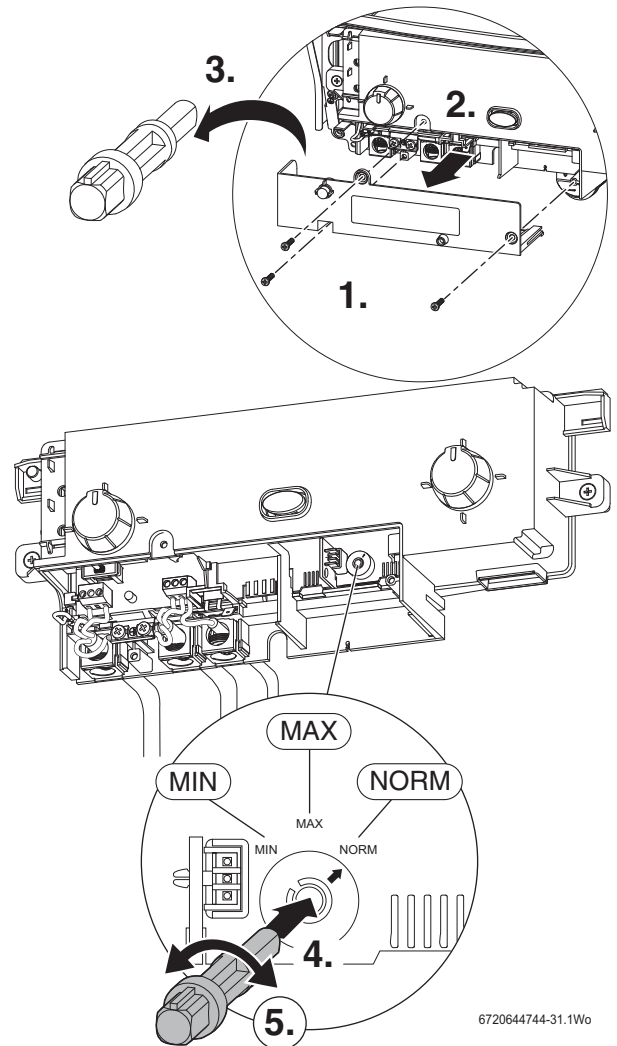

Fig. 52 Setting the appliance to maximum

**FAN PRESSURE TEST**

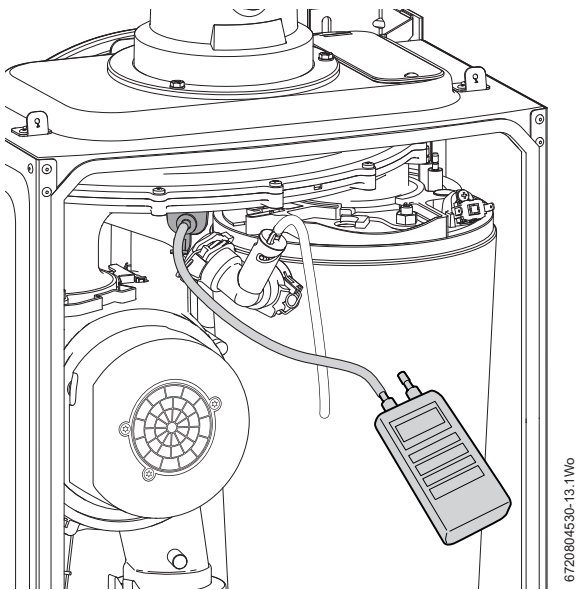

Fig. 53 Fan pressure test

- ▶ Remove the cover and connect a digital manometer to the fan pressure test point.
- ▶ The pressure will read negative, refer to the chart in figure 54.
- ▶ After measurement replace test point cover and return mode switch to normal.
- ▶ Replace the control cover.
- ▶ Replace outer case.

**NOTICE:**

The appliance must be run at maximum output for Fan Pressure test and the Flue Gas analysis.

**FAN PRESSURE TEST**



**NG Boilers**

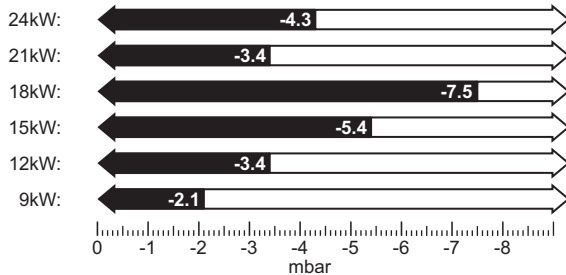

**LPG Boilers**

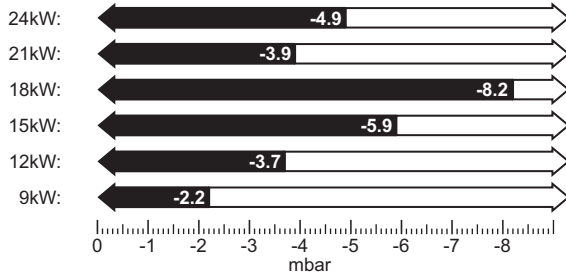

Fig. 54 Fan pressure readings

If the appliance fails the fan pressure test then before adjusting the air/gas ratio, try the following:

- ▶ Check the syphon is not blocked.
- 1. Remove the screws securing the sump cover.
- 2. Remove the sump cover.

3. Clean the sump with a suitable brush.

- ▶ Check the exhaust path and flue for restriction.
- ▶ Re-check the Fan Pressure readings

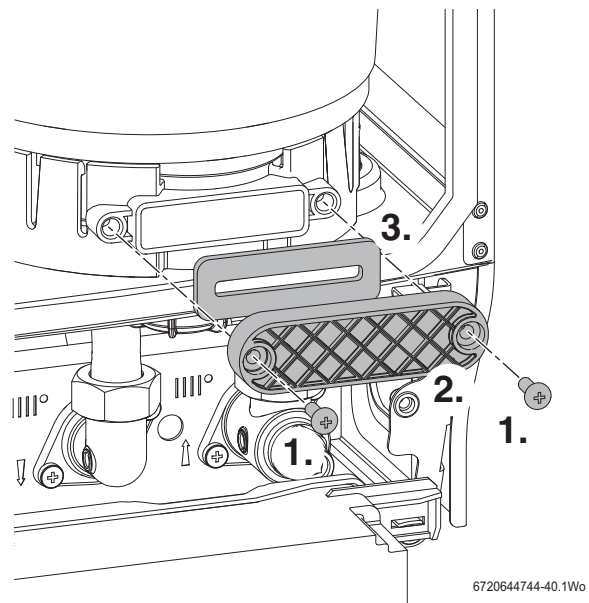

Fig. 55 Sump access

**7.5 FLUE GAS ANALYSIS**

**COMBUSTION TEST:**

**i** Ensure that the gas inlet pressure has been checked and is satisfactory, refer to section 6.5.1

- ▶ Connect the flue gas analyser to the flue gas sampling point as shown in the figure below.
- ▶ Run the appliance at maximum output for at least 10 minutes.
- ▶ Check the CO/CO<sub>2</sub> readings against the information in table 34 CO/CO<sub>2</sub> settings on page 47.

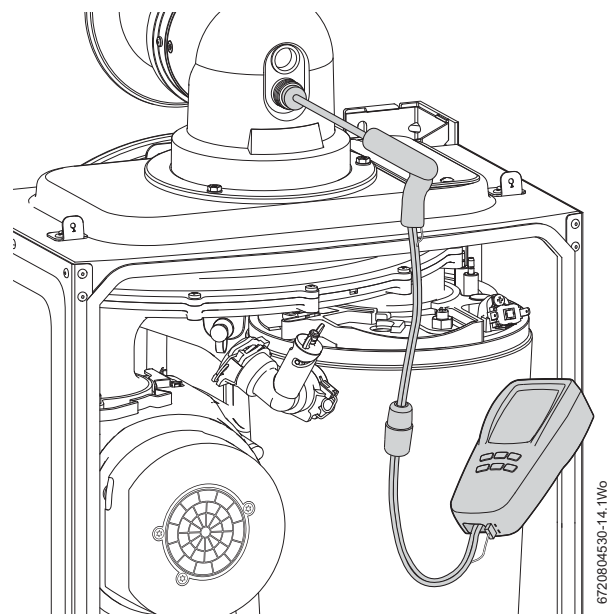

Fig. 56

If the appliance fails the combustion test, check:

1. Air intake for restriction
2. Diaphragm in the fan, for correct operation
3. Cleanliness of the heat cell, plus blockages in the condensate disposal.

**7.6 SETTING THE AIR/GAS RATIO**

**NOTICE:** THE SETTING OF THE GAS RATIO MUST BE CARRIED OUT BY A COMPETENT PERSON. SETTING OF THE GAS RATIO MUST NOT BE ATTEMPTED UNLESS THE PERSON CARRYING OUT THE TEST IS EQUIPPED WITH A COMBUSTION ANALYSER CONFORMING TO BS 7927 AND IS COMPETENT IN ITS USE.

**7.6.1 Setting the CO/CO<sub>2</sub>**

- ▶ Refer to section 7.2 and ensure that the gas inlet pressure is correct before continuing.
- ▶ To adjust the CO/CO<sub>2</sub> it will be necessary to first operate the appliance at maximum output.
- ▶ Refer to section 7.4 for setting the appliance to maximum and minimum output.
- ▶ Refer to table 34 and check the CO/CO<sub>2</sub> at maximum. If required set the maximum CO/CO<sub>2</sub> via adjuster (1) on the gas valve using a 2.5mm Allen key.
- ▶ Check CO is less than 200ppm.
- ▶ Set the control to minimum (MIN).
- ▶ The appliance will go to minimum power.
- ▶ Measure the CO/CO<sub>2</sub> and check against table 34. If required set the minimum CO/CO<sub>2</sub> via adjuster (2) on the gas valve until the correct measurement is set:
  - Remove dust cap with flat bladed screw driver.
  - Using a 4mm Allen key adjust CO<sub>2</sub>.
  - Replace the dust cap.
- ▶ Check that the CO is less than 200ppm.
- ▶ Return the appliance control to maximum and re-check the CO/CO<sub>2</sub>. If correct, set the appliance control to normal "NORM".
- ▶ Re-fit the control cover
- ▶ Re-fit appliance outer case.

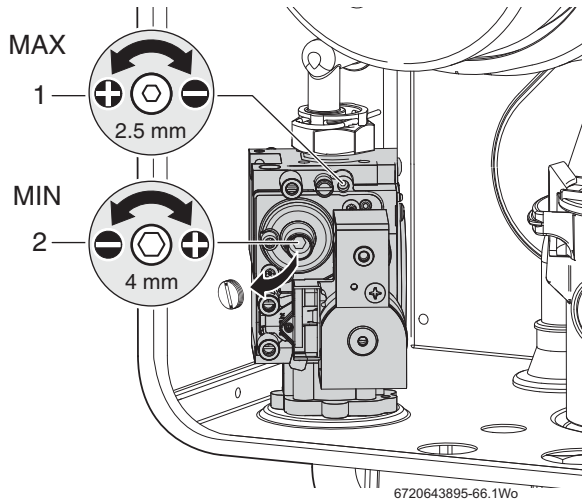

Fig. 57 Gas valve adjustment

| CO/CO <sub>2</sub> values                               |                      |                      |
|---|----------------------|----------------------|
| CO/CO <sub>2</sub> should be measured after 10 minutes. |                      |                      |
| Gas type  | CO <sub>2</sub> max. | CO <sub>2</sub> min. |
| Natural gas: 9 - 21kW outputs                           | 9.6% ± 0.5           | 8.6% ± 0.5           |
| Natural gas: 24kW output                                | 9.55% ± 0.5          | 8.55% ± 0.5          |
| LPG: All outputs  | 10.5% ± 0.5          | 10% ± 0.5            |

**NOTE:** When checking an existing appliance the tolerance is ± 0.5. If checking after cleaning or component replacement or for adjustment when the reading obtained is outside the tolerances given above, then the tolerance is ± 0.2.

**CO - less than 200 ppm (0.002 ratio)**

Table 34 CO/CO<sub>2</sub> settings

**7.7 CLEANING THE HEAT EXCHANGER**

**NOTICE: COMBUSTION TESTING**  
▶ Combustion testing must be carried out by a competent person. Testing must not be attempted unless the person carrying out the combustion check is equipped with a Combustion Analyser conforming to BS 7927 and is competent in its use.

**NOTICE: CO/CO<sub>2</sub> CHECKS**  
▶ If the joint between the Air/Gas manifold and heat exchanger is disturbed, replace the sealing gasket.  
▶ After completing the service of the appliance, the CO/CO<sub>2</sub> must be checked and set to the limits shown in "Setting the air/gas ratio" on page 47.

**i** There is a special accessory kit available specifically designed for cleaning the heat exchanger. If required order 7 716 192 312.

- ▶ Isolate the power to the appliance and remove outer case and base panel.

1. Refer to figure 58 and remove the clip from gas valve outlet.

**i** If the plastic elbow can not be easily removed, undo the nut to push the plastic elbow out of the fitting.

2. Pull the gas outlet elbow free from the gas valve.

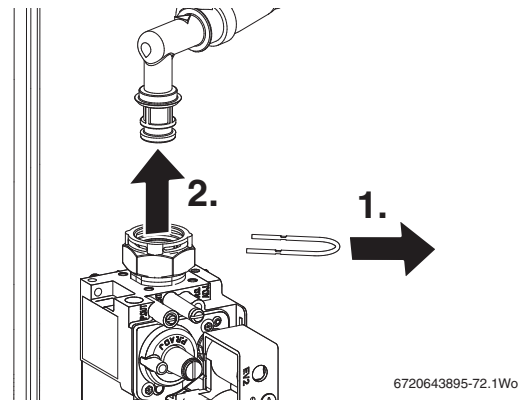

Fig. 58 Gas valve connection

- ▶ Remove electrical connector and earth wire from fan.

**i** To prevent damage to the electrodes when removing the air/gas manifold, disconnect the leads to the electrodes.

- ▶ Disconnect spark electrode and flame sensor connections.

1. Refer to figure 59 and undo the securing nut on the top of the heat exchanger and remove the retaining plate assembly.

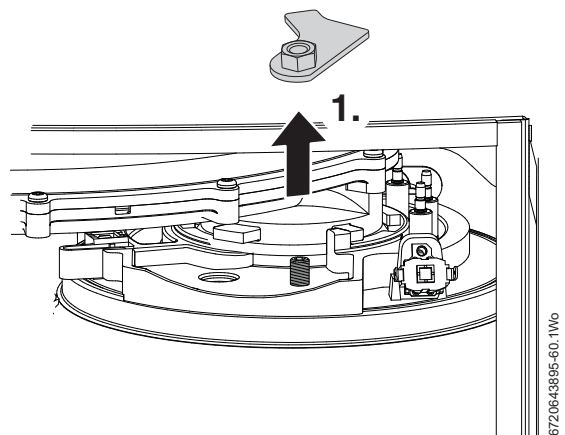

Fig. 59 Securing nut

1. Refer to figure 60 and rotate fan and air/gas manifold assembly around the top of the heat exchanger until it stops at the lug.
- ▶ Lift up assembly and remove from appliance.
2. Remove the cover panel by removing retaining screw.

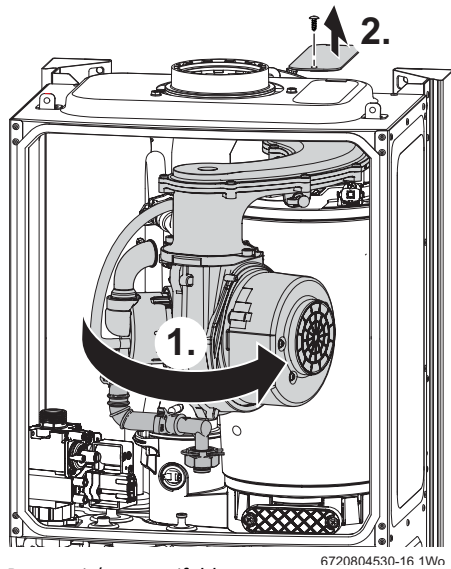

Fig. 60 Rotate air/gas manifold

**BURNER REMOVAL**

- Refer to figure 61
1. Remove clamping plate.
  2. Remove spark/flame electrode assembly and seal from the top of the heat exchanger.
  3. Remove burner.

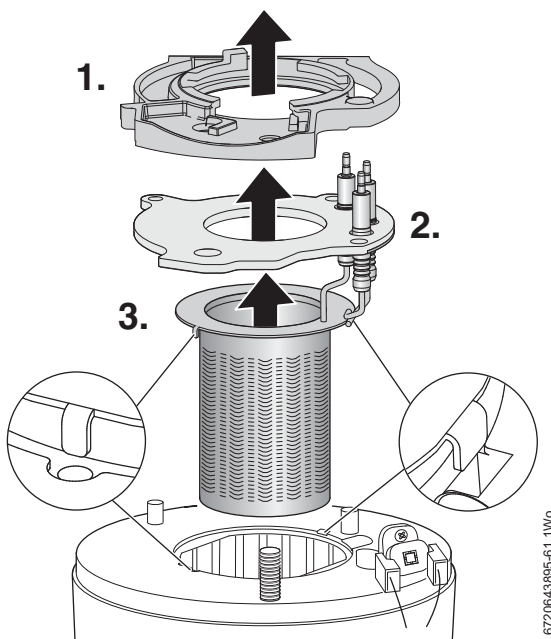

Fig. 61 Burner removal

**Checking and cleaning the electrode assembly:**

**NOTICE:** Cleaning

▶ Do not use wire wool to clean the electrodes

- ▶ Inspect the condition of the electrodes and ceramics, replace if necessary.
- ▶ Use a plastic scouring pad to clean the electrodes.

**BAFFLE REMOVAL**

1. Refer to figure 62 and remove top baffle.
2. Remove lower baffle.

**i** If the lower baffle is stuck, it may be necessary to use the "Baffle removal tool" from the heat exchanger cleaning kit - 7 716 192 312, as shown in figure 62.

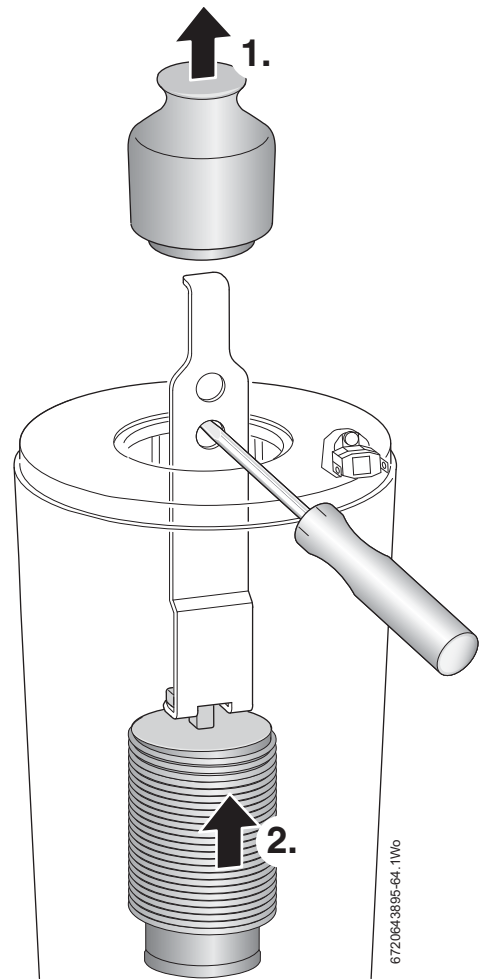

Fig. 62 Baffle removal

**ACCESS COVER REMOVAL**

- Refer to figure 63.
1. Remove the two pozi-drive screws
  2. Remove the access cover
  3. Remove the gasket.

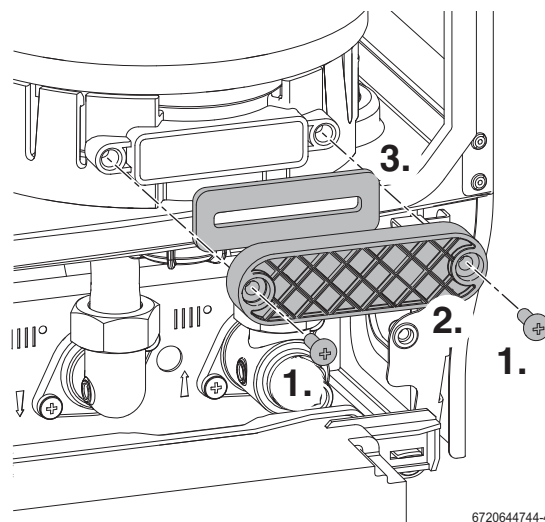

Fig. 63 Access cover removal

**CLEANING THE PRIMARY HEAT EXCHANGER**

- ▶ Refer to figure 64 and access the heat exchanger flue ways by inserting the cleaning brush (7 716 192 312) through the top access hole in the casing, removal of panel shown in figure 60.
- ▶ Clean heat exchanger flue ways using the cleaning brush removing any debris from the access point in the sump.
- ▶ Clean around the sealing surface on the sump.
- ▶ Replace the access cover.
- ▶ Using a suitable container to collect water from syphon connection at the base of the appliance flush heat exchanger with water.
- ▶ Re-assemble ensuring that the lower baffle (2) and the top baffle (1) are refitted correctly.
- ▶ Refer to figure 61 when re-fitting the burner to ensure that it fits centrally within the heat exchanger and location tabs are situated in location holes.
- ▶ Ensure that the seal is replaced with a new seal and ensure that the seal is correctly fitted.
  - For full details on refitting the seal and clamping plate assembly see section 7.8.11, Re-assembly of the burner clamping plate.
- ▶ Check the syphon unit is clean before refitting to appliance.
- ▶ Reassemble and check combustion as stated in “SETTING THE AIR/GAS RATIO” section on page 47.



**The heat exchanger does not need to be removed to clean.** The heat exchanger is shown removed from the appliance to illustrate cleaning more clearly.

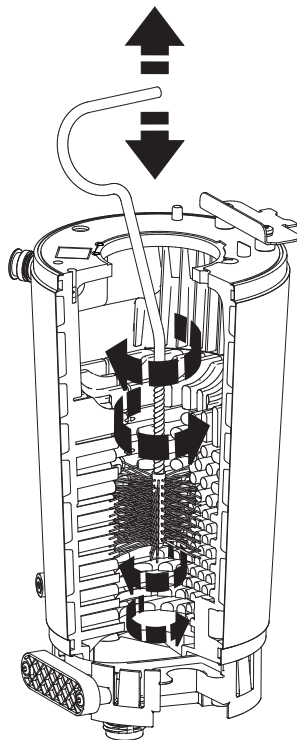

Fig. 64 Cleaning heat exchanger



**NOTICE:** Heat exchanger baffles.  
The baffles (1) and (2) must be refitted into the heat exchanger in the order shown in figure 62. Failure to do so may result in damage to the appliance.



**NOTICE: CO/CO<sub>2</sub> CHECKS**

- ▶ If the joint between the Air/Gas manifold and heat exchanger is disturbed, replace the sealing gasket.
- ▶ After completing the service of the appliance, the CO/CO<sub>2</sub> must be checked and set to the limits shown in “Setting the air/gas ratio” on page 47.
- ▶ When replacing the burner gasket ensure that the clamping plate is fully tightened down to the heat exchanger.

**7.7.1 SYPHON REMOVAL AND CLEANING**



Remove the syphon assembly to clean.

To release the syphon from the sump:

1. Undo the plastic nut on the bottom of the syphon and move the condensate pipe away from the syphon.
  2. Remove the two screws retaining the syphon bracket.
  3. Remove the bracket.
  4. Remove the screw and release the syphon retaining clamp
  5. Swing the clamp completely to the left away from the syphon
  6. Pull the syphon towards you and remove from the sump connection.
- ▶ Empty the contents of the syphon into a suitable container.
  - ▶ Flush the syphon through with clean water

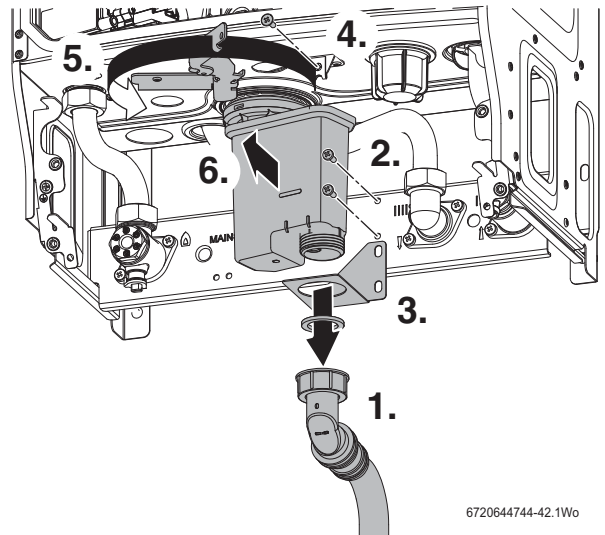

Fig. 65 Syphon removal

## 7.8 REPLACEMENT OF PARTS



**CAUTION:** TURN OFF THE GAS SUPPLY AND ISOLATE THE MAINS SUPPLIES BEFORE STARTING ANY WORK AND OBSERVE ALL RELEVANT SAFETY PRECAUTIONS.



**NOTICE:** REPLACEMENT OF COMPONENTS.

- ▶ After replacement of any components always check for gas tightness where relevant and carry out functional checks as described in Commissioning. Damaged O-rings or gaskets must be replaced.



Only use Worcester, Bosch Group original spare parts with this appliance. Non Worcester, Bosch Group original spare parts will invalidate the guarantee (if applicable) and any warranty.

- ▶ A comprehensive list of appliance spares can be found in the Spares Booklet.

### 7.8.1 REMOVING THE OUTER CASING

- ▶ Remove bottom tray by pressing the tabs (2) in, at the front underside of the appliance.
- ▶ Lower the panel.
- ▶ Pull the panel forward, off the retaining ledge (1) at the back of the appliance.

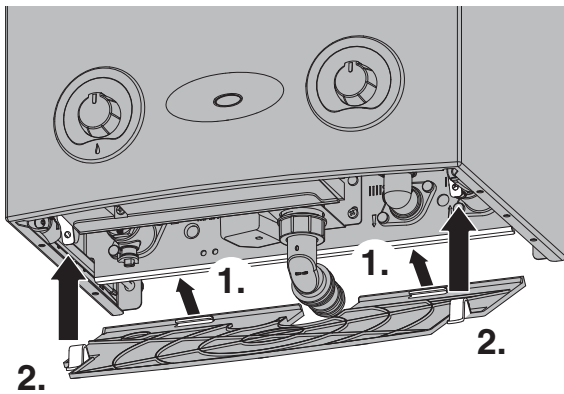

Fig. 66 Remove bottom panel

6720644744-34.1W0

1. Undo the two screws securing the top of the appliance casing.
  2. Undo the two screws securing the bottom of the appliance casing.
- ▶ Pull case forward and remove.

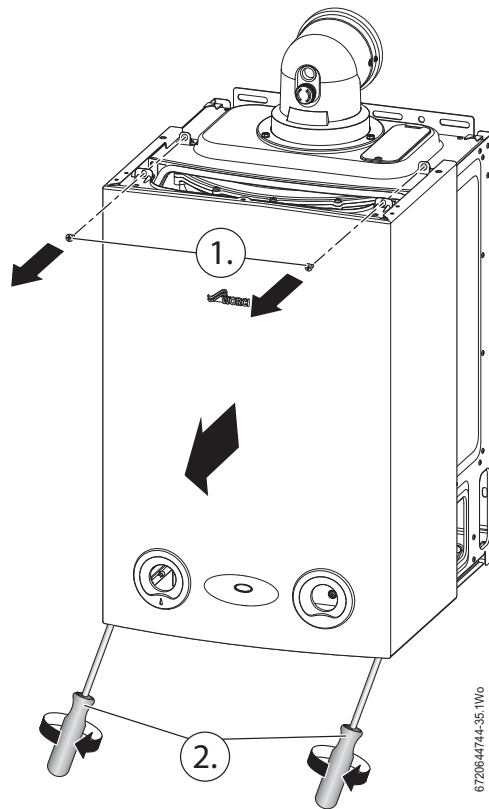

Fig. 67 Remove outer case

6720644744-35.1W0

### 7.8.2 PRIMARY SENSOR (CH NTC)



To gain access to the following components the outer case has to be removed:

- ▶ Primary sensor
- ▶ Overheat thermostat
- ▶ Flue limit thermostat

Refer to figure 68 for removal.

1. Remove electrical connection by pulling upwards. Squeeze retaining clip on plastic moulding of sensor and pull back and up until clear of pocket in heat exchanger.
  2. Pull forward to remove completely.
- ▶ Coat new sensor with heat conductive paste and replace.

### 7.8.3 OVERHEAT THERMOSTAT

Refer to figure 68 for removal.

- ▶ Remove two electrical connectors from thermostat.
- 3. Slacken and remove fixing screw and thermostat (3).
- ▶ When replacing ensure thermostat sits correctly on surface of the casting with the left hand side of thermostat sitting up against the shoulder.



It is essential that the mating surface of the thermostat is coated with heat conductive paste.

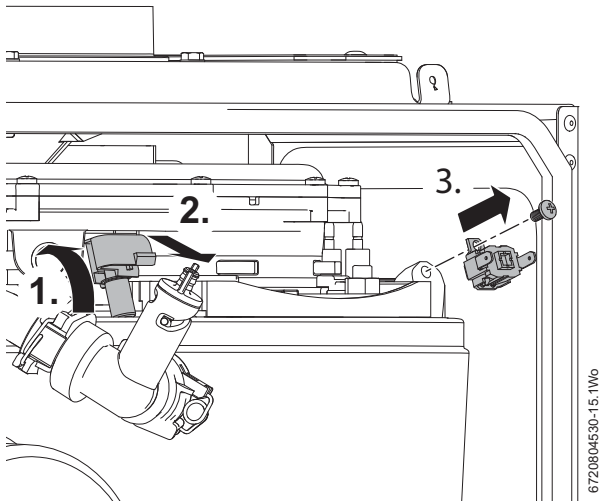

Fig. 68 Primary sensor and overheat thermostat

### 7.8.4 FLUE OVERHEAT THERMOSTAT (WITH GROMMET)

To remove and replace the thermostat either:

- ▶ Using a small terminal screwdriver, prise the thermostat and grommet from the plastic housing.  
Take care not to damage the plastic housing.

-or-

1. Release the flue connection from the sump.
2. Push the flue tube up.

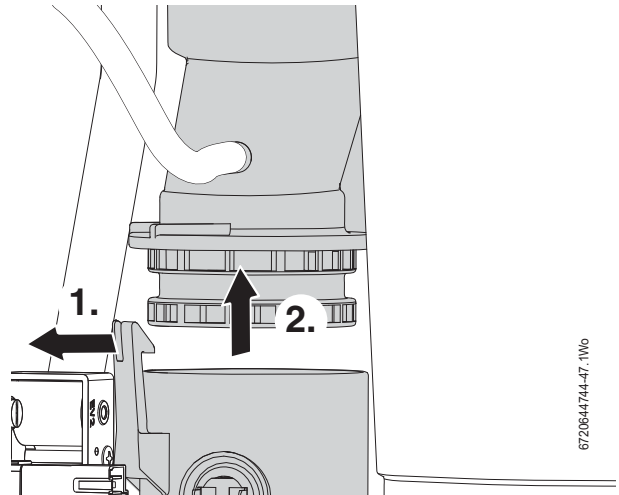

Fig. 69 Lower exhaust section

- ▶ Remove electrical connections.
- 1. Push the flue limit thermostat in from the sump.
- ▶ Retrieve the thermostat from the sump well.

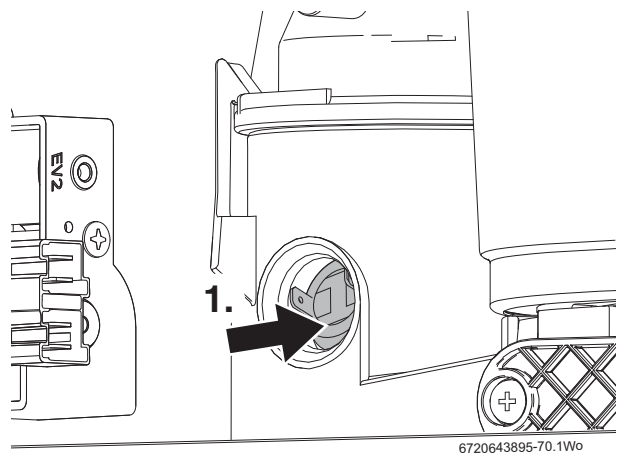

Fig. 70 Remove thermostat

To replace, push the thermostat and new grommet gently back into the opening until contact with the locating ridge is felt.

**7.8.5 LOWERING THE APPLIANCE CONTROLS TO THE SERVICE POSITION:**

1. Remove two screws securing control.
2. Pull the control forward.
3. Lower the control to align the slots at the top of the control with the lugs on the appliance framework.
4. Hang control on two lugs on appliance framework.

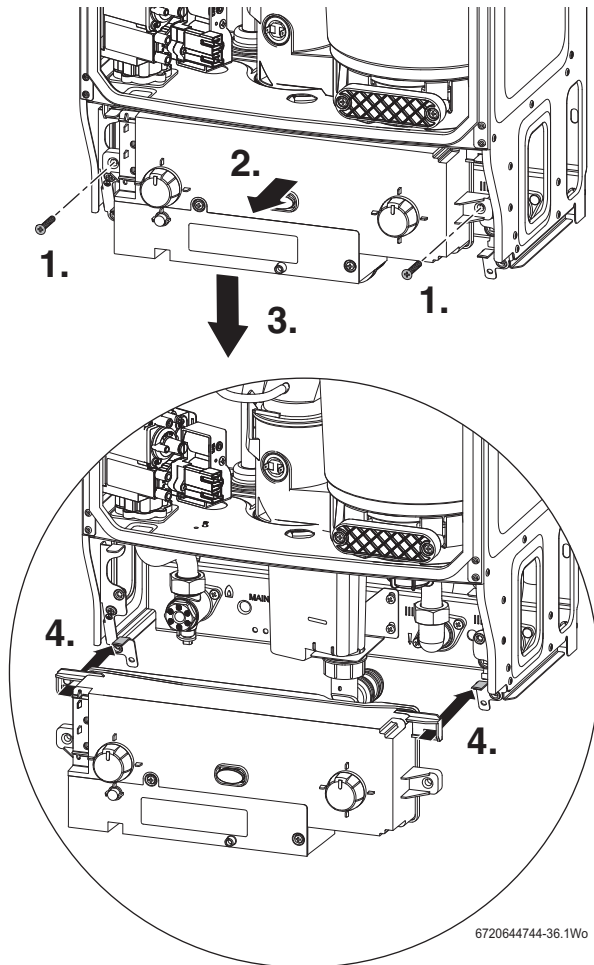

Fig. 71 Control panel into service position

**7.8.6 GAS VALVE**

- ▶ Isolate gas supply at appliance gas cock.
1. Refer to figure 72 and remove the wire clip from the gas valve outlet.
  2. Pull the gas pipe free from the gas valve.  
If the pipe will not pull out, unscrew the nut to aid removal.

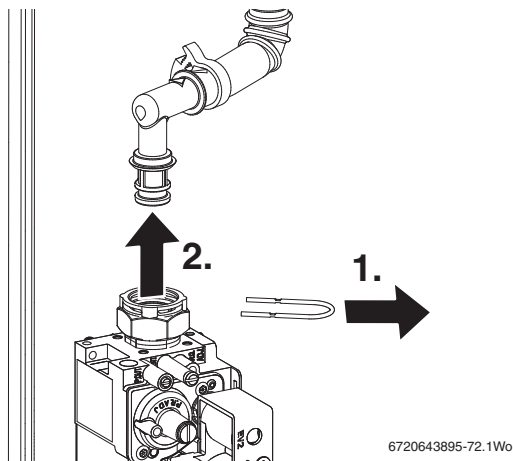

Fig. 72 Gas valve upper connection

1. Refer to figure 73 and undo bottom gas connection to gas valve.
  2. Undo two securing screws on the underside of casing.
- ▶ Disconnect electrical connections.
  - ▶ Pull valve up and forward out of appliance.
  - ▶ Replace valve with new seals and check for gas tightness.

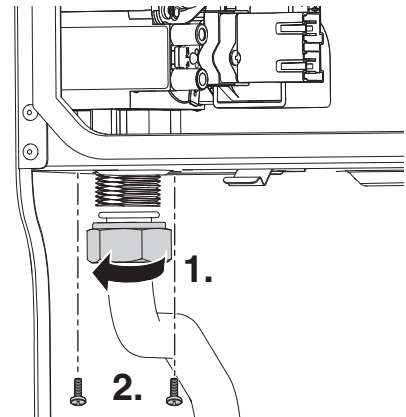

Fig. 73 Gas valve lower connection

**NOTICE:** The valve will require setting; follow procedure "Setting the air/gas ratio".

**7.8.7 AIR/GAS MANIFOLD AND FAN ASSEMBLY**

- i** The following components require the air/gas manifold and fan assembly to be removed:
  - ▶ Fan electrode assembly
  - ▶ Burner
  - ▶ Heat exchanger

**NOTICE:**

- ▶ If the joint between the Air/Gas manifold and heat exchanger is disturbed sealing gasket must be replaced.
- ▶ After re-assembly the combustion must be checked using the procedure in the section "Setting the Air/ Gas ratio". Measurement and setting (if necessary) of the gas ratio must not be attempted unless the person is equipped with a combustion analyser conforming to BS 7927 and is competent in its use.

- ▶ Remove electrical connector and earth wire the from fan.
- ▶ Remove wire clip from gas valve outlet then pull gas pipe free from the gas valve (see figure 72).

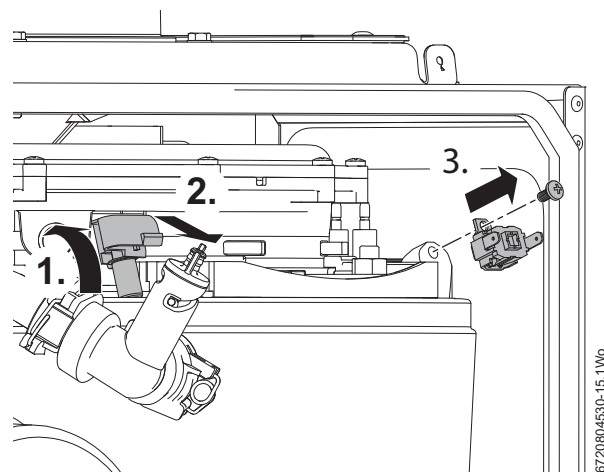

Fig. 74

- ▶ Undo the securing nut at the top of the heat exchanger and remove the retaining plate assembly (1).



Disconnect spark electrodes and flame sensor connection.  
This will prevent damage to the electrodes and sensor when the air/gas manifold is rotated.

1. Rotate fan and air/gas manifold assembly (1.) around the top of the heat exchanger until the lug on the air/gas manifold is visible.

- ▶ Lift up assembly and remove from appliance.

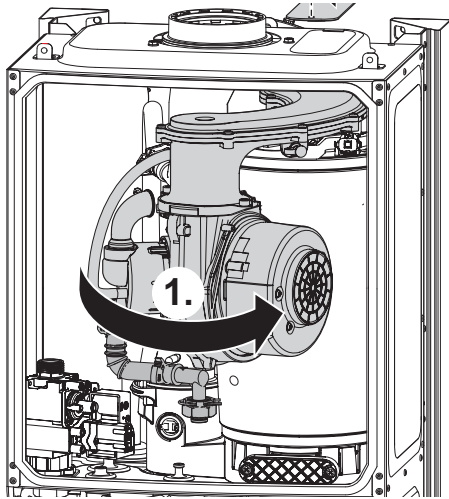

6720804530-16.1Wo

Fig. 75 Rotate the air/gas manifold assembly



**NOTICE:** After re-assembly, check the CO/CO<sub>2</sub> levels as described in section 7.6 Setting the air/gas ratio.

### 7.8.8 AIR PRESSURE SWITCH



**NOTICE:** Pressure switch  
▶ Ensure that the tube is reconnected to the pressure switch

1. Remove the electrical connections.
2. Slacken the top retaining screw and remove the bottom screw.
3. Disconnect the tube.
4. Remove the Air pressure switch assembly

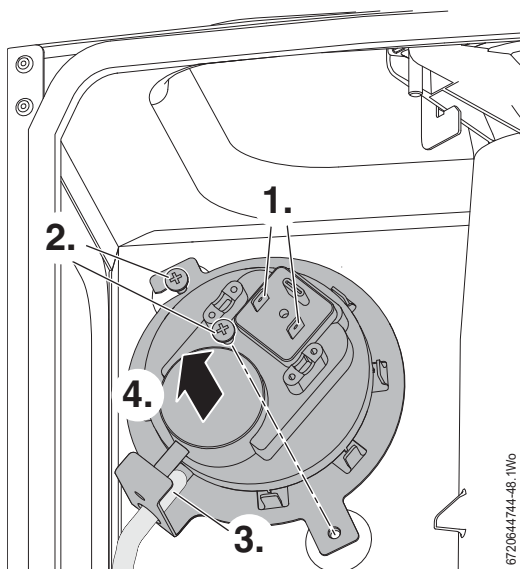

6720644744-48.1Wo

Fig. 76 Air pressure switch

1. Remove the two screws retaining the pressure switch to the bracket.
2. Refit the new Air pressure switch to the bracket.

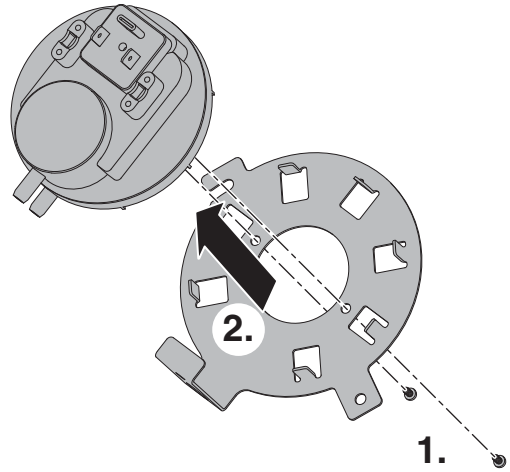

6720644744-48.1Wo

Fig. 77 Air pressure switch bracket



**NOTICE:** After re-assembly, check the CO/CO<sub>2</sub> levels as described in section 7.6 Setting the air/gas ratio.

### 7.8.9 FAN

- ▶ Remove the air/gas manifold from the appliance as described in the previous section.

1. Remove two screws retaining the fan to the air/gas manifold.
2. Remove the air/gas manifold.
3. Remove the screw holding the retaining plate.
4. Remove the retaining plate.
5. Remove three screws and the mixing chamber.

Re-assemble with new fan ensuring seals are correctly fitted.

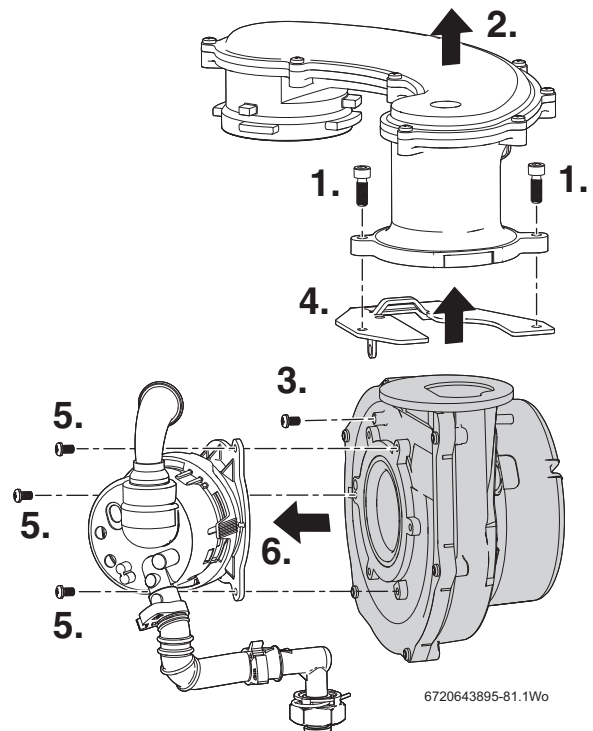

6720643895-81.1Wo

Fig. 78 Dismantling the air/gas manifold assembly

**FLAP VALVE ASSEMBLY**

1. Twist the mounting flange clockwise to release.
  2. Pull mounting flange off the flap valve assembly.
  3. Pull rubber flap off flap valve assembly.
- To replace the flap valve:
- Press the two lugs on the back of the flap into the two slots in the flap valve assembly.

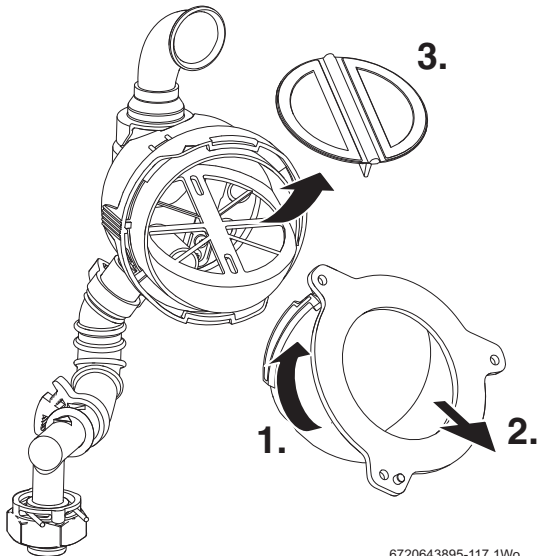

Fig. 79 Flap valve assembly

6720643895-117.1Wo

**7.8.10 ELECTRODE ASSEMBLY AND BURNER**

- Refer to figure 80 and disconnect spark electrodes and flame sensor connection.
- Remove clamping plate.
1. Remove spark/flame electrode assembly from heat exchanger.
  2. Remove the seal from the top of the heat exchanger.
  3. Remove the burner.
- Replace new burner in correct position.
- Ensure that burner tabs, as shown in figure 80, fit correctly their respective locations.

**NOTICE:** Heat exchanger seal

- If the joint between the Air/Gas manifold and heat exchanger is disturbed sealing gasket must be replaced.
- After re-assembly the combustion must be checked using the procedure in the section 7.6 "Setting the Air/Gas ratio".

- Ensure that the seal is fitted.

**CAUTION:** Clamping plate

- Ensure that the clamping plate is firmly tightened down on top of the heat exchanger.

- Replace the clamping plate.

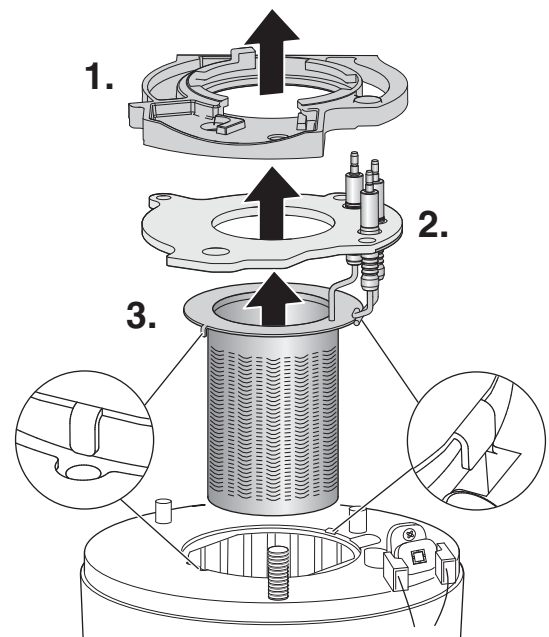

Fig. 80 Electrode assembly and burner

6720643895-61.1Wo

**7.8.11 RE-ASSEMBLY OF THE BURNER CLAMPING PLATE**

**NOTICE:** Heat exchanger seal

- If the joint between the Air/Gas manifold and heat exchanger is disturbed the sealing gasket must be replaced.
- After re-assembly the combustion must be checked using the procedure in the section 7.6 "Setting the Air/Gas ratio".

- Ensure that the new gasket is fitted, with the electrode assembly and gasket heat shield

**CAUTION:** Clamping plate

- Ensure that the clamping plate is firmly tightened down on top of the heat exchanger.

- Locate the edge of the clamping plate [7] under the bracket [4] and fit the retaining plate [1] hand tight
- Ensure that the retaining plate [1] is in the position shown in figure 81
- At this point the Air/Gas Manifold/Fan assembly [8] should be fitted, engage the lugs in the slots in the clamping plate and rotate clockwise to the stop position.
- Rotate the retaining plate assembly [1] in the slot on the clamping plate [2], this will prevent the Air/Gas manifold [8] rotating back
- Initially there will be a gap between the clamping plate and the top of the heat exchanger, refer to figure 81

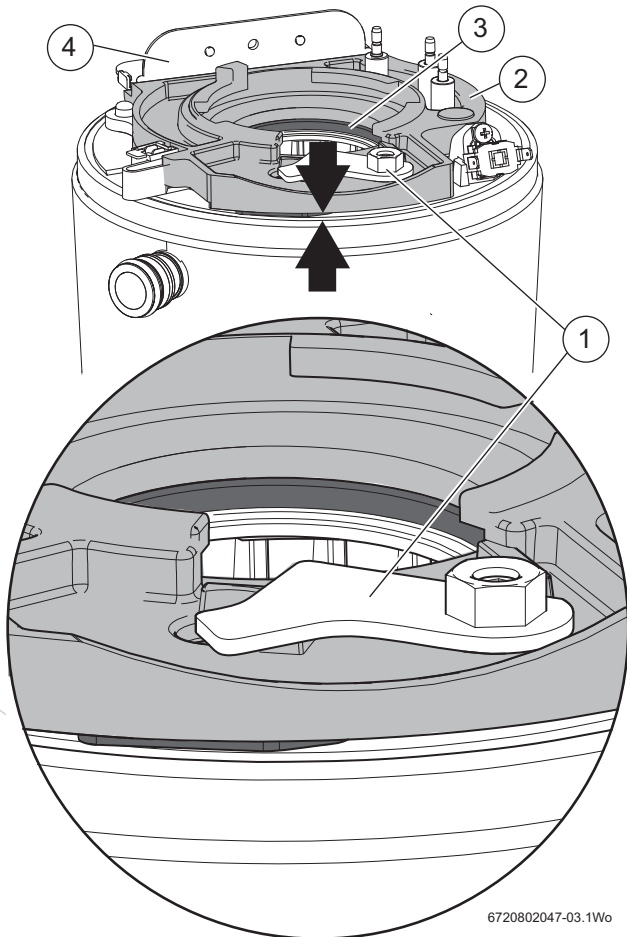

6720802047-03.1W6

Fig. 81 Initial location of the clamping plate

- [1] Retaining plate assembly
- [2] Clamping plate
- [3] Gasket
- [4] Bracket
- [5] Underside view of the clamping plate
- [6] Mating surface
- [7] Location edge
- [8] Air/Gas manifold assembly

- ▶ Tighten the nut on the retaining plate assembly [1] until the underside face of the clamping plate mates with the top of the heat exchanger as indicated by the two arrows in figure 83
- Refer to figure 82 for detail of the clamping and mating surface [6]
- ▶ It is important to clamp the plate down firmly, without over tightening, to the heat exchanger to ensure a gas tight seal

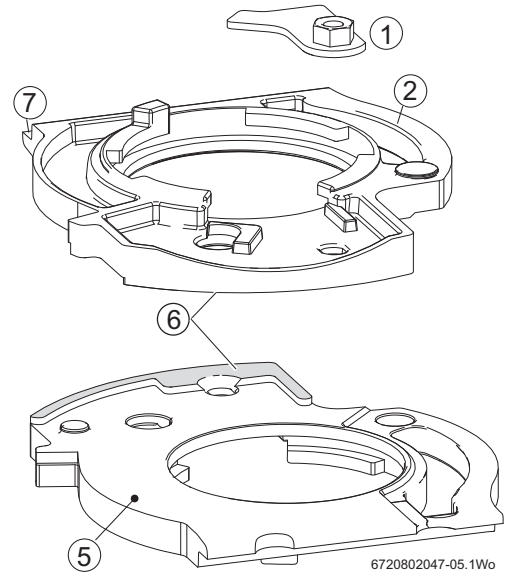

6720802047-05.1W6

Fig. 82 Clamping plate detail

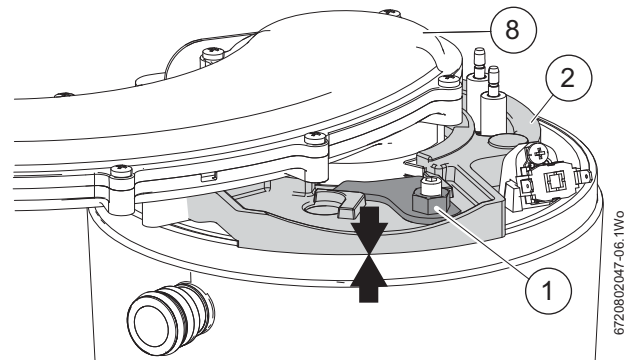

6720802047-06.1W6

Fig. 83 Clamping plate secured

### 7.8.12 HEAT EXCHANGER

- ▶ Drain the system.
  - ▶ Remove syphon.
  - ▶ Remove the air/gas manifold and fan.
1. Refer to figure 84, remove the clip from the elbow on the flow pipe.
  2. Pull flow pipe away from heat exchanger.

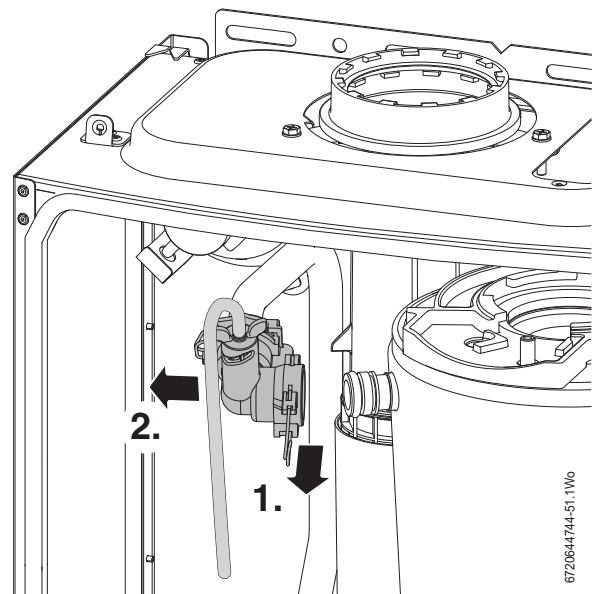

6720844744-51.1W6

Fig. 84 Flow pipe removal

1. Refer to figure 85 and re move the three screws securing the turret to the top of the appliance.
2. Turn the upper exhaust connector anti-clockwise to release from the hook.
3. Pull the upper exhaust connector down.

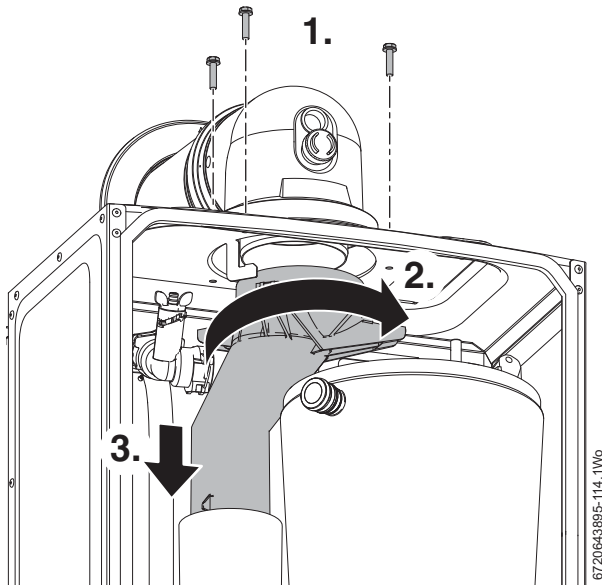

Fig. 85 Upper exhaust assembly

1. Refer to figure 86 and release the clip.
  2. Move the lower exhaust connector up
- Remove the complete exhaust assembly.

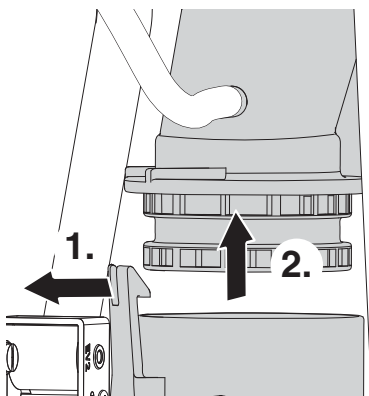

Fig. 86 Release lower exhaust connection

1. Refer to figure 87 and unscrew the plastic nut.
2. Remove the nut from the bottom of the appliance.
3. Rotate lever to release the return pipe.

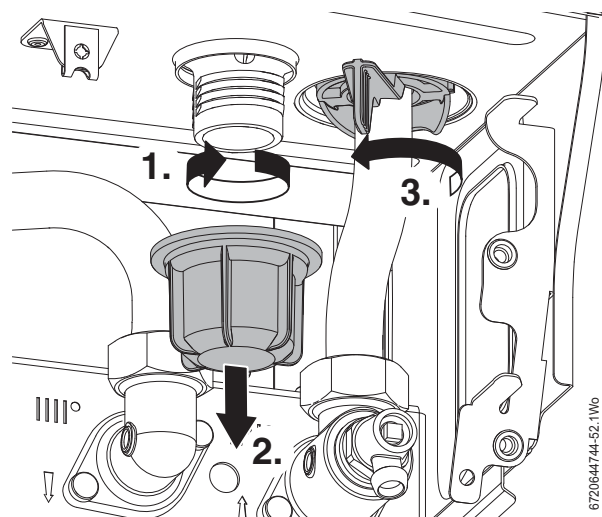

Fig. 87 Sump connections

1. Refer to figure 88 and lift the heat exchanger up to clear.
2. Pull the heat exchanger forward from the case.

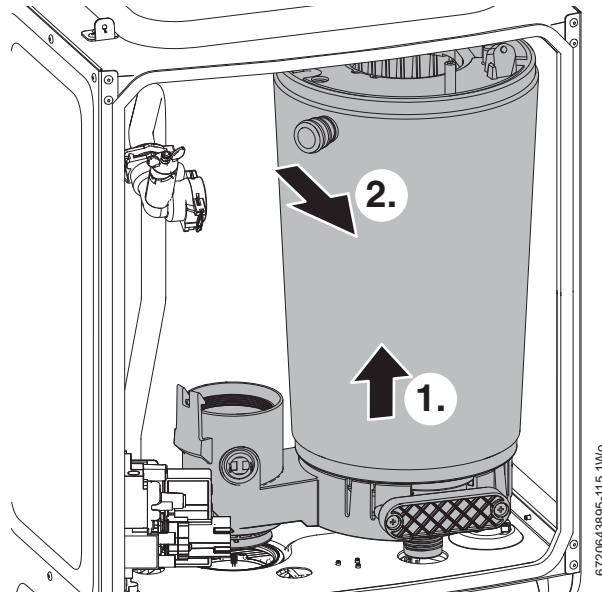

Fig. 88 Heat exchanger removal

- Reassemble and check combustion as stated in the air/gas ratio section. 7.6.



**NOTICE: CO/CO<sub>2</sub> CHECKS**

- If the joint between the Air/Gas manifold and heat exchanger is disturbed sealing gasket must be replaced.
- After completing the service of the appliance, the CO/CO<sub>2</sub> must be checked and set to the limits shown in "Setting the air/gas ratio" in section 7.6.

**7.8.13 SYPHON REMOVAL**

To release the syphon from the sump:

1. Undo the plastic nut on the bottom of the syphon and move the condensate pipe away from the syphon.
2. Remove the two screws retaining the syphon bracket.
3. Remove the bracket.
4. Remove the screw and release the syphon retaining clamp
5. Swing the clamp completely to the left away from the syphon
6. Pull the syphon towards you and remove from the sump connection.

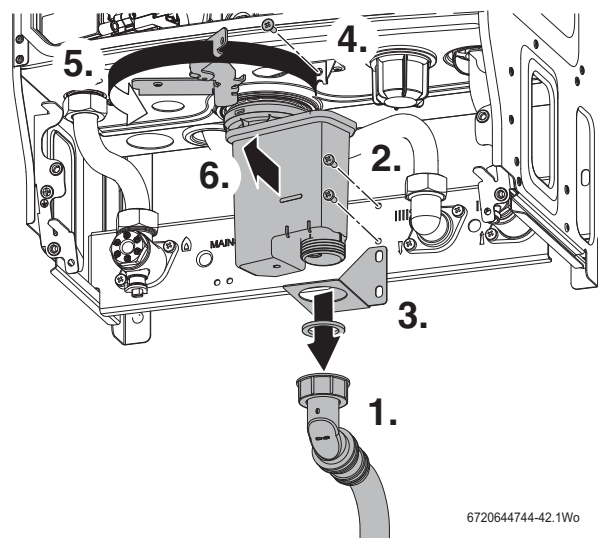

Fig. 89 Syphon removal

**7.8.14 ACCESS TO ELECTRICAL CONTROL PANEL**

- ▶ Remove three screws retaining the control cover (1).
- ▶ Remove the control cover [1].

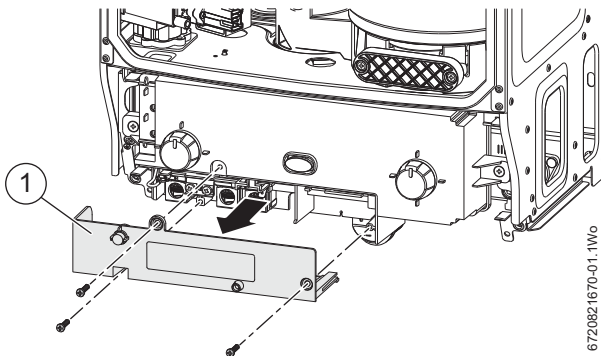

Fig. 90 Electrical control panel access

**7.8.15 PCB FUSE AND CODE PLUG**

PCB fuse and spare fuse

- ▶ Remove fuse holder with fuse F1 (1) from the control and replace with a new fuse.



A spare 2A fuse (3) for F1 is clipped onto the inside of the cover.

Code plug

- ▶ Gently pull the code plug from the socket (2).
- ▶ The code plug should be left attached to the frame of the appliance by its plastic safety thread.

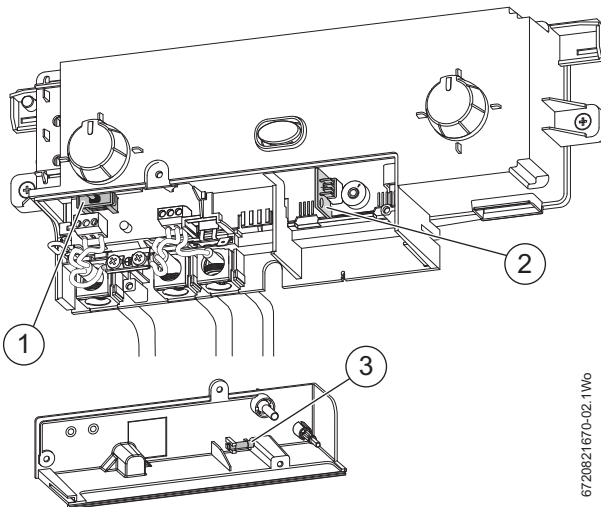

Fig. 91 PCB fuse and code plug location

**7.8.16 PCB**

- ▶ Remove two screws securing the control.
- ▶ Pull the control forward.
- ▶ Lower the control to align the slots at the top of the control with the lugs on the appliance framework.
- ▶ Hang control on two lugs on appliance framework.
- ▶ Unscrew the three screws in the control panel.
- ▶ Remove the connections cover and disconnect all electrical connections from the control.
- ▶ Gently pull the code plug from the socket (2), Figure 91.
- ▶ The code plug should be left attached to the frame of the appliance by its plastic safety thread.
- ▶ Remove the control from the appliance.
- ▶ Remove the four screws (3) retaining the rear panel (1) of the control.
- ▶ Remove the rear panel (1).
- ▶ Remove the printed circuit board.

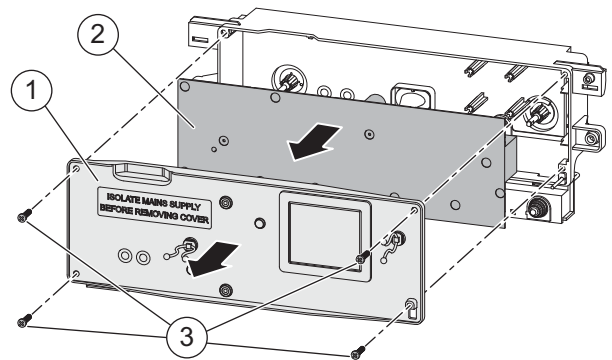

Fig. 92 PCB

- ▶ Refit the code plug [4] into the new control board.
- ▶ Re-assemble in reverse order.

**NOTICE: CODE PLUG**

- ▶ Ensure that the code plug is fitted to the new control.
- ▶ The appliance will indicate an error and will not function correctly if the code plug is not fitted.

**NOTICE: CO/CO<sub>2</sub>**

- ▶ After completing the service of the control, the CO/CO<sub>2</sub> must be checked and set to the limits shown in "Setting the air/gas ratio" in section 7.6.

## 8 FAULT FINDING AND DIAGNOSIS



This fault finding information is for guidance only. Worcester cannot be held responsible for costs incurred by persons not deemed to be competent.



This fault finding system assumes that the appliance has been operating normally until the time of failure (i.e. not a first time installation error).

### Basic checks

- Ensure that there is 230V power supply and the polarity is correct to the appliance.
- Ensure that the appliance settings and functionality is correct.
- Ensure the CH/DHW programmer/timer is functioning.
- Ensure the room thermostat is functioning.
- Ensure the cylinder thermostat (if fitted) is functioning.
- Ensure the cold water mains is turned on?
- Ensure the primary system has adequate pressure/system content for the system type.
- Ensure there is gas to the appliance?
  - Are other gas appliances working, gas cooker/hob for example?
  - Has the credit run out on the gas pre-payment meter?



#### NOTICE:

On completion of the Service/Fault-Finding task which has required the breaking and remaking of electrical connections, check:

- ▶ Earth continuity,
- ▶ Short circuit check,
- ▶ Polarity
- ▶ Resistance to earth.

**8.1 Fault finding**

| Blue light indication               | Fault  | Possible solution/check   |
|-------------------------------------|--|---|
| No light                            | No power at control board                    | <ul style="list-style-type: none"> <li>▶ Check               <ul style="list-style-type: none"> <li>- Mains supply voltage to the appliance.</li> <li>- Appliance mains switch is ON.</li> <li>- Fuse F1 - 2A Slow blow.</li> </ul> </li> <li>▶ Replace control board.</li> </ul>   |
| Light ON                            | Appliance ON but not operating during demand | <ul style="list-style-type: none"> <li>▶ Check               <ul style="list-style-type: none"> <li>- Live demand at ST2 terminal (L<sub>R</sub>) - is there a demand?</li> <li>- Manual bypass is open.</li> <li>- If Central Heating is working, check Hot Water controls.</li> <li>- If Hot Water is working, check Central Heating controls (i.e. external diverter valve, room thermostat/programmer, frost thermostat).</li> </ul> </li> <li>▶ Replace control board.</li> </ul>  |
| Slow flash (mostly off, flashes on) | Ignition lockout                             | <ul style="list-style-type: none"> <li>▶ Check               <ul style="list-style-type: none"> <li>- Gas present and at the correct pressure?</li> <li>- Gas valve:                   <ul style="list-style-type: none"> <li>• Is there 29V d.c. to each solenoid?</li> <li>• The resistance of each solenoid (→ 9.3.4).</li> </ul> </li> <li>- Combustion CO<sub>2</sub> level.</li> <li>- Blockage or restriction in the flue.</li> <li>- Gas valve adjustment.</li> <li>- Ignition electrodes/harness/connections.                   <ul style="list-style-type: none"> <li>• Condition and resistance of the leads (approximately 2,100 Ω).</li> </ul> </li> </ul> </li> <li>▶ Replace control board.</li> </ul> |
| Slow flash (mostly on, flashes off) | Flue overheat                                | <ul style="list-style-type: none"> <li>Flue temperature too high.</li> <li>▶ Check heat exchanger baffles are correctly fitted or removed and not refitted</li> </ul>   |
|                                     | Heat exchanger overheat                      | <ul style="list-style-type: none"> <li>▶ Check               <ul style="list-style-type: none"> <li>- Water pressure.</li> <li>- All air is vented.</li> <li>- Pump/harness/connections.</li> <li>- Water leaks/blockage.</li> <li>- Safety thermostats/low voltage wiring harness/connections.</li> <li>- Blocked heat exchanger.</li> </ul> </li> <li>▶ Replace control board.</li> </ul>   |
|                                     | Flue pressure switch                         | <ul style="list-style-type: none"> <li>▶ Check for blockage in the flue system.</li> </ul>  |
| Fast flash                          | Volatile lockout (sensor, fan or code plug)  | <ul style="list-style-type: none"> <li>▶ Check               <ul style="list-style-type: none"> <li>- Temperature sensors:                   <ul style="list-style-type: none"> <li>• Condition and resistance of the leads.</li> <li>• Resistance of sensor (→ 9.3.1).</li> </ul> </li> <li>- Fan.                   <ul style="list-style-type: none"> <li>• 230V A.C. across the live (purple) and neutral (brown)</li> </ul> </li> <li>- Fan lead continuity.</li> <li>- Code plug.                   <ul style="list-style-type: none"> <li>• Is code plug missing or not inserted properly?</li> </ul> </li> </ul> </li> </ul>  |
| 2 pulses                            |  | <ul style="list-style-type: none"> <li>▶ Check               <ul style="list-style-type: none"> <li>- Service mode switch is in "MIN" position?</li> </ul> </li> <li>▶ Return mode switch to "NORM" position if minimum test mode not required.</li> </ul>  |
| 5 pulses                            |  | <ul style="list-style-type: none"> <li>▶ Check               <ul style="list-style-type: none"> <li>- Service mode switch is in "MAX" position?</li> </ul> </li> <li>▶ Return mode switch to "NORM" position if maximum test mode not required.</li> </ul>  |

Table 35 Fault finding

**9 OPERATIONAL FUNCTIONS**

**9.1 Appliance function**

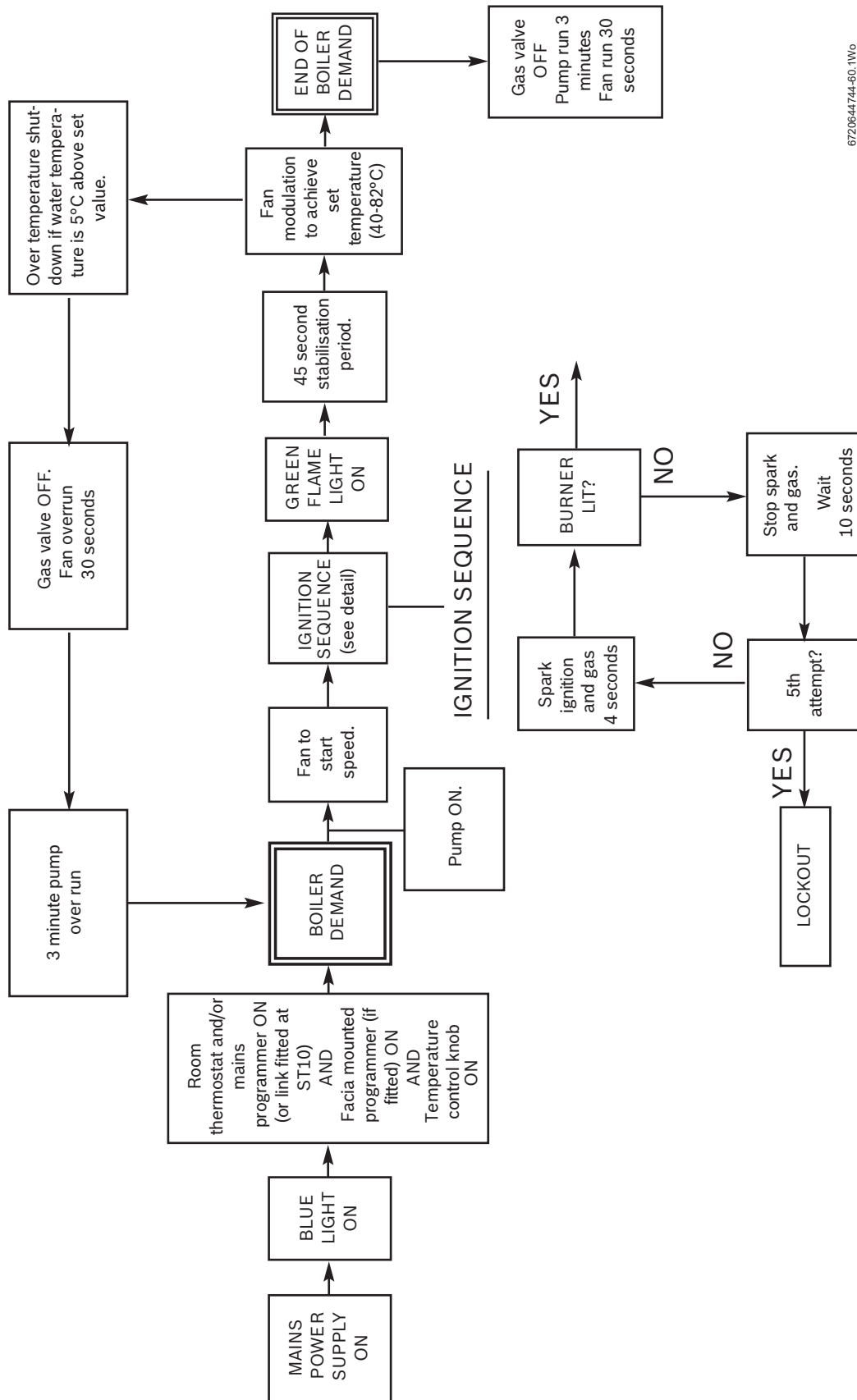

672084744-60-1Wo

Fig. 93 appliance function

**9.2 Protection function**

**AUTOMATIC INTERNAL FROST FUNCTION**

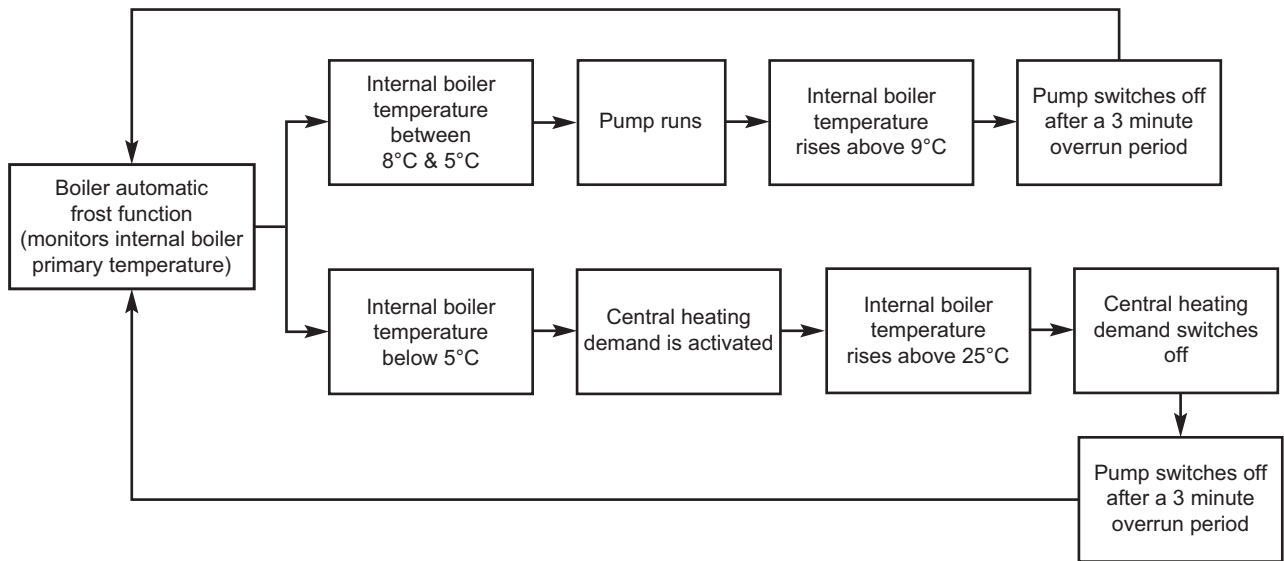

**PUMP OVERRUN FUNCTION**

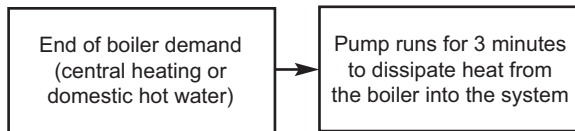

**PUMP ANTISEIZE FUNCTION**

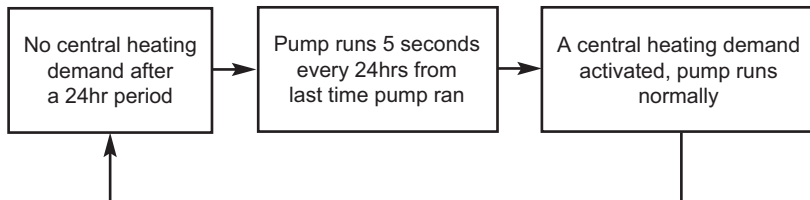

6720821670-06.1Wo

Fig. 94 Protection function

### 9.3 Component Characteristics

#### 9.3.1 Flow temperature (NTC) Sensor resistances

| Temperature [ °C ± 10%] | Resistance [ Ω] |
|-------------------------|-----------------|
| 0                       | 35,975          |
| 5                       | 28,516          |
| 10                      | 22,763          |
| 15                      | 18,279          |
| 20                      | 14,772          |
| 25                      | 11,981          |
| 30                      | 9,786           |
| 35                      | 8,047           |
| 40                      | 6,653           |
| 45                      | 5,523           |
| 50                      | 4,608           |
| 55                      | 3,856           |
| 60                      | 3,243           |
| 65                      | 2,744           |
| 70                      | 2,332           |
| 75                      | 1,990           |
| 80                      | 1,704           |
| 85                      | 1,464           |
| 90                      | 1,262           |
| 95                      | 1,093           |
| 100                     | 950             |

Table 36 Flow temperature sensor

#### 9.3.2 Flue overheat thermostat

| Normally closed thermostat | Temperature [ °C] | Resistance [ Ω] |
|----------------------------|-------------------|-----------------|
| Opening temperature        | ≥ 112             | 3,500           |
| Close temperature          | ≤ 111             | 6,500           |

Table 37 Flue overheat thermostat

#### 9.3.3 Overheat thermostat

| Normally closed thermostat | Temperature [ °C] | Resistance [ Ω] |
|----------------------------|-------------------|-----------------|
| Opening temperature        | ≥ 120             | ≤ 50M           |
| Close temperature          | ≤ 119             | 5,000           |

Table 38 Overheat thermostat

#### 9.3.4 Gas valve coil resistances

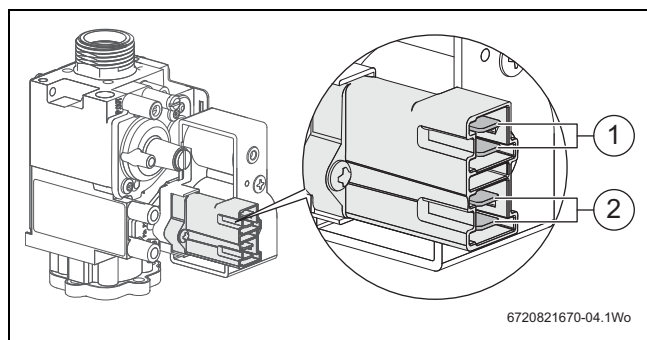

Fig. 95 Gas valve coil resistances

| Position |             | Resistance [ Ω ± 10%] |
|----------|-------------|-----------------------|
| 1        | Top coil    | 380 (342 - 418)       |
| 2        | Bottom coil | 190 (171 - 209)       |

Table 39 Gas valve coil resistances

#### 9.3.5 Code plug numbers

| Gas type    | Appliance  | Code plug number |
|-------------|------------|------------------|
| Natural Gas | 9Ri ErP +  | 050              |
|             | 12Ri ErP + | 051              |
|             | 15Ri ErP + | 052              |
|             | 18Ri ErP + | 053              |
|             | 21Ri ErP + | 054              |
|             | 24Ri ErP + | 055              |

Table 40 Natural Gas code plug numbers

| Gas type | Appliance  | Code plug number |
|----------|------------|------------------|
| LPG      | 9Ri ErP +  | 056              |
|          | 12Ri ErP + | 057              |
|          | 15Ri ErP + | 058              |
|          | 18Ri ErP + | 059              |
|          | 21Ri ErP + | 060              |
|          | 24Ri ErP + | 061              |

Table 41 LPG code plug numbers

## Notes

## Notes

## Notes

# GAS BOILER SYSTEM COMMISSIONING CHECKLIST

This Commissioning Checklist is to be completed in full by the competent person who commissioned the boiler as a means of demonstrating compliance with the appropriate Building Regulations and then handed to the customer to keep for future reference.

Failure to install and commission according to the manufacturer's instructions and complete this Benchmark Commissioning Checklist will invalidate the warranty. This does not affect the customer's statutory rights.

|  |  |  |  |  |  |                     |  |
|--|--|--|--|--|--|---------------------|--|
| Customer name:   |  |  |  | Telephone number:                            |  |                     |  |
| Address:   |  |  |  |  |  |                     |  |
| Boiler make and model:   |  |  |  |  |  |                     |  |
| Boiler serial number:  |  |  |  |  |  |                     |  |
| Commissioned by (PRINT NAME):  |  |  |  | Gas Safe register number:                    |  |                     |  |
| Company name:  |  |  |  | Telephone number:                            |  |                     |  |
| Company address:   |  |  |  |  |  |                     |  |
|  |  |  |  | Commissioning date:                          |  |                     |  |
| <b>To be completed by the customer on receipt of a Building Regulations Compliance Certificate*</b>                            |  |  |  |  |  |                     |  |
| Building Regulations Notification Number (if applicable):  |  |  |  |  |  |                     |  |
| <b>CONTROLS</b> (tick the appropriate boxes)   |  |  |  |  |  |                     |  |
| Time and temperature control to heating  |  | Room thermostat and programmer/timer     |  | Programmable room thermostat                 |  |                     |  |
|  |  | Load/weather compensation                |  | Optimum start control                        |  |                     |  |
| Time and temperature control to hot water  |  | Cylinder thermostat and programmer/timer |  | Combination Boiler                           |  |                     |  |
| Heating zone valves  |  | Fitted                                   |  | Not required                                 |  |                     |  |
| Hot water zone valves  |  | Fitted                                   |  | Not required                                 |  |                     |  |
| Thermostatic radiator valves   |  | Fitted                                   |  | Not required                                 |  |                     |  |
| Automatic bypass to system   |  | Fitted                                   |  | Not required                                 |  |                     |  |
| Boiler interlock   |  |  |  | Provided                                     |  |                     |  |
| <b>ALL SYSTEMS</b>   |  |  |  |  |  |                     |  |
| The system has been flushed and cleaned in accordance with BS7593 and boiler manufacturer's instructions                       |  |  |  |  |  | Yes                 |  |
| What system cleaner was used?  |  |  |  |  |  |                     |  |
| What inhibitor was used?   |  |  |  |  |  | Quantity            |  |
|  |  |  |  |  |  | litres              |  |
| Has a primary water system filter been installed?  |  |  |  |  |  | Yes                 |  |
|  |  |  |  |  |  | No                  |  |
| <b>CENTRAL HEATING MODE</b> measure and record:  |  |  |  |  |  |                     |  |
| Gas rate   |  | m <sup>3</sup> /hr                       |  | <b>OR</b>                                    |  | ft <sup>3</sup> /hr |  |
| Burner operating pressure (if applicable)  |  | mbar                                     |  | <b>OR</b> Gas inlet pressure                 |  | mbar                |  |
| Central heating flow temperature   |  |  |  |  |  | °C                  |  |
| Central heating return temperature   |  |  |  |  |  | °C                  |  |
| <b>COMBINATION BOILERS ONLY</b>  |  |  |  |  |  |                     |  |
| Is the installation in a hard water area (above 200ppm)?   |  |  |  |  |  | Yes                 |  |
|  |  |  |  |  |  | No                  |  |
| If yes, and if required by the manufacturer, has a water scale reducer been fitted?  |  |  |  |  |  | Yes                 |  |
|  |  |  |  |  |  | No                  |  |
| What type of scale reducer has been fitted?  |  |  |  |  |  |                     |  |
| <b>DOMESTIC HOT WATER MODE</b> Measure and Record:   |  |  |  |  |  |                     |  |
| Gas rate   |  | m <sup>3</sup> /hr                       |  | <b>OR</b>                                    |  | ft <sup>3</sup> /hr |  |
| Burner operating pressure (at maximum rate)  |  | mbar                                     |  | <b>OR</b> Gas inlet pressure at maximum rate |  | mbar                |  |
| Cold water inlet temperature   |  |  |  |  |  | °C                  |  |
| Hot water has been checked at all outlets  |  |  |  |  |  | Yes                 |  |
|  |  |  |  |  |  | Temperature         |  |
|  |  |  |  |  |  | °C                  |  |
| Water flow rate  |  |  |  |  |  | l/min               |  |
| <b>CONDENSING BOILERS ONLY</b>   |  |  |  |  |  |                     |  |
| The condensate drain has been installed in accordance with the manufacturer's instructions and/or BS5546/BS6798                |  |  |  |  |  | Yes                 |  |
| <b>ALL INSTALLATIONS</b>   |  |  |  |  |  |                     |  |
| Record the following:  |  | At max. rate:                            |  | CO   |  | ppm                 |  |
|  |  | <b>AND</b>                               |  | CO/CO <sub>2</sub>                           |  | Ratio               |  |
|  |  | At min. rate: (where possible)           |  | CO   |  | ppm                 |  |
|  |  | <b>AND</b>                               |  | CO/CO <sub>2</sub>                           |  | Ratio               |  |
| The heating and hot water system complies with the appropriate Building Regulations  |  |  |  |  |  | Yes                 |  |
| The boiler and associated products have been installed and commissioned in accordance with the manufacturer's instructions     |  |  |  |  |  | Yes                 |  |
| The operation of the boiler and system controls have been demonstrated to and understood by the customer                       |  |  |  |  |  | Yes                 |  |
| The manufacturer's literature, including Benchmark Checklist and Service Record, has been explained and left with the customer |  |  |  |  |  | Yes                 |  |
| Commissioning Engineer's Signature   |  |  |  |  |  |                     |  |
| Customer's Signature   |  |  |  |  |  |                     |  |
| (To confirm satisfactory demonstration and receipt of manufacturer's literature)   |  |  |  |  |  |                     |  |

\*All installations in England and Wales must be notified to Local Authority Building Control (LABC) either directly or through a Competent Persons Scheme. A Building Regulations Compliance Certificate will then be issued to the customer.



# SERVICE RECORD

It is recommended that your heating system is serviced regularly and that the appropriate Service Interval Record is completed.

## Service Provider

Before completing the appropriate Service Record below, please ensure you have carried out the service as described in the manufacturer's instructions. Always use the manufacturer's specified spare part when replacing controls.

|                       |                                |    |     |            |                   |
|-----------------------|--------------------------------|----|-----|------------|-------------------|
| <b>SERVICE 01</b>     |                                |    |     |            | Date:             |
| Engineer name:        |                                |    |     |            |                   |
| Company name:         |                                |    |     |            |                   |
| Telephone No:         |                                |    |     |            |                   |
| Gas safe register No: |                                |    |     |            |                   |
| Record:               | At max. rate:                  | CO | ppm | <b>AND</b> | CO <sub>2</sub> % |
|                       | At min. rate: (Where Possible) | CO | ppm | <b>AND</b> | CO <sub>2</sub> % |
| Comments:             |                                |    |     |            |                   |
| Signature             |                                |    |     |            |                   |

|                       |                                |    |     |            |                   |
|-----------------------|--------------------------------|----|-----|------------|-------------------|
| <b>SERVICE 02</b>     |                                |    |     |            | Date:             |
| Engineer name:        |                                |    |     |            |                   |
| Company name:         |                                |    |     |            |                   |
| Telephone No:         |                                |    |     |            |                   |
| Gas safe register No: |                                |    |     |            |                   |
| Record:               | At max. rate:                  | CO | ppm | <b>AND</b> | CO <sub>2</sub> % |
|                       | At min. rate: (Where Possible) | CO | ppm | <b>AND</b> | CO <sub>2</sub> % |
| Comments:             |                                |    |     |            |                   |
| Signature             |                                |    |     |            |                   |

|                       |                                |    |     |            |                   |
|-----------------------|--------------------------------|----|-----|------------|-------------------|
| <b>SERVICE 03</b>     |                                |    |     |            | Date:             |
| Engineer name:        |                                |    |     |            |                   |
| Company name:         |                                |    |     |            |                   |
| Telephone No:         |                                |    |     |            |                   |
| Gas safe register No: |                                |    |     |            |                   |
| Record:               | At max. rate:                  | CO | ppm | <b>AND</b> | CO <sub>2</sub> % |
|                       | At min. rate: (Where Possible) | CO | ppm | <b>AND</b> | CO <sub>2</sub> % |
| Comments:             |                                |    |     |            |                   |
| Signature             |                                |    |     |            |                   |

|                       |                                |    |     |            |                   |
|-----------------------|--------------------------------|----|-----|------------|-------------------|
| <b>SERVICE 04</b>     |                                |    |     |            | Date:             |
| Engineer name:        |                                |    |     |            |                   |
| Company name:         |                                |    |     |            |                   |
| Telephone No:         |                                |    |     |            |                   |
| Gas safe register No: |                                |    |     |            |                   |
| Record:               | At max. rate:                  | CO | ppm | <b>AND</b> | CO <sub>2</sub> % |
|                       | At min. rate: (Where Possible) | CO | ppm | <b>AND</b> | CO <sub>2</sub> % |
| Comments:             |                                |    |     |            |                   |
| Signature             |                                |    |     |            |                   |

|                       |                                |    |     |            |                   |
|-----------------------|--------------------------------|----|-----|------------|-------------------|
| <b>SERVICE 05</b>     |                                |    |     |            | Date:             |
| Engineer name:        |                                |    |     |            |                   |
| Company name:         |                                |    |     |            |                   |
| Telephone No:         |                                |    |     |            |                   |
| Gas safe register No: |                                |    |     |            |                   |
| Record:               | At max. rate:                  | CO | ppm | <b>AND</b> | CO <sub>2</sub> % |
|                       | At min. rate: (Where Possible) | CO | ppm | <b>AND</b> | CO <sub>2</sub> % |
| Comments:             |                                |    |     |            |                   |
| Signature             |                                |    |     |            |                   |

|                       |                                |    |     |            |                   |
|-----------------------|--------------------------------|----|-----|------------|-------------------|
| <b>SERVICE 06</b>     |                                |    |     |            | Date:             |
| Engineer name:        |                                |    |     |            |                   |
| Company name:         |                                |    |     |            |                   |
| Telephone No:         |                                |    |     |            |                   |
| Gas safe register No: |                                |    |     |            |                   |
| Record:               | At max. rate:                  | CO | ppm | <b>AND</b> | CO <sub>2</sub> % |
|                       | At min. rate: (Where Possible) | CO | ppm | <b>AND</b> | CO <sub>2</sub> % |
| Comments:             |                                |    |     |            |                   |
| Signature             |                                |    |     |            |                   |

|                       |                                |    |     |            |                   |
|-----------------------|--------------------------------|----|-----|------------|-------------------|
| <b>SERVICE 07</b>     |                                |    |     |            | Date:             |
| Engineer name:        |                                |    |     |            |                   |
| Company name:         |                                |    |     |            |                   |
| Telephone No:         |                                |    |     |            |                   |
| Gas safe register No: |                                |    |     |            |                   |
| Record:               | At max. rate:                  | CO | ppm | <b>AND</b> | CO <sub>2</sub> % |
|                       | At min. rate: (Where Possible) | CO | ppm | <b>AND</b> | CO <sub>2</sub> % |
| Comments:             |                                |    |     |            |                   |
| Signature             |                                |    |     |            |                   |

|                       |                                |    |     |            |                   |
|-----------------------|--------------------------------|----|-----|------------|-------------------|
| <b>SERVICE 08</b>     |                                |    |     |            | Date:             |
| Engineer name:        |                                |    |     |            |                   |
| Company name:         |                                |    |     |            |                   |
| Telephone No:         |                                |    |     |            |                   |
| Gas safe register No: |                                |    |     |            |                   |
| Record:               | At max. rate:                  | CO | ppm | <b>AND</b> | CO <sub>2</sub> % |
|                       | At min. rate: (Where Possible) | CO | ppm | <b>AND</b> | CO <sub>2</sub> % |
| Comments:             |                                |    |     |            |                   |
| Signature             |                                |    |     |            |                   |

|                       |                                |    |     |            |                   |
|-----------------------|--------------------------------|----|-----|------------|-------------------|
| <b>SERVICE 09</b>     |                                |    |     |            | Date:             |
| Engineer name:        |                                |    |     |            |                   |
| Company name:         |                                |    |     |            |                   |
| Telephone No:         |                                |    |     |            |                   |
| Gas safe register No: |                                |    |     |            |                   |
| Record:               | At max. rate:                  | CO | ppm | <b>AND</b> | CO <sub>2</sub> % |
|                       | At min. rate: (Where Possible) | CO | ppm | <b>AND</b> | CO <sub>2</sub> % |
| Comments:             |                                |    |     |            |                   |
| Signature             |                                |    |     |            |                   |

|                       |                                |    |     |            |                   |
|-----------------------|--------------------------------|----|-----|------------|-------------------|
| <b>SERVICE 10</b>     |                                |    |     |            | Date:             |
| Engineer name:        |                                |    |     |            |                   |
| Company name:         |                                |    |     |            |                   |
| Telephone No:         |                                |    |     |            |                   |
| Gas safe register No: |                                |    |     |            |                   |
| Record:               | At max. rate:                  | CO | ppm | <b>AND</b> | CO <sub>2</sub> % |
|                       | At min. rate: (Where Possible) | CO | ppm | <b>AND</b> | CO <sub>2</sub> % |
| Comments:             |                                |    |     |            |                   |
| Signature             |                                |    |     |            |                   |

\*All installations in England and Wales must be notified to Local Authority Building Control (LABC) either directly or through a Competent Persons Scheme. A Building Regulations Compliance Certificate will then be issued to the customer.



Worcester, Bosch Group  
Cotswold Way, Warndon, Worcester WR4 9SW.  
Tel. 0330 123 9559

Worcester, Bosch Group is a brand name of Bosch Thermotechnology Ltd.  
[worcester-bosch.co.uk](http://worcester-bosch.co.uk)

6 720 821 670 (2018/06)

**WORCESTER, BOSCH GROUP:**

|                    |               |
|--------------------|---------------|
| TECHNICAL SUPPORT: | 0330 123 3366 |
| APPOINTMENTS:      | 0330 123 9339 |
| SPARES:            | 0330 123 9779 |
| LITERATURE:        | 0330 123 9119 |
| TRAINING:          | 0330 123 0166 |
| SALES:             | 0330 123 9669 |



**WORCESTER**  
**Bosch Group**