

Right Angle Fixing Clip

CODE **G246**

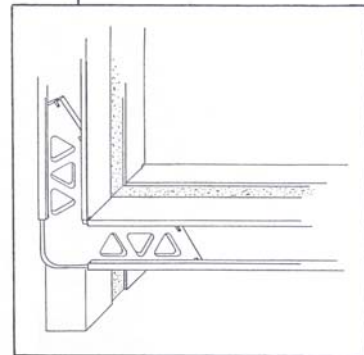
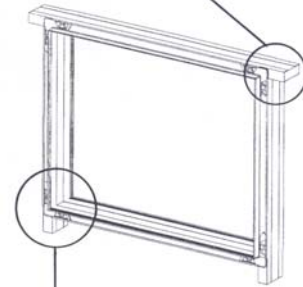
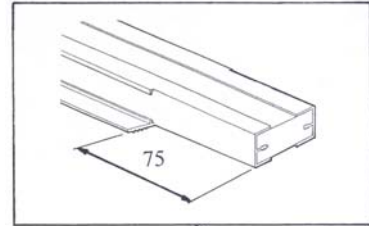
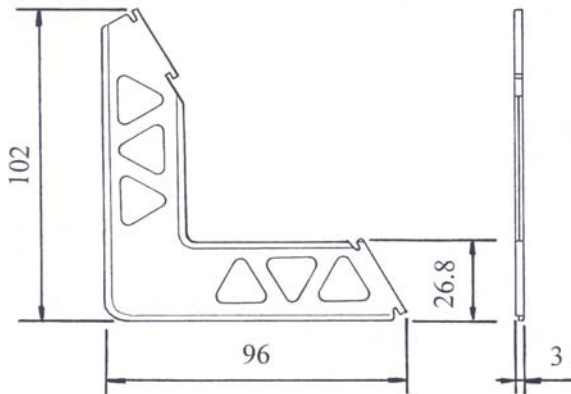
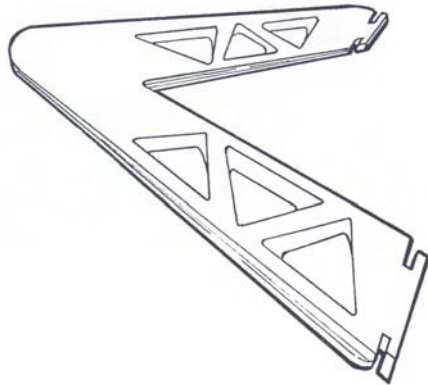

Description:

The G246 Right Angle Fixing Clip is used to form cavity frames.

Fitting Instructions:

Firstly cut and trim four lengths of cavity closer to size.
 Note the fixing channel will require trimming back 75mm to enable fitment of the tie as shown.
 Now assemble corners by pushing eight G246 Right Angle Fixing Clips into the fixing channel as shown.

COLOURS	Black
PACKING DETAILS	Packed in 50's in cardboard box.
WEIGHT	0.4kg per pack
MATERIAL	Polypropylene
MANUFACTURING PROCESS	Injection Moulded

Calculation Of Ties:

For ordering purposes Manthorpe recommends eight fixing clips should be ordered per 2.44m length of cavity closer.

MANTHORPE BUILDING PRODUCTS LTD
 MANTHORPE HOUSE
 BRITAIN DRIVE
 CODNOR GATE BUSINESS PARK
 RIPLEY
 DERBYSHIRE DE5 3ND

TEL: 01773 514 200
 FAX: 01773 514 262
 EMAIL: sales@manthorpe.co.uk
 WEB: www.manthorpe.co.uk

DRN M.L.W.O

Date 01.08.03

DRG No

Issue

The company maintains a policy of continuous development of its product range and reserves the right to amend the specification without notice.

MBP 8091

A