

**Roll-Out Clay Hip System - Overview**

CODE **GDRH-CL**

**Description**

The Manthorpe Roll-Out Clay Hip is a mechanically fitted system which securely fixes the hip tiles on to a roof. Due to the nature in which the system is fitted, there is no need for mortar, making the job of fixing the hip quick, easy, and clean, as well as making it possible during frosts and other adverse weather conditions.

The system is designed to suit traditionally deeper clay hip tiles (both round and angled), but is also compatible with concrete tiles and can be fitted onto most roof coverings, including profiled tiles. The system can be fitted on most pitches and plan angles of roof (pitches must be within tile manufacturers recommendations for the tile type being used).

A single box of the dry hip system provides all of the components required for a hip run approximately 6 metres in length (excluding the hip tiles).

The system is available in 2 different colours (Black and Dark Brown) and can be used in conjunction with Manthorpe's roll-out ridge system. Specifiers should ensure that dry fix roofing systems are compatible with their detail prior to installation.

**Features:**

- A mechanically fixed system for securing clay hip tiles without the need for mortar and pointing.
- The hip support tray levels out the run of the hip to provide a level mounting for the hip tiles.
- One box provides all of the components required for a 6 metre hip run with 450mm long tiles (excludes tiles).
- Additional unions available for use with shorter ridge tiles.
- Compatible with most makes of clay and concrete hip tiles; both round and angled.
- Can be fitted to the hip of most roof pitches (pitches must be within tile manufacturers recommendations for the tile type being used)
- The system can be fitted onto most slate, clay and concrete roof coverings, including profiled tiles.
- Quick and easy to fix with no special tool requirements.
- Available in 2 different colours (Black and Dark Brown)
- Hip ends can be finished off with Manthorpe's unique hip end closer.

**References**

BS 5250 Control of Condensation in Building  
 BS 5534 Code of Practice for Slate and Tiling  
 BS EN 1991-1-4 Actions on structures. Wind Actions  
 NHBC Standards: Chapter 7.2 Pitched Roofs

**GDRH-CL System Components**

**6 Metre Vent Roll**

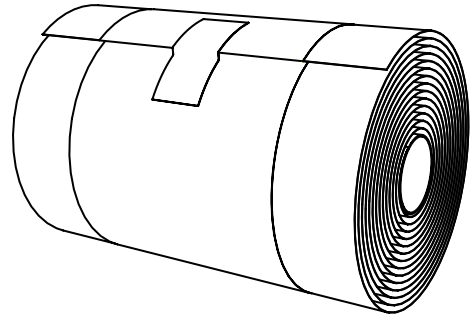

**Clay Ridge Union**

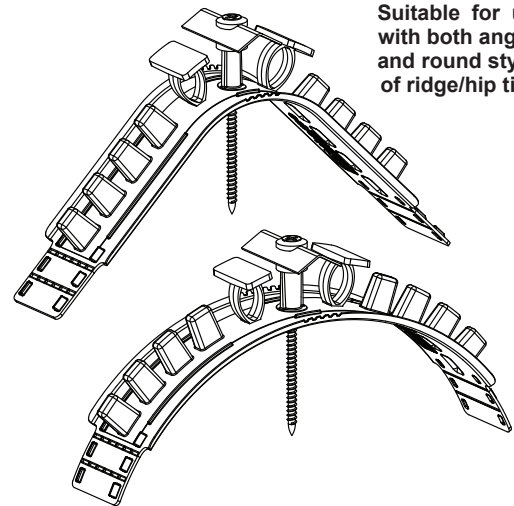

Suitable for use with both angled and round styles of ridge/hip tiles

**Hip Support Tray**

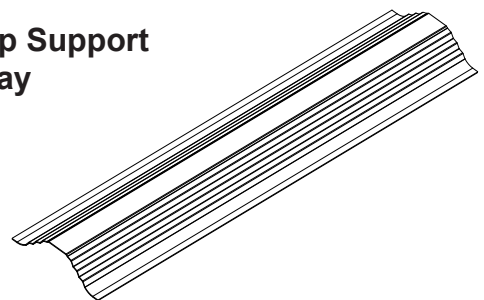

**GDRH-CL System Pack Quantities**

<b>GDRR-RR</b>	x1 6 metre Vent Roll
<b>GDRR-CU</b>	x13 Clay Ridge Unions
<b>GDRH-ST</b>	x6 1.1 metre long Hip Support Trays

MANTHORPE BUILDING PRODUCTS LTD  
 MANTHORPE HOUSE  
 BRITAIN DRIVE  
 CODNOR GATE BUSINESS PARK  
 RIPLEY  
 DERBYSHIRE DE5 3ND

TEL: 01773 514 200  
 FAX: 01773 514 262  
 EMAIL: bpsales@manthorpe.co.uk  
 WEB www.manthorpe.co.uk

DRN B.H. Date 30.01.17

The company maintains a policy of continuous development of its product range and reserves the right to amend the specification without notice.

DRG No

**MBP 8323**

Issue

**A**