

### Roll-Out Dry Ridge System - Ridge Union

CODE **GDRR-RU**

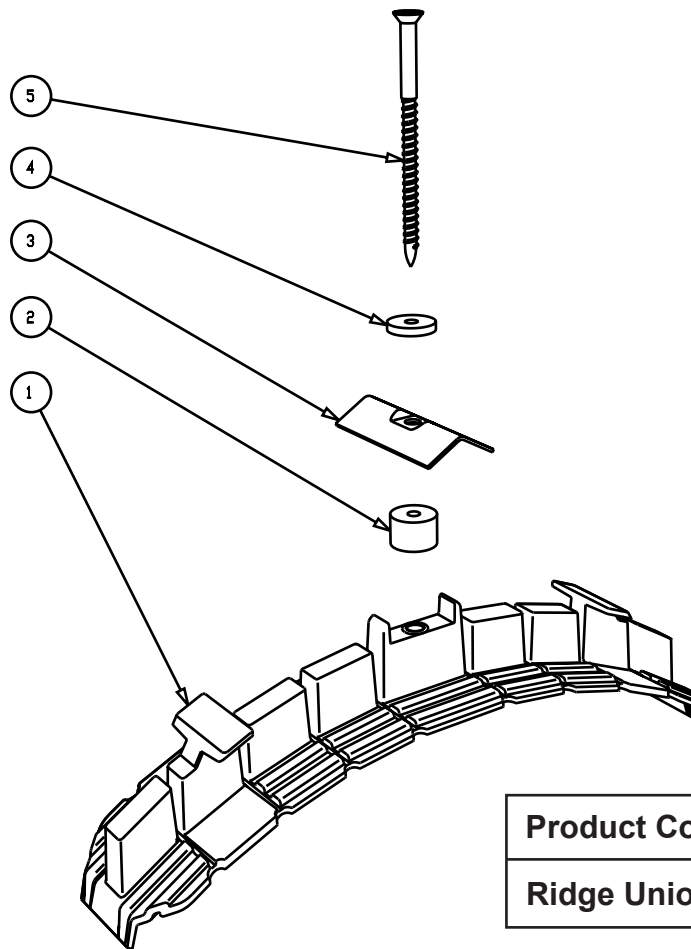

**Product Codes:**

**Ridge Union**

**GDRR-RU**

#### Description

The Ridge Union is made up of an assembly of parts, as shown in the diagram. The parts are as follows:

1. Ridge Union Body, injection moulded in UV stabilised polypropylene
2. Foam Washer, made from expanded polyethylene
3. Clamp, made from 304 grade stainless steel
4. Neoprene Rubber Washer
5. Countersunk Screw, made from 304 grade stainless steel

The Ridge Union sits in the gaps between each of the ridge tiles, holding them in place. The Ridge Union Body slides onto the end of the ridge tile and is flexible so that it bends to the shape of the tile. The next ridge tile slots into the other side of the Ridge Union Body and this continues along the full length of the ridge.

Once the ridge tiles are all correctly rested in place, the Ridge Unions are secured by driving the Countersunk Screw, assembled with the Washers and Clamp, through the hole in the top and into the horizontal batten below.

The Countersunk Screws should be tightened down so that the Clamp presses down on the ridge tile securing it in position.

The Ridge Union forms part of Manthorpe's Dry Ridge System which can be purchased as a kit, with all the parts required to cover a run of approximately 6 metres.

MANTHORPE BUILDING PRODUCTS LTD  
 MANTHORPE HOUSE  
 BRITAIN DRIVE  
 CODNOR GATE BUSINESS PARK  
 RIPLEY  
 DERBYSHIRE DE5 3ND

TEL: 01773 514 200  
 FAX: 01773 514 262  
 EMAIL:  
 sales@manthorpe.co.uk  
 WEB  
 www.manthorpe.co.uk

DRN B.H. Date 02/04/08

The company maintains a policy of continuous development of its product range and reserves the right to amend the specification without notice.

DRG No  
**MBP 8266**  
 PAGE (1 OF 2)

Issue

**B**

### Roll-Out Dry Ridge System - Ridge Union

CODE **GDRR-RU**

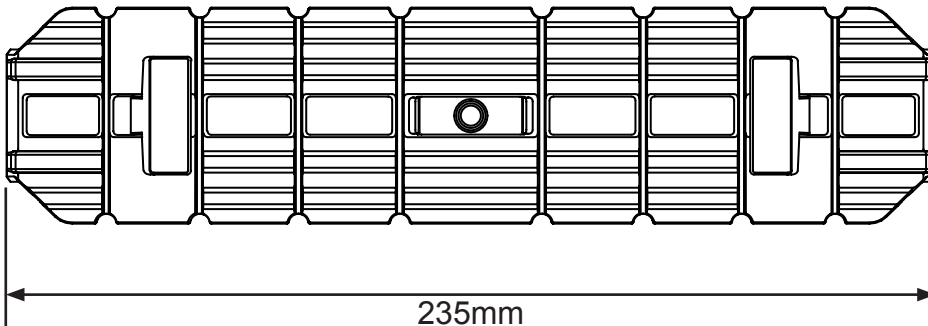
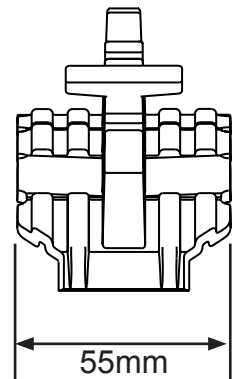
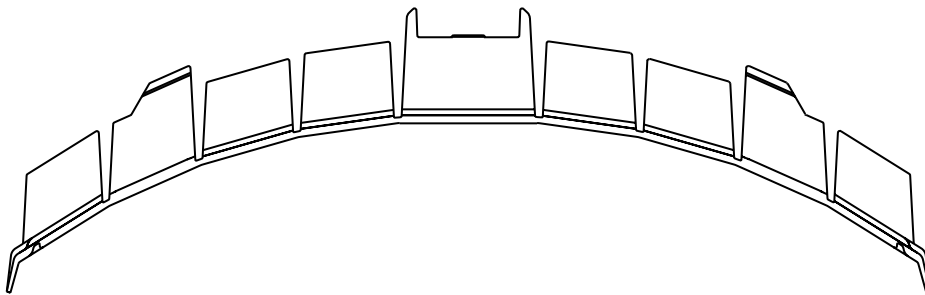

#### Fixing:

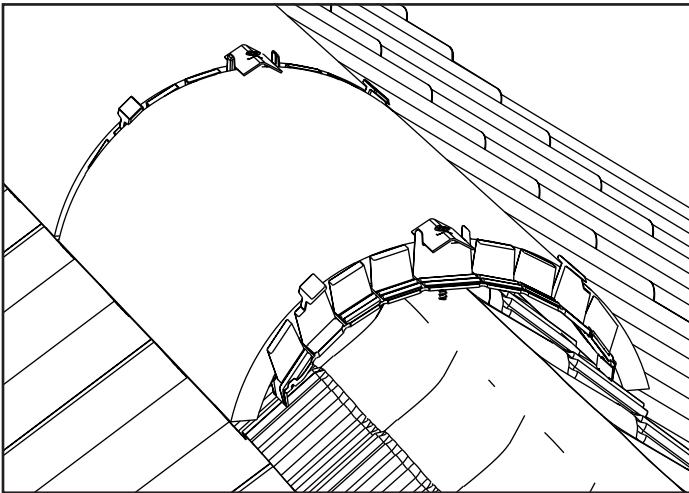

#### References

BSI: British Standard 5534:2003  
 BSI: British Standard 6399-2:1997  
 NHBC Standards Chapter 7.2

<b>Roof Pitch Compatability</b>	15° to 45° Pitch
<b>Weight</b>	0.066 kg each
<b>Packaging</b>	12 in a pack
<b>Materials</b>	UV Stabalised Polupropylene
<b>Manufacturing Process</b>	Injection moulded
<b>Colour Variations</b>	Black (BL) <span style="display: inline-block; width: 15px; height: 15px; background-color: black; vertical-align: middle;"></span>

MANTHORPE BUILDING PRODUCTS LTD  
 MANTHORPE HOUSE  
 BRITAIN DRIVE  
 CODNOR GATE BUSINESS PARK  
 RIPLEY  
 DERBYSHIRE DE5 3ND

TEL: 01773 514 200  
 FAX: 01773 514 262  
 EMAIL: sales@manthorpe.co.uk  
 WEB www.manthorpe.co.uk

DRN B.H.

Date 02/04/08

DRG No

Issue

The company maintains a policy of continuous development of its product range and reserves the right to amend the specification without notice.

**MBP 8266**  
 PAGE (2 OF 2)

**B**