

Product Data Sheet

Brett Martin Ltd. 24 Roughfort Road, Mallusk, Co. Antrim, N.Ireland, BT36 4RB
Technical Service Department: Phone +44 (0)28 9084 9999 Fax: +44 (0)28 9083 6666

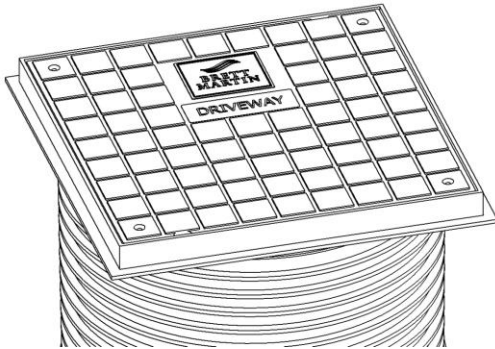

Brett Martin (SfA7) Adoptable Inspection Chamber System

315mm Diameter with 110mm Base

Description – The 315mm Brett Martin Adoptable Inspection Chamber System consists of a Base, Riser(s) and Riser Seal(s). It is used to connect drainage or sewerage installations and/or change the direction of drainage or sewerage runs and terminates at ground level. The termination at ground level permits the introduction of cleaning, inspection and test equipment and the removal of debris but does not provide access for personnel. It is certified to BS EN 13598-1 to satisfy the requirements of Clause 2.48 of the Building Regulations part H1 and the requirements of Sewers for Adoption (7th Edition).

Material – Polypropylene

Colour - Terracotta

Shaft Diameter – 315mm

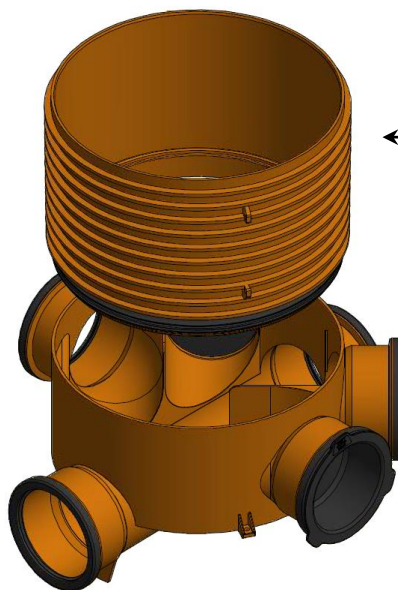

← Chamber riser complete with seal, 185mm invert
- Product code B3157

← Chamber base with 110mm connections, 190mm invert
- Product code B3156

Installation Tips

- Always chamfer cut pipe and lubricate all plain ended spigots for perfect joints
- Where external soil stacks are connected to the side inlet of a preformed chamber, ensure that the distance between the two is a minimum of 750mm to help prevent cross flow of solids onto the opposite benching.
- Always use the main channel of a chamber at a change of direction of the main run