

EasyLiner

Modular Inspection Chamber

Pennine Manufacturing LDT
Fold Mill, Bradley Lane, Bolton, BL2 6RR
T: 01204 361 547 F: 01204 380 872
Email: info@pennineindustries.com

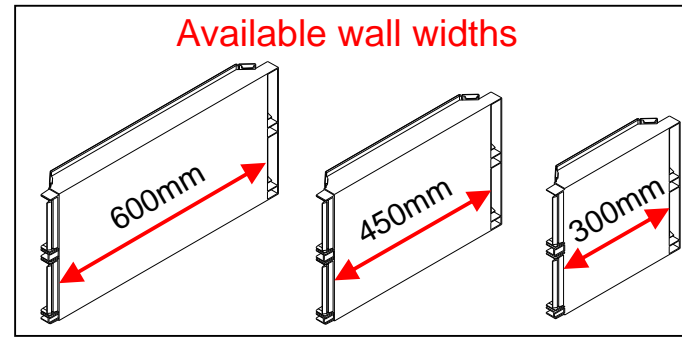

Knockouts

- Ø 63mm
- Ø 115mm
- Ø 185mm

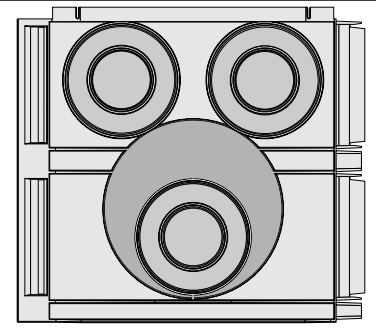

1

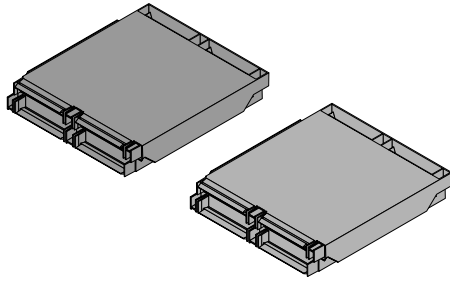

2

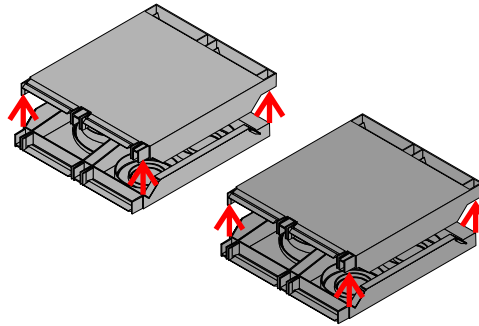

3

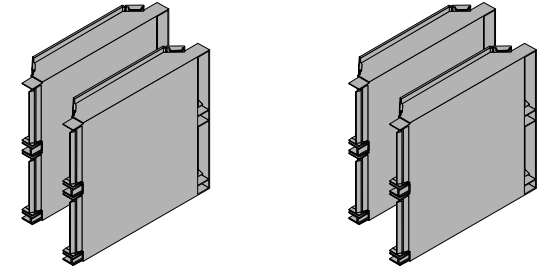

4

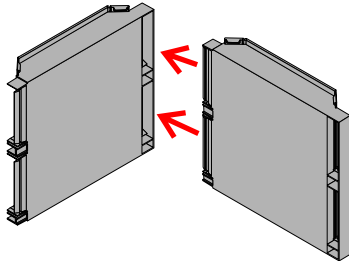

5

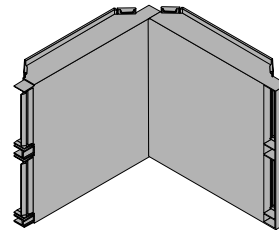

6

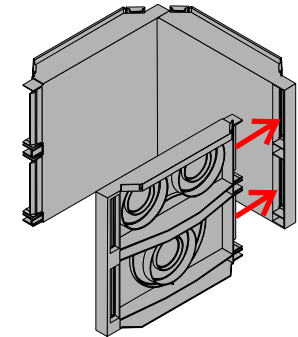

7

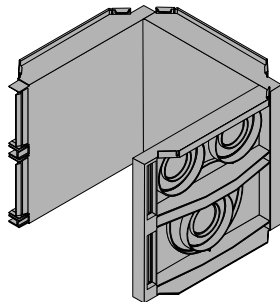

8

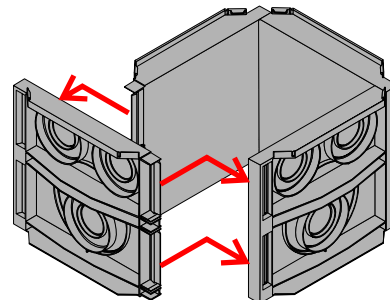

9

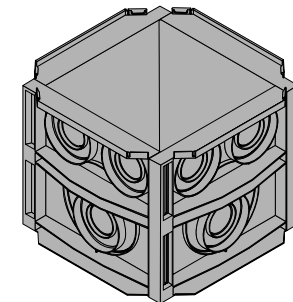

10

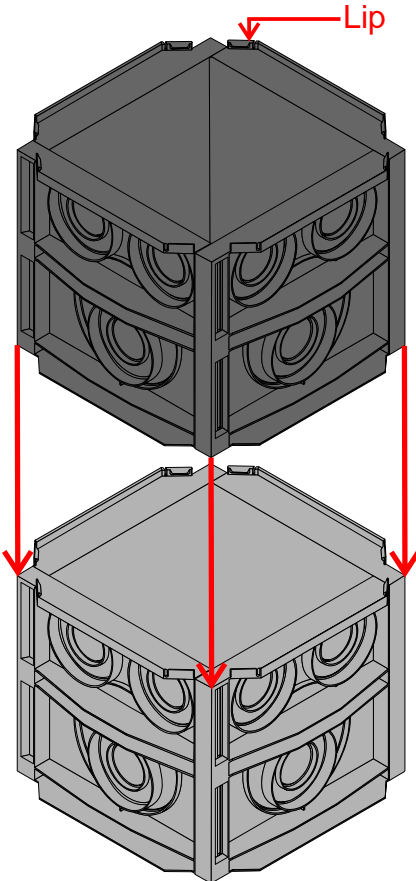

11

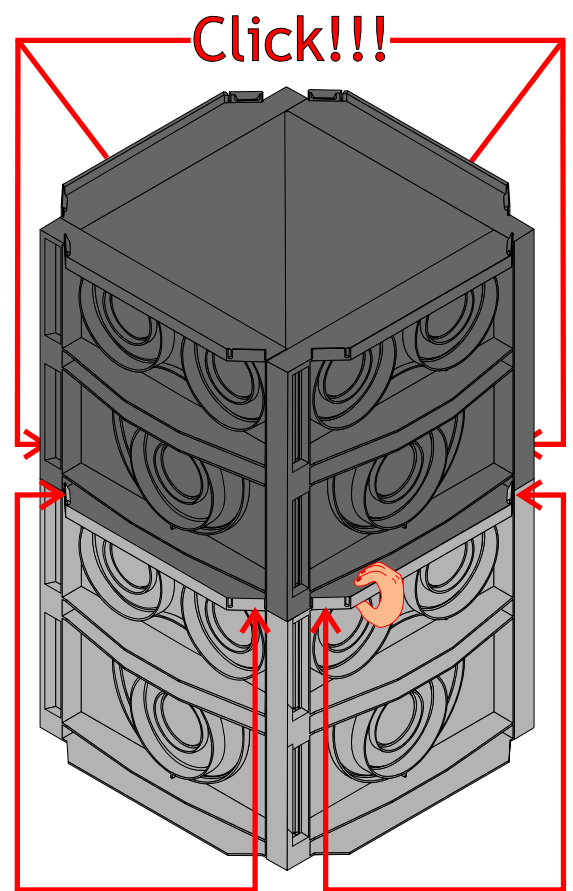
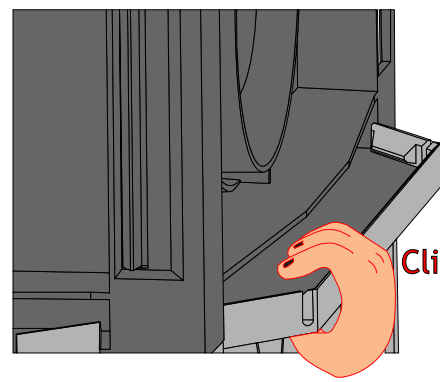
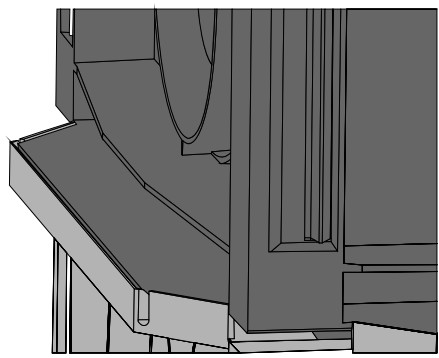

11

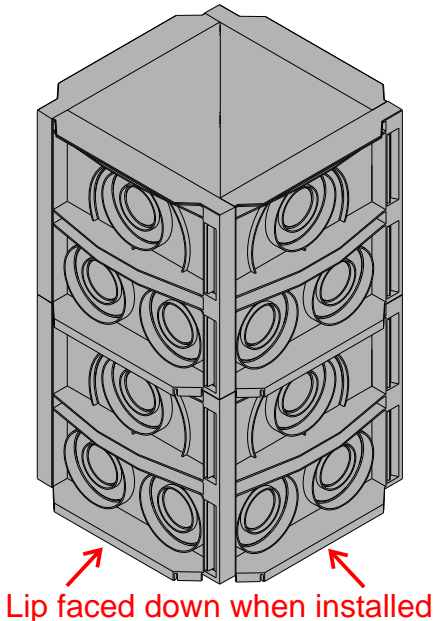

Installation Instructions

- 1) Assemble chamber with required number of rings (the flat end is up and the end with the lip is down)
- 2) Excavate hole to required depth allowing for the base and lid. Allow 50mm clearance on all 4 sides for concrete backfill.
- 3) Install the required base.
- 4) Make any required holes using knock-outs where possible (the larger knockouts need webs cutting) or core drill.
- 5) Fit the chamber into position and make any necessary pipe connection.
- 6) Backfill with concrete.
- 7) Fit manhole lid and frame and make good the surrounding area as required.
- 8) Leave 3 days for the concrete to harden before allowing loads to be applied.