

MEALINE S, G

Drainage channels including channel covers, passable for cars*

MEALINE S

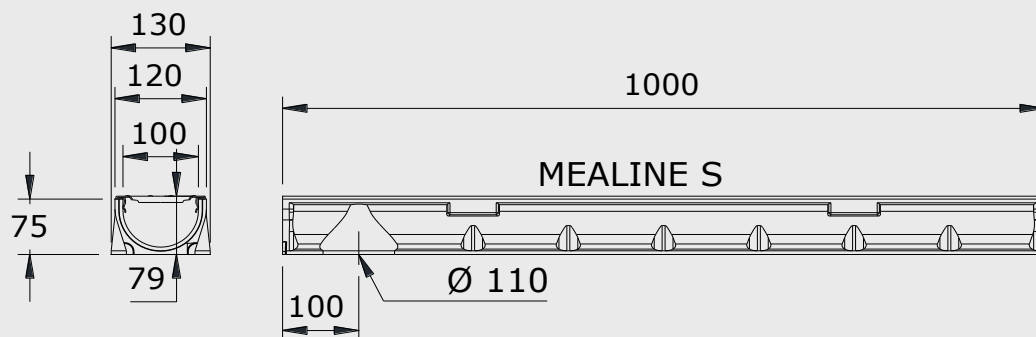

Material properties

Channel unit

- o Polymer concrete: based on polyester resin, with natural minerals
- o Compression resistance: $\geq 90 \text{ N/mm}^2$
- o Flexural tensile strength: $\geq 22 \text{ N/mm}^2$
- o Modules of elasticity: $25000 - 35000 \text{ N/mm}^2$
- o Density: $2,1 - 2,3 \text{ kg/dm}^3$
- o Linear expansion coefficient: approx. $1,45 \times 10^{-5} \text{ 1/K}$
- o Heat resistance: 100°C permanent exposure, short-term exposure (5 min.) to 200°C
- o Frost resistance: $- 50^\circ\text{C}$
- o Water penetration level: 0 mm
- o Water absorption: $< 0,05\%$
- o Material structure: capillary free

Channel covers

- o ductile iron
- o galvanized steel

Remark

* Channel cover loading class A15 to EN 1433.

Technical datasheet Drainage Systems

MEALINE

CW 100

passable for cars*

MEALINE S, G

Drainage channels including channel covers, passable for cars

Channel units made of polymer concrete including galvanized steel slotted grating* or ductile iron grating. Passable for cars*.

Clear width 100mm, total width 130mm, without fall.

MEALINE S - complete drainage system with galvanized steel slotted grating - snap channel cover securement*

material group	product description	length [mm]	total height [mm]	EDP-No. 010...	EAN-code 4001990...	kg/unit	units/pallet
DY	MEALINE S ¹⁾	1000	78	150763	231210	6,70	60

MEALINE G - complete drainage system with ductile iron grating - snap channel cover securement, class B125 to EN 1433

material group	product description	length [mm]	total height [mm]	EDP-No. 010...	EAN-code 4001990...	kg/unit	units/pallet
DY	MEALINE G ¹⁾	1000	81	150769	273401	9,30	60

1) Connection facility for vertical outlet Ø 110mm

MEALINE S, G accessories

MEALINE silt box

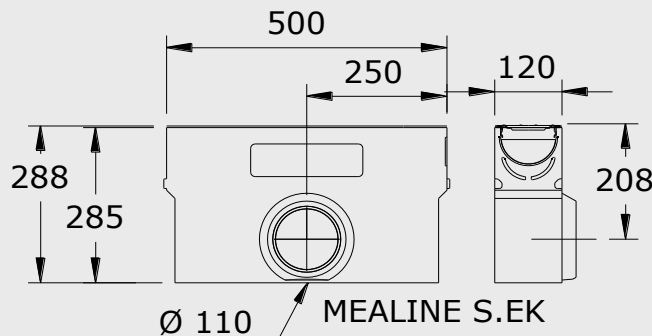

MEALINE - silt box made of polymer concrete incl. cover and sediment bucket

material group	product description	length [mm]	total height [mm]	EDP-No. 010...	EAN-code 4001990...	kg/unit	units/pallet
MD	MEALINE S.EK including galvanized steel slotted grating*	500	288	150779	231593	13,30	1
MD	MEALINE G.EK including ductile iron grating class B125	500	291	150771	273418	14,00	1

Remark

* Channel cover loading class A15 to EN 1433.

Technical datasheet Drainage Systems

MEALINE

CW 100

passable for cars*

MEALINE S, G accessories

MEALINE corner connection

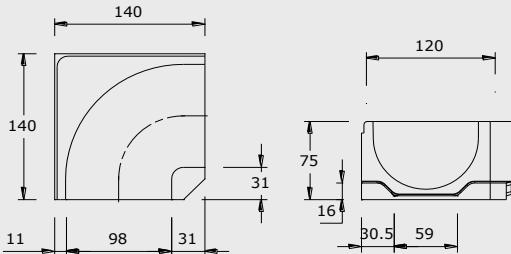

MEALINE cover for corner connection

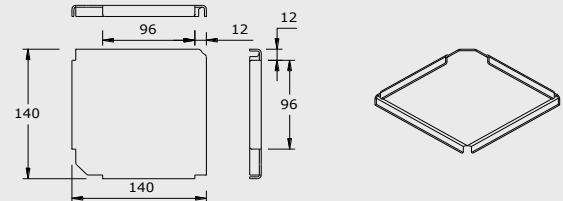

MEALINE - corner connection for connection of two MEALINE channels in 90° angle

material group	product description	length [mm]	total height [mm]	EDP- No. 010...	EAN- code 4001990...	kg/unit	units/ pallet
MG	MEALINE S, G corner connection made of polymer concrete including agglutinated galvanized steel cover	140	77	150172	275061	1,85	1

MEALINE accessories

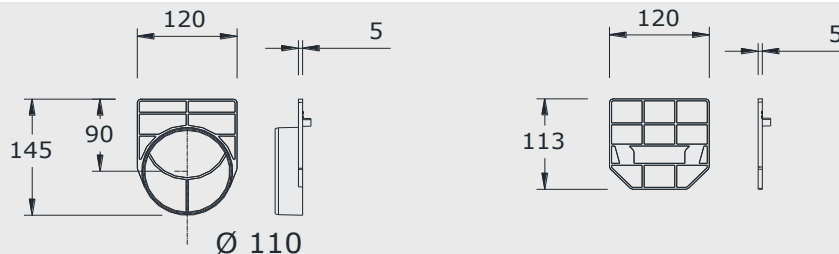

MEALINE - accessory sets and end caps

material group	product description	material	EDP No. 010...	EAN- code 4001990...	kg/unit	units/ pallet
MD	Outlet set with connector Ø 110mm, sediment bucket and roadable foul air trap	PP	150730	027677	0,20	1
MD	Outlet set with connector Ø 110mm, and 2 end caps for channel start and end	PP	150199	274774	0,22	10
MD	Outlet connector Ø 110mm, with preformed bearing ring for installation of roadable foul air trap 010145060	PP	150197	274767	0,08	10
MD	Roadable foul air trap including dirt strainer	PP	145060	024874	0,09	1
MD	End cap for channel start and end	PP	150191	267530	0,10	20
MD	End cap for channel end with connector Ø 110mm	PP	150195	267547	0,10	10

MEA Water Management GmbH
 Sudetenstraße 1
 86551 Aichach
 Tel.: +49 (0) 82 51. 91 0
 Fax: +49 (0) 82 51. 91 13 00
 E-Mail: info.drainage@mea.de
 www.mea-group.com

Remark

* Channel cover loading class A15 to EN 1433.