

Acoustic Deck 34

PREMIUM OVERLAY BOARD

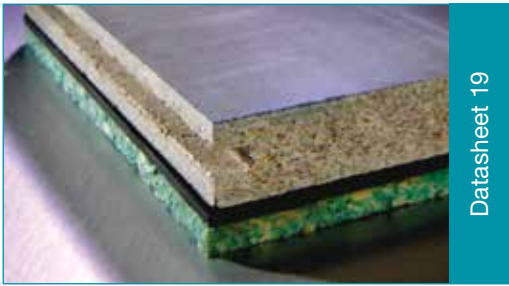

Datasheet 19

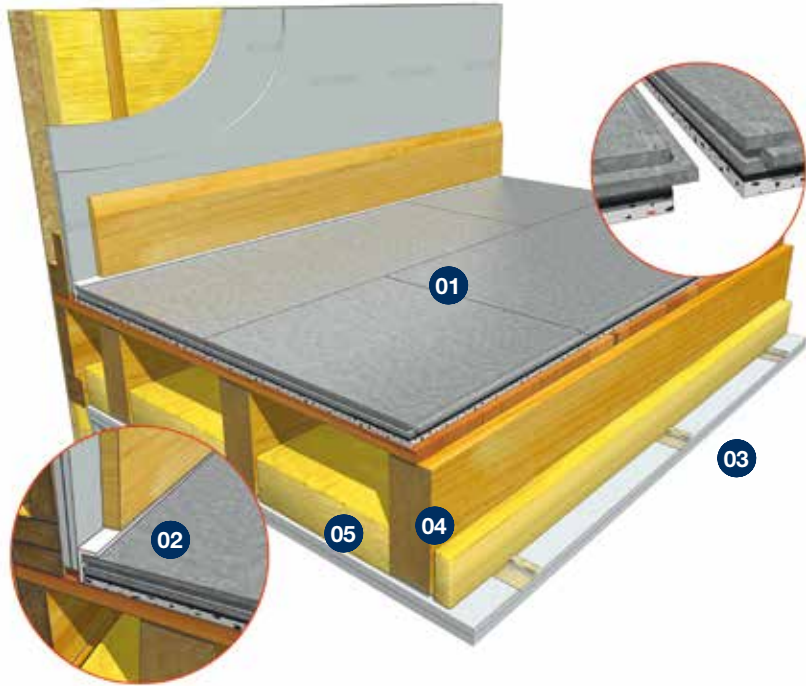

- 01 JCW Acoustic Deck 34
- 02 JCW L Shaped or Flat Perimeter Edging Strip detail
- 03 Resilient Bars and 2 layers x 15mm Acoustic Plasterboard
- 04 225mm depth Timber Joists
- 05 100mm x 45kgs/m³ Mineral Wool Slab

Product Code: Deck 34: 1079	
Deck 34: Premium Overlay board	
Acoustic Floating Floor: Deck 34: 22mm t&g Cement Based Board with a pre-bonded 12mm high performance resilient layer	
<p>Refurbishment</p> <ul style="list-style-type: none"> • Ideal for both general and new domestic separating floor upgrades in lofts and extensions etc • Enhanced airborne sound reduction achieved via mass board weight, high performance barrier mat and foam pre-bonded Impact layer • Ideal decking for tiling, floated wood, laminate, carpets/carpet tiles. Additional floor preparation may be required for vinyl overlays 	<p>PCT/PT</p> <ul style="list-style-type: none"> • Superior performance system for both Conversion & New Build projects • It is essential recommended components shown above are used and correctly installed/detailed to meet the requirements where Pre-completion Sound Testing is required
Sheet Size: Deck 34: 34mm x 600mm x 1200mm (0.72m ²) Weight: 23 kgs	
UKAS laboratory test data based on Deck 34 overlaid onto decking Deck 34 Impact: 49 dB Lnt,w Airborne: 57 dB Rw + Ctr,	
<p>Method of Compliance</p> <p>PCT/PT (Scotland)</p>	<p>Ancillary Products</p> <p>1130 JCW Flat Edging Strip (50 Lm x 150mm x 5mm) 1170 JCW Universal L Shaped Strip (2 Lm x 53mm x 23mm) 1196 JCW Waterproof PVA Adhesive (1 Litre) 1027 JCW Acoustic Sealant (310ml)</p>

Domestic Dwellings | Offices | Hotels | Conference Centres | Leisure Centres | Schools | Restaurants | Showrooms



Unit 32-34 Waters Meeting Development
Britannia Way, Bolton, BL2 2HH

Sales helpline **01204 548400**
8.30am - 5.00pm Monday to Friday

sales@acoustic-supplies.com
www.acoustic-supplies.com

Deck 34 Cement Particle Board Processing

Machining

Particle Board is machined and processed in the same manner as resin bonded particle boards, but ensure that tungsten carbide tipped blades are used at all times. Comprehensive tests have shown that wear on tools during the processing of Particle Board is significantly lower when compared with resin bonded board. This is due to the lack of resinification and a lower degree of heating.

Cutting/Sawing

Equipment

- Cross cut hand saws for thicknesses up to 12mm
- Jigsaw for thicknesses up to 12mm and small work
- Portable circular saw
- Fixed saw for dimensioning (vertical or horizontal)

Type of blade

- Alternative or trapezoidal teeth
- Chart shows number of revolutions and number of teeth (Z)

Diameter mm	250	300	350	400
Panel Thickness up to 12mm	Z=48	Z=60	Z=72	Z=72
Panel Thickness exceeding 12mm	Z=36	Z=48	Z=54	Z=60
Number of Revolutions rpm	3000/4500	3000	3000	3000/1500

Milling

Common machines with carbide-tipped tools. The higher the rpm, the better the milled edge.

Counter-Sinking Drilling

Particle Board can be drilled using conventional portable drilling machines; high speed steel drills or tungsten carbide drills (for prolonged use) and central tip for precision drilling. Although particle board is a wood and cement panel it is not concrete and therefore does not require percussion drilling. The drilling speeds are the same as for chip-board panels (3000/4000 rpm).

Sanding

Particle Board can be sanded using a vibrating sanding machine or belt sanding machine. Belts should be 40-80 grains; open coat structure with linear speed of 20 to 28 m/sec. When working in confined areas dust extraction equipment is recommended.

Sanding

Hand-held Orbital Sander, Hand-held Belt Sander. When used indoors, use vacuum dust extractor.

Basic guidance notes for installation of JCW Acoustic Decking 19, 28, 32, 33, 34, 37, 37c

JCW Acoustic Decking floor panels are supplied in 2 standard board sizes dependant on the material. 1) T&G Chipboard 2400mm x 600mm. 2) T&G Cement Board 1200 x 600 & T&G MDF 1200 x 600mm. All acoustic panels are laid as a floating floor (i.e. no mechanical fixings). The boards must be dry and acclimatised at least 24 hours prior to installation, this will minimise any expansion or contraction after installation.

The substrate or joists should be flat, dry, and free from all debris. Acoustic boards are best laid towards the end of the project to protect from general trades, high floor loadings and moisture leading to expansion.

- The floor area/s to be overlaid should be carefully planned prior to commencing installation to minimise wastage. There are two overlay board types; **1) Non-Structural** onto an existing sub-floor. **2) Structural** for Direct to Joist. The boards must be laid on to flat or levelled joists in the opposite direction of the joists. Direct to Joist boards can also be laid onto an existing sub-floor.
- Ensure that the wall surfaces are prepared (plaster skimmed or plaster boarded down to the level of the sub-deck). Any gaps will facilitate the unwanted transmission of sound via the wall edges.
- Apply 5mm foam flat wall **JCW Perimeter Edging Strip or L shaped strips** to the base of all perimeter walls allowing approximately 15mm excess foam above the finished acoustic board height, this can later be folded down on top of the acoustic floor surface to isolate the skirting boards. Any unwanted excess foam can then be cut back with a sharp knife.
- Remove any tongues at the wall edges, then cut & scribe the first corner board into place and butt up to (do not compress the JCW Perimeter Edging Strip) the Edging Strip. All T&G board joints must be fully adhesive bonded using our recommended adhesive. The last board in the first row should be cut to length and the off-cut carried forward to begin the second row.
- Proceed with the second and successive rows ensuring that all board joints are staggered. The last row of boards will require accurate cutting & scribing to butt up to the wall. Any minor gaps between the **JCW Perimeter Edging Strip** and the acoustic board must be filled with JCW Acoustic Sealant/Mastic. It is imperative that the JCW Perimeter Edging Strip is not compressed in order to maintain acoustic isolation and an allowance for expansion.
- At doorways; the acoustic floor should not be continuous with adjoining areas. At the door threshold leave a 5mm gap between the adjoining acoustic boards and fill with JCW Acoustic Sealant. This action will ensure that the acoustic integrity is maintained within the room that is being Sound Tested. Note; if the sub-floor at the doorways is not flat, the acoustic boards may require additional base support to reduce compressive joint movement. Additionally the surface joints could be sanded up to 5mm to level if required.
- The finished floor should not be walked on for a period of up to 24 hours to allow the adhesive to cure undisturbed. NOTE; PVA adhesive will not cure in temperatures below 5° Celsius. Ensure that the board joint adhesive has fully cured prior to overlaying any final floor covering.

Any penetrations through the acoustic floor and beneath the separating ceiling must be correctly detailed and dealt with on a site by site basis.

Further assistance is available via our Technical Helpline.

Guidance for using Resilient Bars

Screw fix the pre-drilled section of the resilient bars at 400mm centres and perpendicular to the joists, battens or studs.

Screw fix acoustic plasterboards to the flat underside of the resilient bars, allowing a clearance of 100mm of the supporting timbers.

It is imperative that no screws penetrate through the resilient bar and into the supporting structure.

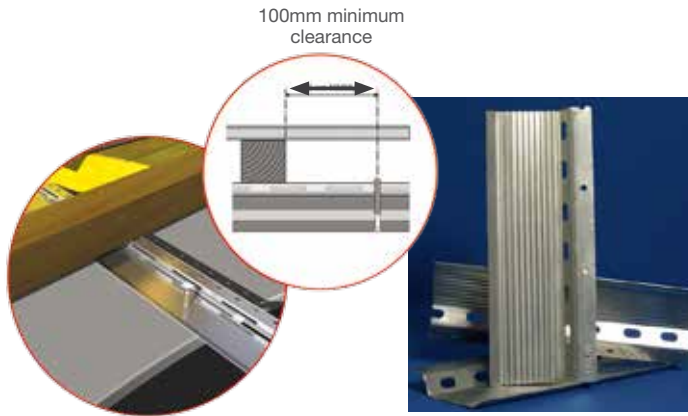

Disclaimer: The product and installation information contained in this Data Sheet and General Installation Guide is to the best of our knowledge correct. Please contact us direct, prior to starting works, for the latest information to enable confirmation of the specification.

Domestic Dwellings | Offices | Hotels | Conference Centres | Leisure Centres | Schools | Restaurants | Showrooms



Unit 32-34 Waters Meeting Development
Britannia Way, Bolton, BL2 2HH

Sales helpline **01204 548400**
8.30am - 5.00pm Monday to Friday

sales@acoustic-supplies.com
www.acoustic-supplies.com