

Acoustic Impactalay Plus

PREMIUM RESILIENT OVERLAY MATTING

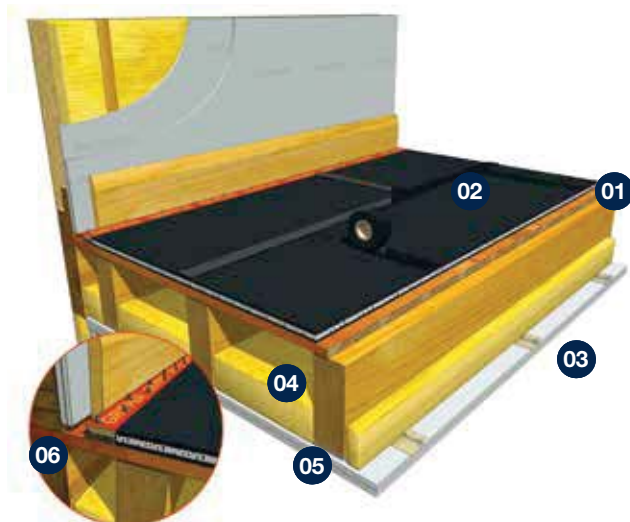

Datasheet 10.1



- 01** Existing Subfloor
- 02** JCW Impactalay Plus
- 03** Resilient Bars and 2 layers x 15mm Acoustic Plasterboard
- 04** 100mm 10/36kg/m³ Mineral Wool Quilt or 45kg/m³ Mineral Wool Slab
- 05** 225mm depth Timber Joists (Solid/Ijoists)
- 06** JCW Impactalay Plus Gripper Strip Detail

Product Code: Impactalay Plus (15mm) 1155

Premium Overlay Matting System for timber and concrete floors

Impactalay Plus: two acoustic layers of barrier mat with a resilient chip foam core

Refurbishment

- Ideal domestic Impact and Airborne sound insulation product where height is restricted
- Easily cut, trimmed and shaped for fast installation
- Impactalay Matting can be loose laid with taped joints and fully bonded to the sub-floor. Carpets and Engineered Wood floor overlays can be laid directly on top (ask for details). Gripper Edging Strips are required with carpet installations to raise and support the carpet gripper strips
- Due to the resilient nature of Impactalay Plus, thin Wood Laminates will require a minimum TG4 9mm MDF when installing bonded carpet, carpet tiles, vinyl & rubber flooring to reduce point loading & joint creasing
- See data sheet for further guidance

PCT/PT

- 15mm Impactalay Plus overlay system could be considered for Conversion projects based on the above structure
- It is essential the recommended components shown above are correctly installed and detailed when Pre-completion Sound Testing is required
- For further advice, please refer to individual product installation recommendations.

Sheet Size: Impactalay Plus: 15mm x 600mm x 1200mm (0.72 m²) **Weight m²:** 15.27 kgs/m² **Sheet Weight:** 10.80 kgs

UKAS accredited laboratory test data for the Floor Construction above:

Impactalay Plus (15mm): Impact: 39 dB Ln,w **Airborne Rw + Ctr:** 51 dB Rw + Ctr

Method of Compliance

PCT/PT (Scotland)

Ancillary Products

1140 JCW Impactalay Plus Gripper Strip
1034 JCW Black Cloth Jointing Tape
1022 JCW Impacta Adhesive

1127 JCW MDF
1196 JCW PVA
1089 JCW Contact Adhesive

Domestic Dwellings | Offices | Hotels | Conference Centres | Leisure Centres | Schools | Restaurants | Showrooms



Unit 32-34 Waters Meeting Development
Britannia Way, Bolton, BL2 2HH

Sales helpline **01204 548400**
8.30am - 5.00pm Monday to Friday

sales@acoustic-supplies.com
www.acoustic-supplies.com

JCW Impactalay Plus Installation Guide

JCW Impactalay Plus mats are easy to trim & fit.

For best results the matting should be laid onto a smooth flat sub-floor. Sub-floor preparation is important to ensure that the final decorative floor finish is adequately supported and meets with your expectations. If Timber sub-floors are undulating then it may be necessary to overlay with a minimum of 6mm ply wood. Concrete sub-floors may require partial screed levelling.

Carpet & Gripper: JCW Impactalay Plus can also act as a carpet underlay and is more than adequate for the vast majority of broadloom carpets. Prior to laying the acoustic matting, Butt the 9mm x 30mm x 1000mm JCW Gripper Strips up to the wall edges or skirting boards. Place the carpet gripper rods on top and up to the front edge of the JCW Gripper Strips then secure to the sub-floor using minimum 30mm pins; this should leave a small 5-8mm gap between the wall/skirting and gripper rod for the carpet to recess into. Laying the Mats; Butt joint the JCW Impactalay Plus mats up to the gripper rods and complete the floor area ensuring all mats are staggered row by row. The mats can be loose laid; however we suggest that the joints are secured using JCW Black Cloth Jointing Tape to reduce the possibility of curling and potentially showing through the carpet. Alternatively, JCW Impactalay Plus mats can be fully bonded to most sub-floors using JCW Impacta Adhesive.

Floated engineered wood planks with interlocking or bonded T&G joints: 14mm thickness and above can be floated & laid directly on top of JCW Impactalay Plus mats. All board joints should overlap the mat joints by at least 100mm.

Thin wood laminate: Thin laminate will generally require additional support to prevent the joints from dipping and snapping. We suggest adhesive bonding on top of the matting; a minimum overlay of 9mm TG4 and MDF board. (T&G joints to be bonded with PVA adhesive).

Bonded carpet/tiles: will require additional support to prevent the joints dipping & creasing the soft floorcovering. We suggest adhesive bonding on top of the matting; a minimum overlay of 9mm TG4 and MDF board. (T&G joints to be bonded with PVA adhesive).

Thin bonded vinyl, rubber, lino sheet & tiles: will require additional support to prevent any joint movement & dipping that may result in the material creasing at the joints. We suggest adhesive bonding; a minimum 9mm TG4 MDF boards on top of the matting. Some additional sanding & joint preparation may still be required to provide a suitable smooth surface. Note; Check first with high specification flooring manufacturers as to the minimum acceptable overlay type.

Ceramic & stone tiling: NOT recommended due to the compressive nature of JCW Impactalay and Impactalay Plus. Please contact us regarding alternative products in our range for tiling onto.

Adhesive bonding: in most situations JCW Impacta Adhesive (data sheet available on request) can be used to bond the materials described above. Where an instant bond or high grab adhesive is required we suggest using a 'Contact Adhesive.' In conservatories and highly glazed areas a specialist heat resistant adhesive will be required. We suggest that you contact Bostik or a reputable adhesive manufacturer for further advice.

Disclaimer: The product and installation information contained in this Data Sheet and General Installation Guide is to the best of our knowledge correct. Please contact us direct, prior to starting works, for the latest information to enable confirmation of the specification.

Kitchen, bathroom and toilets: Must be mechanically fixed to the subfloor. WC & Sink Pedestal – a 15mm plywood/MDF plinth should be mounted to the subfloor and must cover the footprint of the item.

JCW Impactalay Plus to be butted up to the plywood/MDF therefore maintaining a consistent floor level.

Fixed cupboards/wardrobes: Install JCW Impactalay Plus inside the cupboard/wardrobe to prevent flanking by airborne sound.

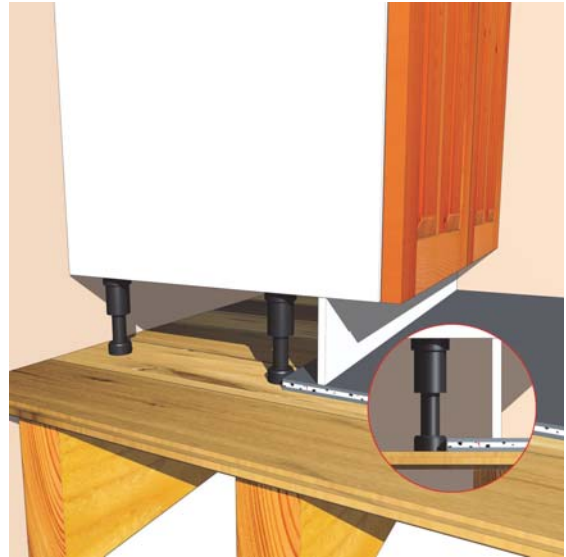

Stairs: The JCW impactalay plus sheets should be cut to the appropriate sizes before installation. JCW Impactalay plus should be bonded to the tread of the stair and, if airborne reduction is required then also bonded to the riser using JCW Impacta Adhesive.

The JCW Impactalay plus must be installed alongside rubber JCW Perimeter Strips. The timber gripper strips are to be nailed through the rubber JCW Perimeter strips and into the tread and/or riser using minimum 30mm nails as described in the diagram.

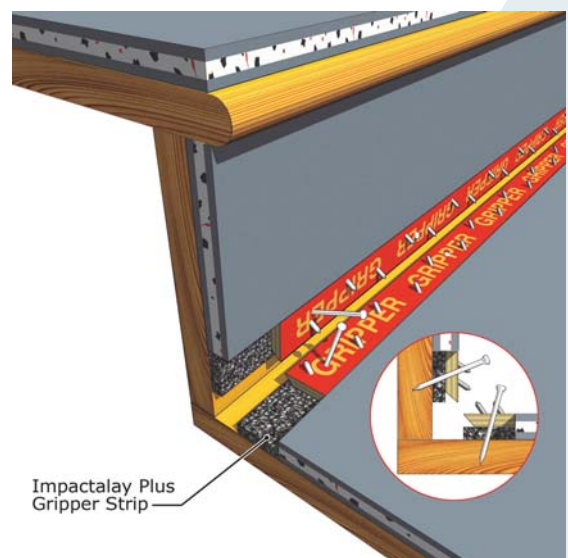

Impactalay Plus Gripper Strip

Domestic Dwellings | Offices | Hotels | Conference Centres | Leisure Centres | Schools | Restaurants | Showrooms



Unit 32-34 Waters Meeting Development
Britannia Way, Bolton, BL2 2HH

Sales helpline **01204 548400**
8.30am - 5.00pm Monday to Friday

sales@acoustic-supplies.com
www.acoustic-supplies.com