

**ROCKWOOL®**

**FIREPRO®**

Intumescent Expansion Joint Seal

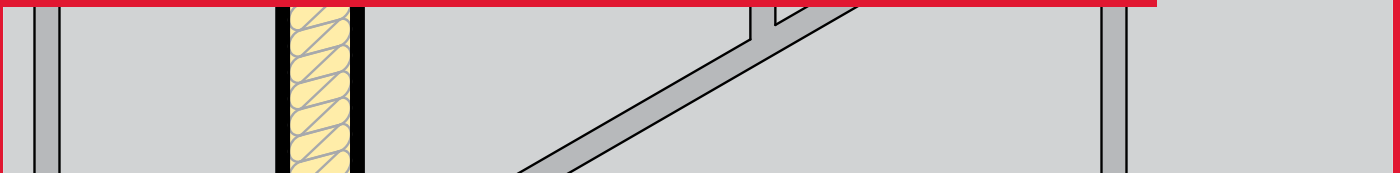

## Firestop solution for linear joints in walls & floors

Intumescent Expansion Joint Seal provides an easy retro-fit solution to firestop existing construction joints up to 75mm thick in floors and walls.



# Intumescent Expansion Joint Seal

## Description

Intumescent Expansion Joint Seal is a compressible strip formed by shrink wrapping a graphite based intumescent polymer to both faces of a ROCKWOOL core.

Intumescent Expansion Joint Seal is supplied in one metre lengths to suit the joint to be filled. The width of the product is dependent on the fire rating required (see Table 1 and 2).

The seal is installed by simply compressing by hand and then pushing into the joint. Adjacent pieces of the product are tightly butted together. There is no need to use any adhesives or intumescent sealant in conjunction with the product.

In a fire, the graphite based intumescent material swells to form a hard char, which prevents the passage of fire and smoke through the joint.

Intumescent Expansion Joint is suitable for use in:

- Blockwork cavities
- Curtain wall/Concrete slab interfaces
- Expansion joints
- Structural joints

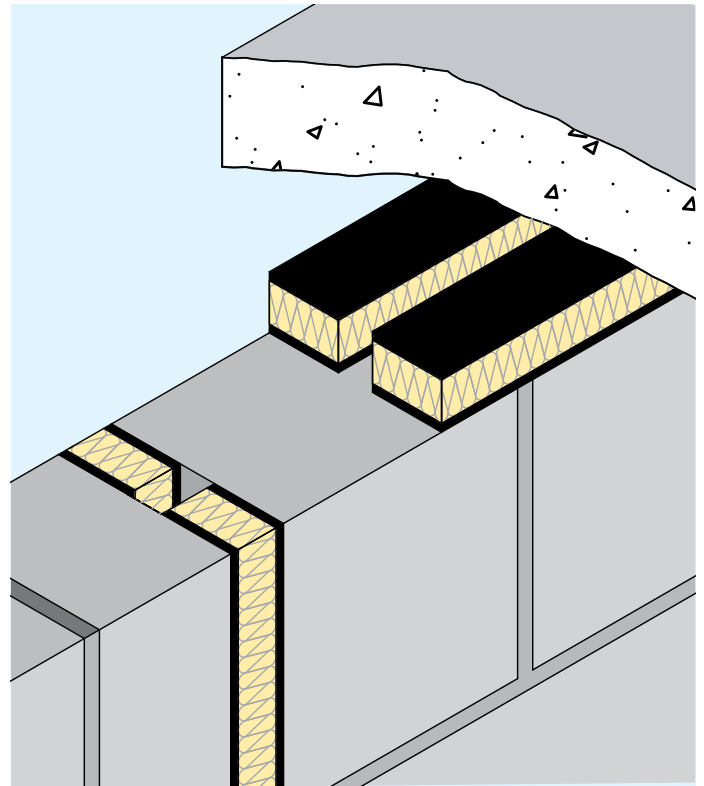

Figure 1

## General benefits:

- Simple to install
- Water resistant
- Maintenance free
- Available in small quantities
- Available from 48 hours of order

# Intumescent Expansion Joint Seal

Intumescent Expansion Joint being a component of structure satisfies both integrity and insulation requirements as shown in the table above.

## Specification

Install Intumescent Expansion Joint to provide up to 4 hours fire rating to all construction joints up to 75mm thick. Installation to be fully in accordance with manufacturer's instructions.

## Installation instructions

Intumescent Expansion Joint is used to prevent fire penetration through movement joints and gaps in walls and concrete floors for a specified period up to 4 hours. They are manufactured oversize to fit under compression.

- 1) Remove all loose debris and compound from the gap
- 2) Ensure correct width is installed to suit the required Fire Rating
- 3) Where the gap varies in the length to be sealed, ensure that the correct thickness is installed under compression
- 4) Do NOT remove sleeving
- 5) Keep material dry and protect from impact damage
- 6) Compress and insert the strip into the gap ensuring tight butt joints

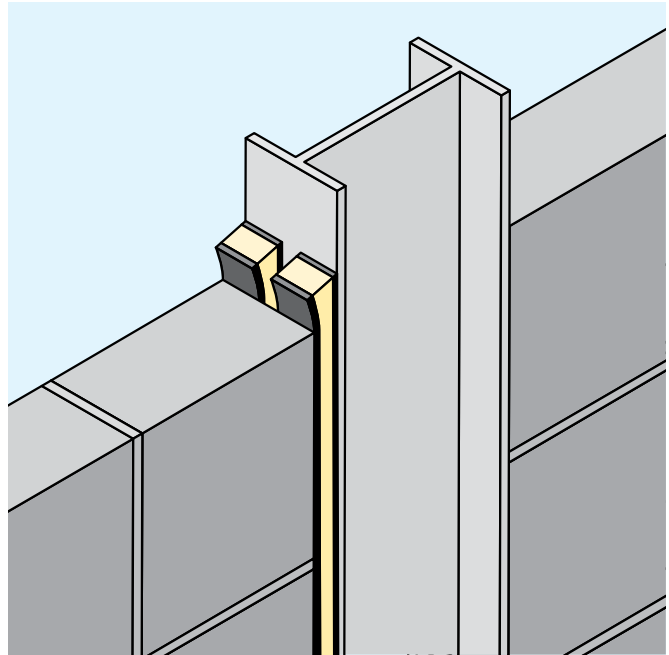

Building Regulations 2013 – Approved Document B – B2/3/4 – Internal fire spread (structure), paragraphs 0.10 – 0.11, state that the spread of fire inside a building can be restricted, by provisions for elements of structure to have a specified minimum period of fire resistance. Fire resistance is defined in terms of both integrity and insulation requirements when applied to fire separating elements.

**Table 1 - Fire resistance (FR) performance**

Joint Size	Width of Seal	Fire Rating (Integrity/Insulation)	Single / Double Seal
Up to 10mm	25mm	2 Hours	Single
	50mm	4 Hours	Single
Joints from 11mm up to 50mm	25mm	2 Hours	Dual
	50mm	4 Hours	Dual
Joints from 51mm up to 75mm	25mm	2 Hours	Dual
	50mm	4 Hours	Dual

Please note that seals for joints up to 50mm wide must be fitted under a minimum of 5mm compression and joints 51-75mm must be fitted under a minimum of 10mm compression.

ROCKWOOL Limited  
Pencoed  
Bridgend  
CF35 6NY

info@rockwool.co.uk  
www.rockwool.co.uk

**ROCKWOOL®**

ROCKWOOL Limited reserves the right to alter or amend the specification of products without notice as our policy is one of constant improvement. The information contained in this data sheet is believed to be correct at the date of publication.

Whilst ROCKWOOL will endeavour to keep its publications up to date, readers

will appreciate that between publications there may be pertinent changes in the law, or other developments affecting the accuracy of the information contained in this data sheet.

The above applications do not necessarily represent an exhaustive list of applications for Intumescent Expansion Joint Seal. ROCKWOOL Limited does not accept

responsibility for the consequences of using Intumescent Expansion Joint Seal in applications different from those described within this data sheet. Expert advice should be sought where such different applications are contemplated, or where the extent of any listed application is in doubt.

CREATE AND PROTECT®